

# **SEDIMENTATION IN STREAM NETWORKS (HEC-6T)**

## **User Manual**

**January 3, 2002**

**A Generalized Computer Program  
of  
MBH Software, Inc.**

## **Copyright**

**Copyright ©2002 by MBH Software, Inc. All rights reserved worldwide.**

***This manual is part of the HEC-6T documentation. The contents of this manual and the associated HEC-6T software are the property of MBH Software, Inc. and are copyrighted. Any reproduction in whole or in part is strictly prohibited without written permission from MBH Software, Inc. Second Printing.***

## **Disclaimer**

***MBH Software, Inc. reserves the right to revise it's software and publications with no obligation to notify any person or any organization of such revision. In no event shall MBH Software, Inc. be liable for any loss of profit or any other commercial damage, including but not limited to special, consequential, or other damages.***

## **Distribution Policy**

***This software is licensed, not sold. Regardless of the method of marketing, HEC-6T is not in the public domain. It is copyrighted by MBH Software, Inc.***

**MBH Software, Inc.  
465 East Northside Drive  
P.O. Box 264  
Clinton, MS 39060-0264**

**(601)925-4092  
FAX: (601)925-4093  
mbh2o@aol.com**

## Table of Contents

1. INTRODUCTION .....	1-1
Purpose and Scope .....	1-1
Instructions for Installing HEC-6T .....	1-1
Distribution disk .....	1-1
Install HEC-6T .....	1-1
Instructions for Executing HEC-6T .....	1-1
General Description. ....	1-1
Files. ....	1-1
Output .....	1-2
Print-out .....	1-2
Graphics .....	1-2
TAPE12 .....	1-2
Input Data .....	1-2
Data Edit .....	1-3
2. GEOMETRIC MODEL .....	2-1
Introduction .....	2-1
The Stream Network .....	2-1
Branches and Control Points .....	2-2
Junction Control Points .....	2-2
Distributary Control Point .....	2-2
Island Flow .....	2-2
Cross Sections and Reach Lengths .....	2-2
Data Sequence .....	2-2
Direction of Flows .....	2-2
Local Inflows/Outflows .....	2-3
Control Points .....	2-3
Boundary condition control points .....	2-3
Junction control points .....	2-3
Internal operating rules (X5-Records) .....	2-3
Deposition and Erosion Limits .....	2-4
Coding Bridge Cross Sections .....	2-7
Cross Section Layout .....	2-7
Coding Bridge Cross Sections .....	2-8
No Special Bridge Routine .....	2-8
3. SEDIMENTARY MODEL .....	3-1
Introduction .....	3-1
User Supplied Sediment Transport Function .....	3-1
Cohesive Sediment Theory .....	3-3
4. HYDROLOGIC MODEL .....	4-1
Boundary Conditions .....	4-1
Water Discharges .....	4-1
Water Temperatures .....	4-2

Downstream Water Surface Elevation Boundary Condition	4-2
Rating Curve Option	4-2
Water Surface Elevation Option	4-2
Rating Curve Override	4-2
Shift Option	4-2
Water Yield	4-3
Examples	4-3
<b>5. NODE TYPES</b>	<b>5-1</b>
Introduction	5-1
Sediment Routing Logic	5-1
<b>6. HYDRAULIC CALCULATIONS</b>	<b>6-1</b>
Introduction	6-1
Flow Direction	6-1
Known Water Discharges	6-1
Normal Backwater Calculations	6-1
Backwater with Reverse (Negative) Flows	6-2
Front-water	6-2
Program Logic for Mixed Flows	6-2
Unknown Flow Distribution	6-3
Closed Loop Hydraulics	6-3
Prescribed Flow Distribution	6-6
Energy Loss Equations	6-7
Hydraulic Parameters for Sediment Calculations	6-7
Hydraulic Parameters	6-7
Composite Channel n-Values	6-7
Slope	6-8
Velocity	6-8
Printout	6-8
Graphics	6-8
<b>7. SEDIMENTATION CALCULATIONS</b>	<b>7-1</b>
Sediment Inflow	7-1
Sedimentation Processes	7-1
Sequence of Calculations	7-1
Hydraulic Parameters	7-1
Surface Area	7-1
New Wet-Bed Weight	7-2
Flow-through Time	7-2
Settling of dredged material	7-2
Local Inflow/Outflow	7-2
Settling Velocities	7-2
Consolidation	7-2
Gradation of Active plus Inactive Layers	7-2
Deposition and Entrainment coefficients	7-2
Characteristic Rate of Entrainment	7-2
Characteristic Rate for Deposition	7-3
Bed Shear Stress	7-3
Silt and Clay Transport	7-3
Cohesive Sediment Deposition	7-3
Cohesive Sediment Erosion	7-4
Influence of Clay on the Active Layer	7-5

Mudflow Constraint on Transport Potential .....	7-5
Armor Layer Stability .....	7-5
Equilibrium Depth Calculation .....	7-5
New Active Layer thickness .....	7-5
Gradation of New Active Layer .....	7-6
Transport Potential for Non-Cohesive Sediment .....	7-6
Correction Factor for High Concentration of Fines .....	7-6
Concentration Equations .....	7-6
Maximum Allowable Transport .....	7-7
Sediment Outflow from Reach .....	7-12
New Active Layer Gradation .....	7-12
Trap efficiency .....	7-12
Bed Change-Sediment Movement .....	7-12
Residence time .....	7-12
8. BED ELEVATION CALCULATIONS .....	8-1
Bed elevation changes .....	8-1
Deposition and Erosion Limits .....	8-1
Smoothing Cross Section Elevations .....	8-1
Theory .....	8-3
Limiting Slopes .....	8-4
Two Foot Test .....	8-4
Mass Conservation .....	8-4
Trace Printout .....	8-4
Smoothing Command .....	8-4
Example .....	8-5
Change in Average Bed Elevation .....	8-5
Approach .....	8-5
Initial Average Bed Elevation .....	8-6
Change in Average Bed Elevation .....	8-6
9. DREDGING .....	9-1
Introduction .....	9-1
Dredging Options .....	9-1
Dredging Sites .....	9-1
Establishing Dredging Sites with H or HD-Records .....	9-1
Establishing Dredging site with HI or HL-Records .....	9-1
Dredging Rates .....	9-2
Example .....	9-2
Theory .....	9-3
Average End Area Method .....	9-3
Dredging by Bed Layer .....	9-3
Dredged Material Disposal .....	9-6
Sediment Deposition in the Dredged Reach .....	9-6
10. MBH GRAPHICS .....	10-1
Introduction .....	10-1
The \$PLOT Command .....	10-1
Making Screen and Hard Copies with MBH-PLOTTER .....	10-5
Opening a Plot file .....	10-5
Plotting all frames .....	10-5
Selecting the Plot Frame .....	10-5
Over plots .....	10-5

Legend .....	10-5
Printing all Plots .....	10-6
Printing a Single Plot .....	10-6
Linking Segments Together .....	10-6
Deleting Plot Frame .....	10-6
Saving Plot Commands .....	10-6
Attaching an Existing Plot Command File .....	10-6
Error and Diagnostic Message Numbers .....	11-1
Status of Diagnostic and Error Messages .....	11-1
Introduction .....	C-1
Network Structure .....	C-1
Geometric Data .....	C-2
Sediment Data .....	C-3
Hydrologic Data .....	C-4
General .....	C-4
Network Structure .....	C-5
Coding the Q Record .....	C-5
Example .....	C-5
Boundary Conditions .....	C-6
Examples .....	C-8
EXAMPLE NO. 1. SIMPLE TEST USING P-RECORD MODEL EXTENSION. NO LOCALS .....	C-8
EXAMPLE NO. 2. TEST LOCAL INFLOW OPTION .....	C-9
EXAMPLE NO. 3. TEST 3 BRANCHES WITH 1 JUNCTION .....	C-12
EXAMPLE NO. 7. WAX LAKE OUTLET DISTRIBUTARY... LOWER ATCH RIV SEGMENT .....	C-14
EXAMPLE NO. 8. TEST ISLAND FLOW CALCULATION. SEGMENT 1= D/S FROM ISLAN .....	C-16
EXAMPLE NO. 14. ONE LOCAL AND 1 JUNCTION, CODED IN V4.00 SYNTAX ....	C-19
EXAMPLE NO. 19. TEST BED/BANK COMPOSITING AND ENCROACHMENTS, HEC2 FMT. ....	C-22
EXAMPLE NO. 26. TEST TWO LOOPS, WET/DRY WITH DREDGING. SEGMENT 1= D/S .....	C-24
EXAMPLE NO. 29. TEST LOCAL OUTFLOW OPTION USING QP-RECORDS .....	C-28
EXAMPLE PRINTOUT .....	D-1
Banner .....	D-1
Geometric Data Printout .....	D-1
Sediment Data Printout .....	D-1
Hydrologic Data Printout .....	D-3
Annotated A-Level printout from Hydraulic Calculations .....	D-15

## **INPUT DESCRIPTION FOR GEOMETRY DATA .....** E-1

INTRODUCTION .....	E-1
E-1 \$SEG-Record - Segment Record (Required) .....	E-2
E-2 Title Records (T1 - T3) .....	E-3
E-3 Job Parameter Options .....	E-4
E-3.1 P-Record .....	E-4
E-3.2 PX-Record - Cross Section Template .....	E-6
E-4 Manning's n-Value Options (required data) .....	E-8
E-4.1 NC-Record - Constant N-Values Plus Expansion/Contraction Coefficients .....	E-8

E-4.2	ND-Record - Vary N-Values by Depth (optional)	E-10
E-4.3	NK-Record - Calculate N-Values (optional)	E-12
E-4.4	NM-Record - Cowan's M for Energy Loss in Meanders (optional)	E-13
E-4.5	NV-Record - Vary N-Values by Elevation or Discharge (optional)	E-15
E-4.6	NX-Record - Horizontal Variation of n-Values Option	E-17
E-5	Local Inflow/Outflow Options	E-23
E-5.1	QP-Record - Local Outflow as Percent	E-23
E-5.2	QT-Record - Local Inflow/Outflow Location (optional)	E-24
E-5.3	QL-Record (optional)	E-25
E-6	X1-Record - Cross Section Location (required)	E-27
E-7	XB-Record - Separate Channel Bed from Banks (optional)	E-29
E-8	XC-Record - Reach Lengths for XB-Record	E-31
E-9	X3-Record - Ineffective Flow and Encroachments (optional)	E-32
E-10	X5-Record - Hydraulic Control Point (optional)	E-34
E-11	XL-Record - Conveyance and Cross Section Limits (optional)	E-35
E-12	GE-Record - Cross Section Coordinate Editor	E-37
E-13	GR-Record - Cross Section Coordinates (required)	E-38
E-14	The Bed Sediment Reservoir (Required Data)	E-39
E-14.1	H-Record - Elevation Option for Prescribing Bed Sediment Reservoir	E-39
E-14.2	HD-Record - Depth Option for Prescribing Bed Sediment Reservoir	E-43
E-14.3	HE-Record - Erosion Limits	E-46
E-14.4	HI-Record - Add Stations Option for Prescribing Bed Sediment Reservoir	E-48
E-14.5	HL-Record - Multiple Dredging Sites	E-51
E-15	EJ-Record (required)	E-54
E-16	\$TRIB-Record - Tributary Inflow Point (optional)	E-55
E-17	CP-Record - Control Point Identification (optional)	E-56

**INPUT DESCRIPTION FOR SEDIMENTARY DATA** . . . . . F-1

F-1	Title Records - Comments (five required - T4 - T8)	F-1
F-2	I1-Record - Continued	F-2

**I1**HEC-6 Input Description**I1**

Sediment Properties and Transport Functions

<b>F-2</b>		F-2
F-3	I2-Record - Parameters Required for Clay Transport (optional)	F-4
F-4	I2-Records(Continued) -Cohesive Sediment Transport Method 2:	F-6
F-5	I3-Record - Parameters Required for Silt Transport (Continued)	F-8
F-5	I3-Record - Parameters Required for Silt Transport (optional)	F-8
F-6	IX-Record - Cross Sections where Fine Sediment Coefficients Change (optional)	F-10
F-7	I4-Record - Parameters Required for Sand Transport (optional)	F-11
F-8	I5-Record - Coefficients for Numerical Integration Method (optional)	F-14
F-9	I6-Record - Concentrations for Flow Classification (optional)	F-16
F-10	J and K-Records - User Specified Transport Function (optional)	F-17
F-11	LQ-[LT, LC]-LF-Records - Sediment Inflow Boundary Condition (required)	F-19
F-11.1	LQ-Record - Water Discharge for the Inflowing Sediment Load Relationship (required)	F-19
F-11.2	LT (or LC)-Record - Total Sediment Inflow (required)	F-20
F-11.3	LF-Record -Fraction of Inflowing Sediment Discharge in each grain size class (required)	F-22
F-12	LQ-SD-Records - Sediment Distribution Coefficients at a Junction	F-23
F-12.1	LQ-Record - Water Discharge for Sediment Distribution Coefficients at a Junction	

	.....	F-23
F-12.2	SD-Record - Sediment Distribution Coefficient at a Junction .....	F-24
F-5	I3-Record - Parameters Required for Silt Transport (Continued) .....	F-25
F-13	N-Record - Bed Material Gradation (Continued) .....	F-25
F-13	N-Record - Bed Material Gradation .....	F-25
F-14	PF-Record - Bed Material Gradation .....	F-27
F-15	OF-Record - Active Layer Gradation (Optional) .....	F-28
F-16	\$LOCAL Option - Local Inflow and/or Outflow Points .....	F-30
F-16.1	\$LOCAL-Record .....	F-31
F-16.2	Case 1: LQL-[LTL, LCL]-LFL The Local entry point is only inflows (i.e. <u>no</u> diversions are present.) .....	F-31
F-16.3	Case 2: LQL-LTL-LFL The Local Inflow/Outflow Point Contains only Outflows (i.e. diversions) .....	F-34
F-16.4	Case 3: LQL-[LTL, LCL]-LFL Combined Diversions and Inflows .....	F-37
F-16.5	Case 4: LQL-LTL-LFL-Records when using QL-Records .....	F-39

## **INPUT DESCRIPTION FOR HYDROLOGIC DATA** ..... G-3

G-1	\$HYD-Record - Hydrologic Model (required) .....	G-3
G-2	*-Record - Comment and Print Control (required) .....	G-4
G-3	Q-Record - Water Discharge Entering the Model(required) .....	G-7
G-4	R-Record - Downstream Water Surface Elevation Boundary Condition (required) .....	G-8
G-5	S-Record - Rating Shift (Optional) .....	G-10
G-6	T-Record - Water Temperature (Optional) .....	G-11
G-7	W-Record - Computation Time Step (required) .....	G-12
G-8	X-Record - Alternate Format for Coding Computational Time Step .....	G-13
G-9	\$END-Record - Required .....	G-16

## **SPECIAL COMMANDS AND PROGRAM OPTIONS** ..... H-19

H-1	\$AV Record - Compute Surface Area and Volume of Storage in Model (Optional) .....	H-19
H-1.3	VJ Record - Elevation Table for Cumulative Volume Computations (Optional) ...	H-21
H-1.4	VR Record - Elevation Table for Cumulative Volume Computations (Required when using VJ-Record) .....	H-22
H-2	\$B-Record - Transmissive Boundary Condition (optional) .....	H-1
H-3	\$CL-Record - Closed Loop (Optional) .....	H-2
H-4.1	\$DREDGE -Record - Dredging Option .....	H-3
H-4.2	\$NODREDGE Record - Stop Dredging .....	H-3
H-4.3	DF-Record - Draft Option .....	H-4
H-4.4	DC-Record - Dredging Capacity .....	H-5
H-5	\$EX-Record - Exner Options .....	H-6
H-6	\$GR-Record - Cross Section Shape Option .....	H-7
H-7	\$HOT-Record - Resume a Run .....	H-8
H-8	\$K-Records - Channel N Values by Relative Roughness (Optional) .....	H-9
H-9	\$MXMN - Save Maximum and Minimum Values (Optional) .....	H-10
H-10.2	QC-Records - Flow Distribution Coefficient Records .....	H-12
H-10	\$OQC Data Set - Flow Distribution Coefficients .....	H-12
H-10.1	\$OQC-Record - Command Record .....	H-12
H-11	\$PLOT-Record - Plot Option .....	H-14
H-12	\$PRT-Record - Selective Printout Option .....	H-16
H-12.1	CP-Record - Control Point for Selective Printout .....	H-17
H-12.2	PN-Record - Cross Section Sequence Number for Selective Printout .....	H-17
H-12.3	PS-Record - Cross Section Identification(River Mile) for Selective Printout .....	H-18

H-13	\$RATING - Tailwater Rating Curve Boundary Condition (Optional) . . . . .	H-19
	H-13.1 \$RATING Command Record . . . . .	H-19
14	\$RE Record - Recirculate Option . . . . .	H-21
	H-15. \$SCRT-Record - Supercritical Flow Option . . . . .	H-23
H-16	\$SED-Record - Water Discharge-Sediment Load Table (Optional) . . . . .	H-24
	H-16.1 LP-Record - Inflow Point Identification for Changing the Inflowing Load Table (Optional) . . . . .	H-25
	H-16.2 LR-Record - Ratio for Changing the Sediment Load Table (Optional) . . . . .	H-26
	H-16.3 LRATIO-Record - Ratio for Changing Sediment Load Table (Optional) . . . . .	H-27
	H-16.4 END-Record - Termination Record for the \$SED Option . . . . .	H-28
H-17.	\$SMOOTH-Record - Smoothing Command . . . . .	H-29
H-18	\$SUBSID-Record - Subsidence Option . . . . .	H-31
H-19	\$TAPE12-Record - End of Run Data Set (Optional) . . . . .	H-28
H-20	\$UNET-Record - Unsteady Flow Hydrograph at every Cross section (Optional) . . . . .	H-32
H-21	\$VOL-Record - Compute Cumulative Volume and Deposits at all Sections (Optional) . . . . .	H-33
	H-21.1 VJ -Record - Elevation Table for Cumulative Volume Computations (Required when using \$VOL) . . . . .	H-34
	H-21.2 VR-Record - Elevation Table for Cumulative Volume Computations (Required when using \$VOL-Record) . . . . .	H-34
H-22	\$WRITE-Record - Write a Resume File (Optional) . . . . .	H-35
H-23	\$WSCP-Record - Water Surface Elevation Control Points (Optional) . . . . .	H-36



# 1. INTRODUCTION

## Purpose and Scope

The purpose of this manual is to supplement the HEC-6 User's Manual Dated August 1993. The scope is limited to instructions for coding input data and locating the output. More than two dozen examples are provided in Appendix C to illustrate the organization of data files.

## Instructions for Installing HEC-6T

**Distribution disk.** The installation CD contains the executable and a subdirectory of example data sets for HEC-6T, the Shell, the Editor and the program to convert HEC-RAS geometry files to HEC-6T format.

**Install HEC-6T.** Instructions for installation and setting preferences are given in the README file

## Instructions for Executing HEC-6T

**General Description.** HEC-6T is executed from the "MBH Shell."

**Files.** HEC-6T expects input data to be in a file with a **.T5 extension.**

HEC-6T will execute and three output files will be written as follows

.T6	the calculated results .. which was <b>TAPE6</b> in previous versions of the code.
.T12	the cross sections at the end of the run .. which was <b>TAPE12</b> in previous versions of the code, and
.T98	the plot file .. which was <b>TAPE98</b> in previous versions of the code.

**Screen.** The program will scroll

**Event Number, Water Surface Profile Number and \*-Record title**

to the screen as the calculations proceed. When calculations are finished the program will write the following information on the screen followed by the DOS prompt.

```
READING INPUT DATA FROM file_name      = EX01.T5
PRINTOUT WRITTEN TO file_name            = EX01.T6
END OF RUN GEOMETRY WRITTEN TO file_name = EX01.T12

      0 FATAL DATA ERRORS DETECTED.
```

2 INFORMATION MESSAGES DETECTED.

TOTAL NO. OF EVENTS READ= 1  
TOTAL NO. OF WS PROFILES= 1  
ITERATIONS IN EXNER EQ = 50

END OF JOB  
13:54:05.19 05/21/97

## Output

Three types of output are available, printout, graphs and end-of-run geometry. Printout is written as the input data file is read. Therefore, one can view the .T6 file and determine how far the computations got in the input data file. See Appendix D for details about program output.

**Print-out.** Printout must be requested. The procedure is discussed on the \*-Records in the Hydrological Data Set. Printout is written to file with a .t6 extension. It can be viewed by clicking the View Output button on the shell.

**Graphics.** The MBH graphics utility "MBH Plot" will provide a variety of graphs. It is a two step process as described in Chapter 9 of this document. The first step is to select the variables from the list described on the \$PLOT-Record in appendix G, "Input Description, Program Commands," and execute HEC-6T to produce the graphics file. It is an ASCII file named **file\_name.t98**. The second step is to plot the graphs using the plotter code MBH which runs under WINDOWS.

**TAPE12.** The final cross section coordinates from the HEC-6T simulation are written to the input file name with a .T12 extension. This file is written automatically. Tape12 is not a complete Geometric Data Input file, but it can be edited into a input file for HEC-2 or HEC-6.

## Input Data

Prepare the input file before executing HEC-6T. The file organization and required data records are shown in Appendix C, "Input Data Structure." Instructions for coding the data records are shown in Appendices E, F, G and H. The sequence of records in these instructions is the sequence that the program expects when it reads the input data file.

An efficient approach for developing the input data is to locate one of the example problems in Appendix C that resembles the problem to be analyzed. Locate the input data file for that example and convert the records in that example input data file by replacing them with data that describes the new problem. **NOTE: The data in Appendix C are not for general use; all values in Appendix C are hypothetical. These example data sets merely show how to select and organize data record types in the sequence the computer program expects.**

The input data file name can be any that DOS permits, but the file extension must be **.T5**.

Data in this user's manual are organized into four categories, Geometric Data, Sedimentary Data, Hydrologic Data and Program Commands, and when the job is large, the author prepares each category in its own data file. However, the program reads only one input file. Therefore, if subfiles are used, copy them into a single file before execution.

## Data Edit

Two types of data editing are provided. The first is a record sequence. The program expects records in a certain sequence. When it fails to find that sequence, it will print an error message, set a NOGO switch, and read the rest of that data type for **sequence** before aborting the run.

The second type of data editing is provided in the Geometric and in the Sedimentary Data sets by typing a C on the first Title record in each of those respective data sets. The program will print a detailed account of how it interprets the input data. This account is printed as the data are read.

In addition to the detailed printout, the program will check cross section stations and strip boundaries for increasing size when the C-level option is requested on the T1-Record. When successive cross section stations give a negative width, a fatal error message will be printed. The program will set the NOGO switch and check the rest of that data type before aborting the run. This level of editing is very useful for screening a new geometric model. However, when the "S" style coding for bridges has been used, the cross section stations will decrease. Even though coded correctly, that data set will give a fatal error and abort the run. To avoid that condition, turn off the edit option.

One can locate error messages in the printout by searching for the string, ERROR.



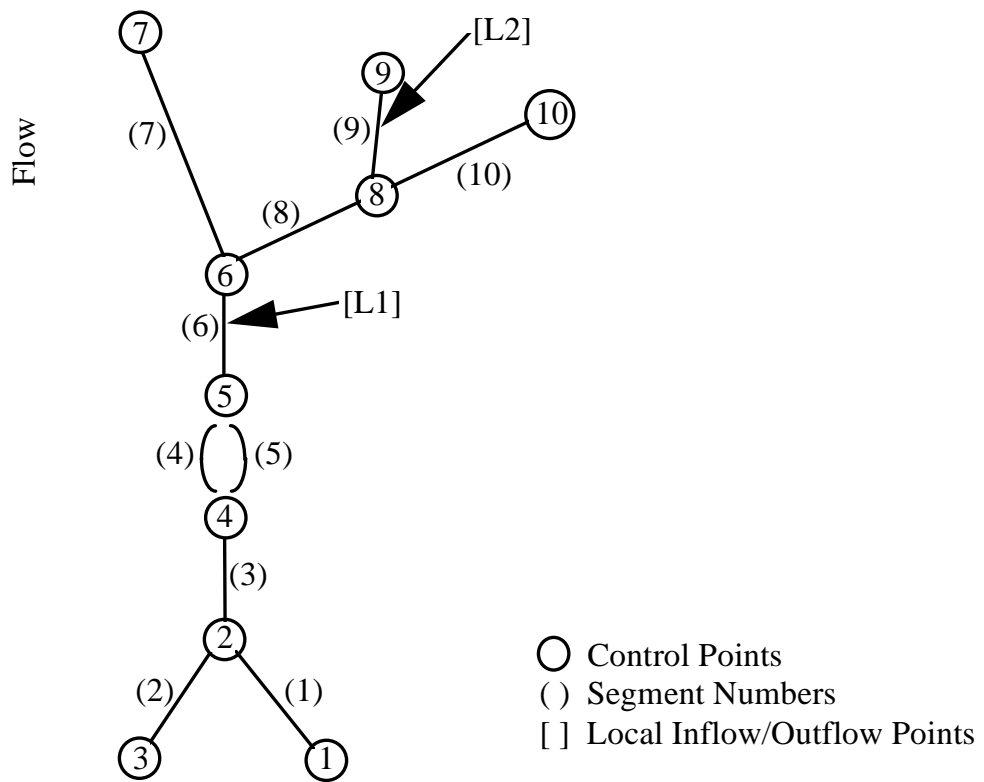

**Branches and Control Points.** Control points are shown as circles and segments as the lines connecting the circles in the above figure. The network should start at the downstream end of the study area and proceeds upstream. The schematic of a stream network is formed by branches and control points.

The simplest network consists of a single branch with one inflow point and one outflow point. It could be depicted in the Figure 2.1 by erasing all segments except Segment 1 and all control points except Control Points 1 and 2.

**Junction Control Points.** If a tributary exists, the tributary would join the mainstem at a junction control point. Figure 2-1 illustrates the arrangement at control points 6 and 8.

Tributaries and Local inflows can be prescribed using the QT-Record in the Geometric Data Set just as in the original HEC-6 code. However, when a QT-Record is read, the program logic has been completely re-designed for Version 4.00. For example, the original Network Version of HEC-6 created an "INTERNAL JUNCTION" when the data set included QT-Records with a 2 or larger number in field 1. That signified that a Tributary Geometry Data Set was present at that inflow point. That data would follow the mainstem data and be identified by a \$TRIB-Record followed by a CP-Record which assigned the geometry to the internal junction point number. However, the code did not form a new branch upstream from that QT-Record. The current version, Version 4.00 and higher, Network Structure **will form a new branch** when it reads such a QT-Record.

**Distributary Control Point.** HEC-6T will allow one distributary. That is depicted as Segment 2 in Figure 2-1. Notice the distributary connects control point 3 with control point 2. That will cause the program to issue a warning message because it expects control point numbers to always increase in the upstream direction. However, the program will process the data and establish the distributary. The downstream boundaries of this network would be control points 1 and 3. These must be coded on the \$WSCP-Record in the Program Commands Input Data. The WES Research Version HEC-6W, does not allow a distributary.

**Island Flow.** HEC-6T allows simple closed loops such as shown between control points 4 and 5 in Figure 2-1. When running such a network always begin the Hydrologic Input Data Set with a \$CL-Record. That tells the program that closed loops exist in the network.

## Cross Sections and Reach Lengths

The geometry of each branch is developed by cross sections and reach lengths. The cross sections are coded from downstream to upstream in direction, and the reach length, i.e. the distance between two cross sections, is coded on the upstream cross section of the reach.

## Data Sequence

The network is always developed from downstream to upstream in direction. Therefore, branch 1 geometry will be coded first in the data file. Program logic depends on the fact that each branch has two ends: a downstream end and an upstream end. These ends are not arbitrary. The downstream end of the branch is always the first cross section, for that branch, in the data file. The last cross section for a branch is the upstream end of that branch.

## Direction of Flows

The direction of flows on a branch can be toward the downstream end, toward the upstream end, or mixed. A network can have positive flow in some branches and negative flow in others. The direction is depicted by including the sign of the water discharge,  $Q$ , at every cross section. A positive  $Q$  means water is flowing toward the

downstream end of the branch at that cross section. A negative Q means water is flowing toward the upstream end of the branch. The flow direction is combined with cross section sequence numbers and upstream end-downstream end branch control point logic to develop the computational logic for sequencing the hydraulic and sedimentation calculations.

## Local Inflows/Outflows

The local inflow/outflow option allows an inflow or outflow of water and sediment to be prescribed along the channel bank in any reach of the branch. It does not create a control point or require a geometric data set. These values are regarded as boundary conditions although they do not satisfy the unknowns which are generally associated with boundary conditions.

## Control Points

The two types of Control Points in a Network have been introduced already: The Boundary Condition Control Point and the Junction Control Point. Their attributes are significant in the flow of computations.

**Boundary condition control points.** A Boundary Condition control point has 1 branch. It will always require a boundary condition to satisfy the number of unknowns. Two categories of data are prescribed at boundary control points. The base level control is prescribed at model outflow boundaries and the inflowing water discharges and sediment concentrations by grain size are prescribed at inflow boundaries. These Boundary Control Points are assigned a TYPE Number in variable IDBVT(ncp).

**Junction control points.** A junction is where branches of the network join. It is internal: i.e. there will always be 2 or 3 branches adjoining a junction. Table 2-1 shows possible flows at junctions.

If there are 2 branches, one will be the inflow and the other will be the outflow branch.

If there are 3 branches, program logic must be developed to determine which is/are the inflow and which is/are the outflow branches for each discharge event.

Water mass, sediment mass and heat energy are always conserved in a junction. However, a table of coefficients, ranging from 0 to 1 by particle size class, is provided to regulate how much sediment will pass into each outflow branch when there are more than one outflow from the junction. These coefficients must be determined by field measurement or physical model studies because the sediment will not always go in proportion to the water discharge.

The water surface elevation is always horizontal across the junction. However, the code will allow an energy loss at the cross section adjoining a 2-branch junction on the U/S side. That mimics the traditional X5 option for head loss in HEC-6. **Reverse flows can not be run when using the X5-Option.**

## Internal operating rules (X5-Records)

An internal operating rule refers to a water discharge-elevation control such as a dam or weir. These controls are prescribed on an X5-Record in the Geometric Data Set. The logic is shown in the programmer's manual.

The values of the X5 option are to assign a water surface elevation, or, in some cases, to avoid short reach lengths. The rules for the number of cross section in a control volume are the same as in HEC-6.

In the original HEC-6 Code, an X5-Record would establish internal control volume boundaries on the

branch. Water and sediment volumes entering and leaving each control volume were calculated, and the discharges were passed from one control volume to another.

In the HEC-6T code, the X5-Record breaks the model computations into control volumes as if a junction point were encountered, but the Segment Number does not change. Water and sediment discharges still pass from one control volume to another; and the change in water surface elevation across the control volume boundary is still controlled by the Operating Rule Criteria. However, the SA-1 table is not partitioned to show inflow/outflow volumes, and trap efficiency is not calculated for each control volume. Therefore, to get sediment inflow, outflow and trap efficiency for control volumes which are shorter than the segment length, use the \$VOL option.

## **Deposition and Erosion Limits**

The 1993 version of HEC-6 combines the deposition and erosion limits, and they are prescribed on the H or HD-Records. However, when XL-Records, (Conveyance Limits - See Input Description of Geometric Data) are used, the program automatically partitions the cross section into deposition and erosion zones based on the conveyance limits. That is, deposition is allowed based on the limits of the movable bed prescribed on H or HD-Records, but erosion is restricted to the conveyance limits portion of the cross section. That technique continues in Version 2.10 of the code designated as the WES Research Version (HEC-6W).

That practice is discontinued in HEC-6T beginning in **Version 4.30 Dated June 1995**. A new record type, the HE-Record, was created for prescribing erosion limits. The H and HD-Records still prescribe the general characteristics of the bed sediment Reservoir including the deposition limits. When no HE-Records are present, the erosion limits are the same as the deposition limits. However, in those cases when it is desirable to assign erosion to different limits than deposition, use the HE-Record.

Erosion limits are no longer restricted to the conveyance limits.

TABLE 2.1 FLOW AT JUNCTION CONTROL POINTS

FLOW AT CONTROL POINT	VALUES ASSIGNED
<p style="text-align: center;">           U/S                                      v            U/S -----&gt; 0 -----&gt; D/S         </p> <p>2 BRANCHES IN, 1 OUT</p>	<p style="text-align: center;">           NETCP(MXBR,MXCP)                          NGDS=3                         NGDS=2 V NGDS=1            -----&gt;0 -----&gt;            CP=2         </p> <p style="text-align: center;">           CP#            NETCP(NGDS=1,U/S=2)= 2            NETCP(NGDS=2,D/S=1)= 2            NETCP(NGDS=3,D/S=1)= 2         </p> <p style="text-align: center;">           NGDS            IBRCP(ncp=2,1) = 1            IBRCP(ncp=2,2) = 2            IBRCP(ncp=2,3) = 3            LXSCP(ncp) = 3         </p> <p style="text-align: center;">           IXSCP(ncp=2,1) = -NR<sub>1</sub>            IXSCP(ncp=2,2) = 1<sub>2</sub>            IXSCP(ncp=2,3) = 1<sub>3</sub> </p>
<p style="text-align: center;">                                     v            &lt;----- 0 -----&gt;         </p> <p>1 BRANCH IN, 2 OUT</p>	
<p style="text-align: center;">                                     v            -----&gt; 0 &lt;-----         </p> <p>3 BRANCHES IN, 0 OUT</p>	<p>IMPOSSIBLE CONDITION</p>

<p style="text-align: center;">^     &lt;-----0-----&gt; 0 BRANCHES IN, 3 OUT</p>	<p>IMPOSSIBLE CONDITION</p>
<p style="text-align: center;">-----&gt;0-----&gt; 1 BRANCH IN, 1 OUT</p>	

## Coding Bridge Cross Sections

**Cross Section Layout.** HEC-6 calculates hydraulic losses at bridges using n-values and the coefficients of contraction and expansion. Three cross sections are required. Therefore, the HEC-2 data file must be converted by modifying the bridge cross sections. The process consists of reducing the number of bridge cross sections from 4 to 3 and relocating them as shown in Figure 2-2.

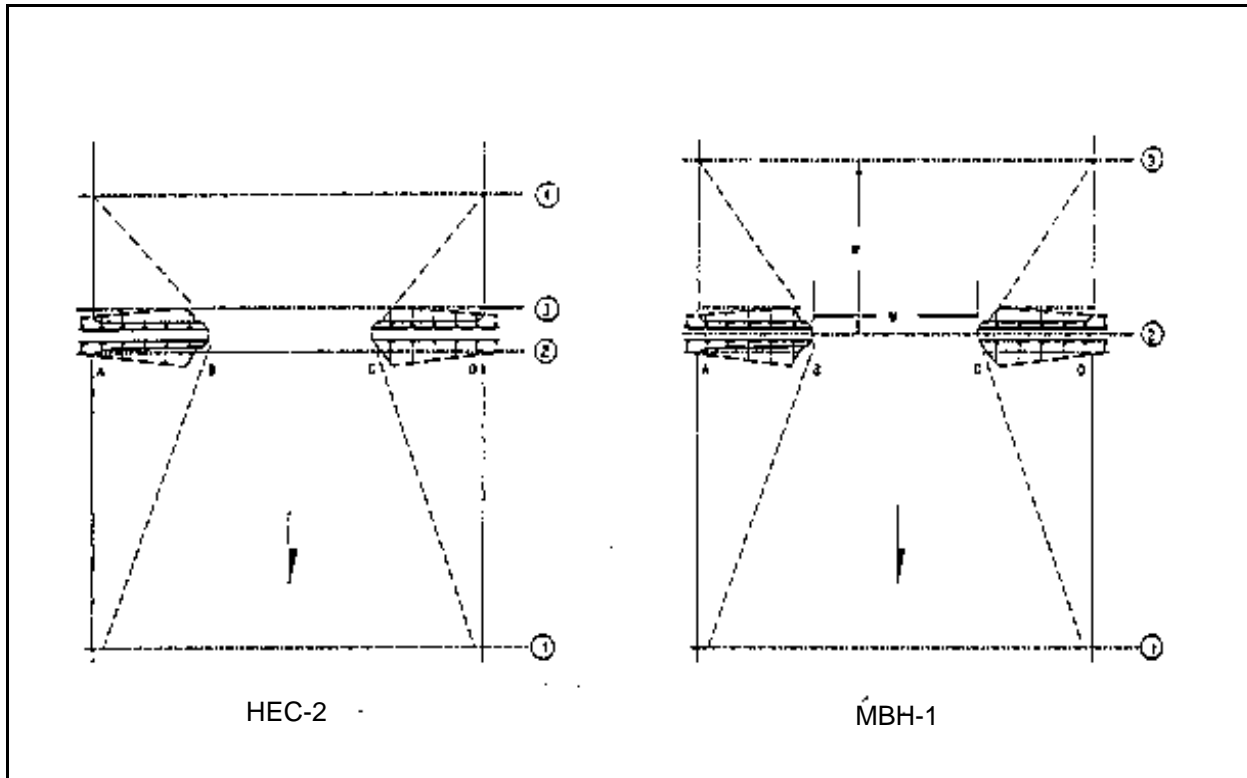

**Figure 2-2.** Cross Section Layout at Bridges, HEC-6T.

**Coding Bridge Cross Sections.** HEC-6T does not read BT-Records. Consequently, the deck and roadway could not be coded in the original version of the code. That problem has been relieved by implementing a "S-type" coding technique. In this technique, the channel cross section and bridge piers are coded as the bottom part of the "S." Before reaching the right channel station, the cross section is extended vertically upward to the bottom cord of the bridge, and the bottom of the deck structure is coded by proceeding from right to left. That is like the middle of the "S." Upon reaching the left channel station, the cross section is extended vertically, again, and the elevations along the top of roadway are coded. That is like the top of the "S." Outside of the channel subsection, the cross section can be coded as usual.

The following example illustrates this technique. The bold numbers are the left approach to the bridge plus the channel and bridge piers. This forms the bottom of the "S." The shaded numbers are the bottom of the bridge superstructure. The italic numbers are the top of roadway. Figure 2-3 shows a plot of this cross section.

```
* PR-151 BRIDGE      X1      4.1
X1 2184          38 1016.70 1167.30      206.      155.      165.      0.95      0.      0.
GR 497.      616.70 496.36 676.70 494.13 776.70 492.20 886.70 491.61 966.70
GR491.33 1016.70 485.07 1016.71 482.56 1027.14 483.12 1033.12 483.77 1065.87
GR488.84 1065.87 488.84 1067.35 483.77 1067.35 482.37 1092.30 482.09 1106.05
GR481.46 1116.59 488.68 1116.59 488.68 1118.07 481.46 1118.07 480.61 1143.85
GR479.48 1167.29 488.22 1167.30 488.68 1118.07 488.68 1116.59 488.84 1067.35
GR488.84 1065.87 488.96 1016.70 491.33 1016.70 491.17 1065.87 491.17 1067.35
GR491.04 1116.59 491.04 1118.07 490.58 1167.30 490.65 1167.31 489.97 1272.25
GR491.62 1331.25 494.90 1380.45 498.18 1462.55
HD 4.1          10. 1016.8 1167.29
HE 4.1          1016.8 1167.29
```

It is very important for the bottom of the "S" to end before it reaches the right channel station. That is 1167.30 in this case. It is very important that the middle of the "S" ends before it passes the left channel station, which is 1016.70 in this case.

It is also important that the limits of the movable bed be reached before the bottom of the "S" ends. Otherwise, the bridge deck will move vertically in response to scour or deposition of the bed. In this case, station 1167.29 is the first fixed point on the right side of the cross section. That corresponds to the end of the "S."

This technique will allow the bridge pier elevations to move if they are below the water surface. Therefore, it is important to inspect the final cross section carefully before accepting the results.

**No Special Bridge Routine.** There is no Special Bridge option in HEC-6. Therefore, the SB-Records must either be removed from the data file or made inactive.

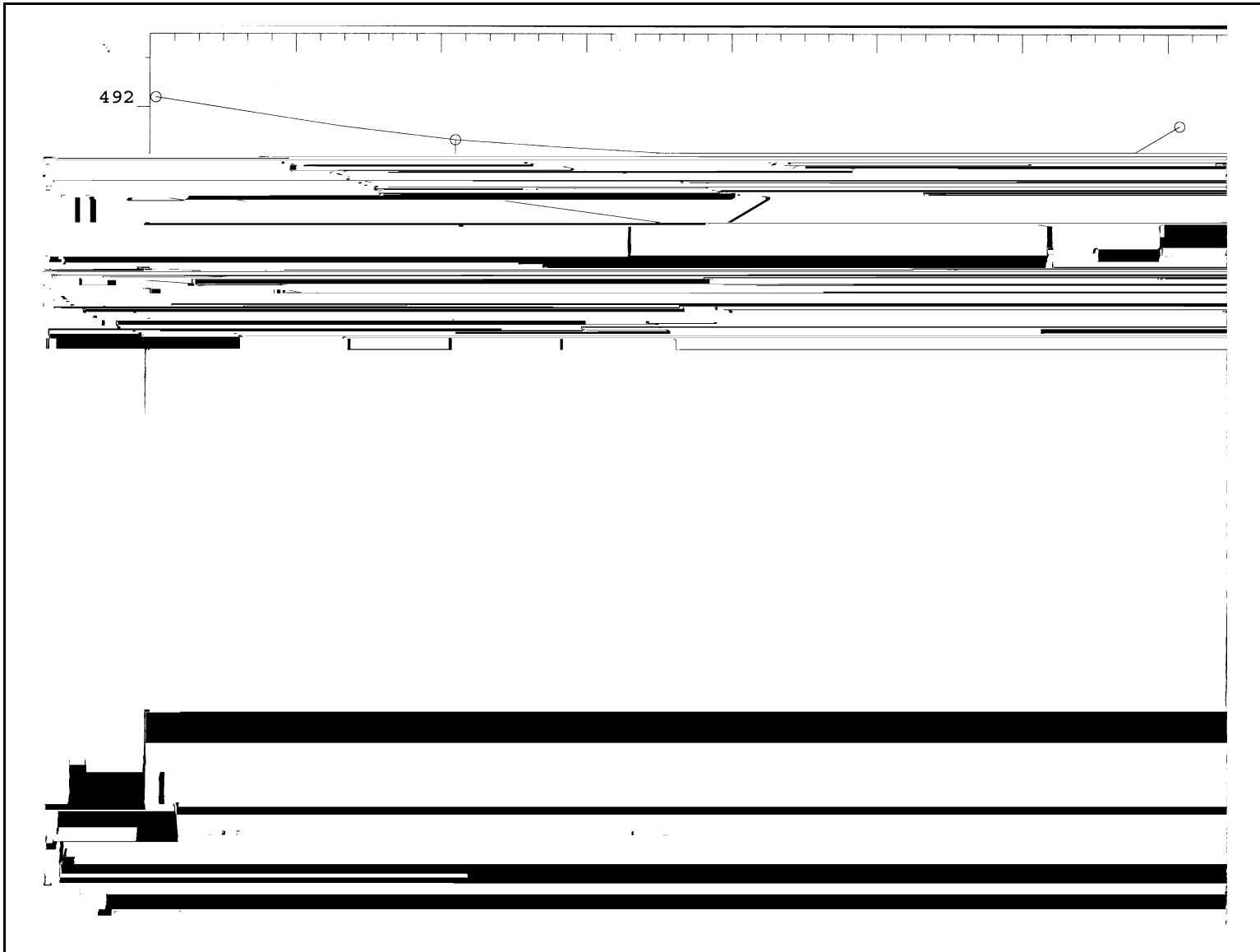

Figure 2-3. S-type Coding for Bridge Cross Sections



### 3. SEDIMENTARY MODEL

#### Introduction

The new branch structure in HEC-6T will require some modifications to the HEC-6 sediment data input. For example, the original HEC-6 network structure considered the main channel as one branch even when tributary junctions were present. Therefore, only one sediment data set was needed for that entire main channel branch. The inflowing sediment discharge table was present as well as bed gradation curves.

The input for HEC-6T will establish a new geometric data segment at each tributary junction, and the program will expect a bed gradation data set for each one of those segments. The inflowing sediment discharges will only be coded for the most upstream branch. A Control Point number, CP-Record, is required just prior to the inflowing load table. The I1 - I5-Records are coded for Segment 1 only. All other segments use that same data set.

#### User Supplied Sediment Transport Function

This function is a graph of sediment transport, tons/day/foot of width, versus the Depth\*Slope product as illustrated in Figure 3.1. The transport function is expressed by the equation:

$$GP = ((DS-C)/A)^B$$

where DS is depth times slope, and coefficients are A, B and C. An equation is required for each grain size fraction being evaluated. These are coded on J-Records as shown in Figure 3-2.

The user supplied transport function option requires a roughness equation even if the correction coefficient is 1.0. That equation is coded on the K-Record, expressed by the equation:

$$STO = D \cdot n^E$$

When this option is used, J and K-Records should be inserted into each Segment of the model.

NOTES:

Coarse Sand, 1.0 - 0.5 m.m., geometric mean size 0.707 m.m.  
 Medium Sand, 0.5 - 0.25 m.m., geometric mean size 0.354 m.m.  
 Fine Sand, 0.25 - 0.125 m.m., geometric mean size 0.177 m.m.  
 Very Fine Sand, 0.125 - 0.062 m.m., geometric mean size 0.088 m.m.

Load corrections apply to sediment load values read from

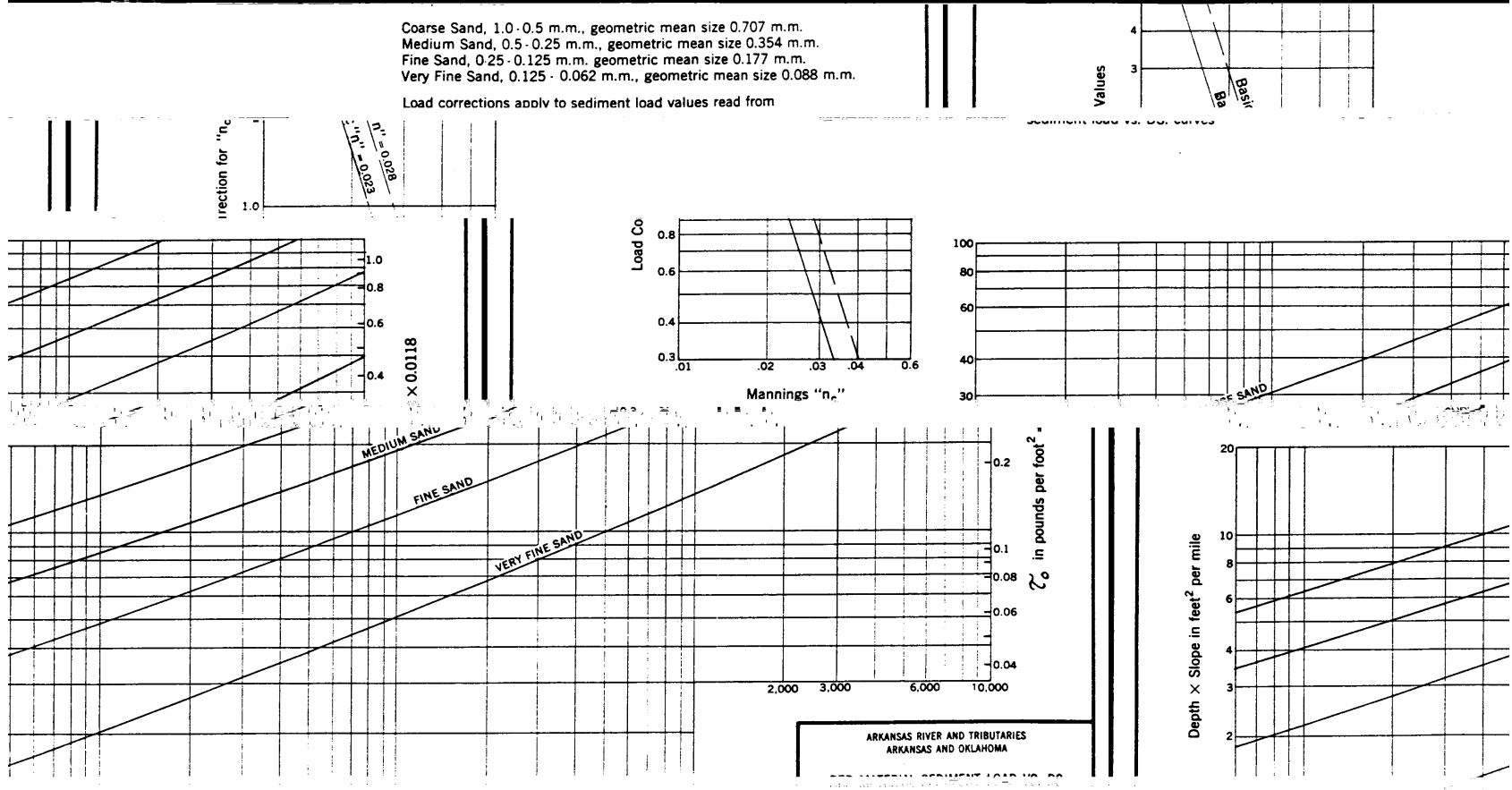

Figure 3-1. User Supplied Transport Function

## **Cohesive Sediment Theory**

**Note:** The clay transport function was developed from experiments in which the suspended sediment concentrations were less than 300 mg/ (see Krone, 1962). Applications to field situations where suspended sediment concentrations may be greater than 300 mg/ will exceed the intended range of applicability of the relationships. Also note that the relationships for clay deposition were derived from one-dimensional channels where the velocity and sediment concentration profiles are reasonably uniform. Users may experience difficulty with clay deposition rates in deep reservoirs.



## 4. HYDROLOGIC MODEL

### Boundary Conditions

Boundary conditions refer to the water and sediment discharges entering the model and to the stage-discharge relationship prescribing the base level of energy. There are three external boundary condition parameters: water discharge, sediment discharge by particle size and tailwater elevation. The Sediment Boundary Conditions are coded on LQ-LT-LF-Records in the Sedimentation Input Data set, and the Hydrologic Boundary Conditions are coded on Records \*-Q R-S-T in the Hydrologic Input Data set.

The water and sediment discharges must be prescribed at each inflow point. Examples of inflow points are the main channel inflow at the upstream boundary of the model, the inflow point at the upstream end of each tributary, and each lateral inflow point along the length of the model. The base level boundary condition, i.e. the tailwater elevation, must be prescribed at each outflow control point.

There are sediment controls such as bank failure which add sediment material to the model. These are accommodated as a lateral inflow point.

Finally, there are structural features within a model where the stage discharge relationship is controlled by weirs or gates or diversion structures rather than by energy losses. These are referred to as internal boundary conditions. The controlling mechanism is the operating rule for the structure. The depth vs water discharge or depth vs time relationship must be prescribed.

The executive subroutine for reading Boundary Condition values is Subroutine BCMOD3. The hydrologic data for HEC-6T is fundamentally different from all earlier versions of HEC-6. The current data structure expects water discharges at inflow points. All earlier versions expected water discharges at outflow points. Single segment networks with no local inflows are backward compatible. When either junctions or local inflow/outflow points are present, data sets are not always backward compatible even though a special program logic has been developed to read those historical data sets. The special logic is discussed in the Hydrologic Model section of the Programmer's Manual.

For example, the Network Schematic in Chapter 2 has 3 control points which require inflowing water and sediment boundary conditions. These are Control Points 7, 9 and 10. There are two outflow control points. They are Control Points 1 and 3. A tailwater elevation is required for Control Points 1 and 3, and water discharges and sediment inflows by particle size are required for Control Points 7, 9 and 10. In addition, there are two local inflow/outflow points. These are not control points since they do not create a new segment number. However, they are like external control points because flow crosses the model boundaries. Consequently, they do require water and sediment boundary conditions. The following paragraphs describe program options for prescribing boundary conditions.

### Water Discharges

Water discharges, sometimes referred to as the Q-BC, are prescribed for each External Control Point at which flow enters the model. The program then assigns the water discharge to each cross section in the network using logic controlled by Subroutine BCMOD3.

## Water Temperatures

Water temperatures are not considered a Boundary Condition since there are no heat equations in this code. However, water temperature is needed for sediment and hydraulic calculations. The value must be determined externally. It is read using logic similar to the Q-BC logic and assigned to each cross section. The logic is controlled by Subroutine BCMOD3.

## Downstream Water Surface Elevation Boundary Condition

This parameter sets the "Base Level" for energy in the entire model. It is often referred to as the H-BC in this document. Most rivers modeled have only one outflow point and that means there is only one downstream boundary condition point. The program assumes that "1" outflow point is at the downstream of the first segment in the geometric data set; therefore, the control point for the downstream boundary is number one. Therefore, the program will default to that set of logic.

When the distributary option was added, two outflow segments became possible. That requires two H-BC locations. Two variables were established for identifying those downstream boundary control points:

NWSCP = the number of H-BC control points. At this point in time it is either 1 or 2.

IWSCP(j) = the number of the control points having a H-BC

The program defaults to NWSCP = 1 and IWSCP(nwscp) = 1 so all previous data sets can be read without change. A new subroutine was coded to set the control point number for the distributary case. This is Subroutine READDB. It is called from Subroutine BCMOD3 when a \$WSCP-Record is read from the Hydrologic Data Set.

Two options are offered for prescribing the H-BC values. These are

1. Prescribe the water surface elevation on a R-Record for each inflowing water discharge. This is called the WATER SURFACE ELEVATION Option; or
2. Prescribe a water surface vs discharge rating curve relationship. This is called the RATING CURVE option.

**Rating Curve Option.** The rating curve option is identified and the curve(s) is/are read in Subroutine BWMOD4. The curve is stored for use later during the computations. The logic for using the Rating curve option is in that same subroutine.

**Water Surface Elevation Option.** The Water Surface Elevation is read in Subroutine BCMOD3. The value(s) is/are stored in array WSR() and used subsequently from logic in Subroutine BWMOD4.

**Rating Curve Override.** For any event the rating curve value can be replaced at execution time by including the Water Surface Elevation on an R-Record in the Hydrologic Data Set. HEC-6T will not discontinue the Rating Curve option when such an override occurs; it will resume the rating curve option at the next event. **BE CAREFUL OF THIS OVERRIDE. IT IS NOT THE SAME AS THE HEC-6 OPTION AT PRESENT. CONTINUE PLACING R-RECORDS UNTIL IT IS DESIRABLE TO RETURN TO THE RATING CURVE. THEN PLACE A NEW COPY OF THE RATING CURVE.**

**Shift Option.** It is possible to shift all H-BC values by a constant amount. The concept comes from SHIFTING a stage-discharge rating curve as new measurements show a need to change from historical curves.

The shift option is the final H-BC condition processed before computations begin. Therefore, values from both the RATING CURVE and the WATER SURFACE ELEVATION OPTIONS are SHIFTED. The following equation is used.

$$WS(n) = WSCP(i) + SHIFT(i)$$

where

WS(n) = the Starting Water Surface Elevation for the event  
WSCP(i) = the Water Surface Elevation for control point i  
SHIFT(i) = the amount of the Shift at control point i.

Note: Only the external boundaries can have a SHIFT

The SHIFT value is remembered for all subsequent events. To turn off the Shift, enter a S-Record with blank or zero in its proper location in the Hydrologic Data Set.

## Water Yield

Water yield is calculated in Subroutine SRMOD5. It is the total acre feet of water leaving each segment of the network since the run began.

## Examples

Examples of these options are shown in Appendix C, INPUT DATA STRUCTURE.



## 5. NODE TYPES

### Introduction

Having reverse flows on some branches of a network, or having mixed positive and negative water discharges on the same segment when reading them from unsteady flow files, requires logic to delay calculations in portions of a network until junction values have been calculated. Node-type numbers and computation flags are assigned to each cross section to allow that logic to be programmed.

### Sediment Routing Logic

To accommodate positive and negative flows, two concepts were developed for Version 4.0. First, a double sweep technique was designed to process the entire network. On the first sweep, a downstream sweep, positive water discharges are processed. On the second sweep, the reverse flows are processed. Each cross section is assigned a +1 flag at the start of the sediment routing calculations, and after it has been processed the flag is set to 0. After the second sweep, the number of cross sections having a +1 flag is monitored. If one exists, a second pass is made through both the downstream and the upstream sweeps through the network. This process continues up to the number of branches in the network, and if all cross sections have not been processed a **program logic error** is activated. Computations STOP.



## 6. HYDRAULIC CALCULATIONS

### Introduction

The Standard Step Method is used to calculate the water surface profiles. Consequently, the water discharge must be known at each cross section. There are two methods for satisfying that requirement: the water discharge can be prescribed at each inflow point in the network and have the HEC-6T program assign the value to each cross section, or the water discharge can be read from an external file for each cross section. The hydraulic calculations can handle much more complicated networks and flow conditions if the water discharges are known than if HEC-6T must determine the discharges from inflowing boundary conditions.

Version 4 of HEC-6T calculates water surface profiles for only subcritical flow. However, it tests each calculation for the supercritical condition and when supercritical flow is detected, it will calculate the supercritical velocity and its corresponding depth using normal depth theory.

The executive subroutine for Hydraulic Calculations is BWMOD4. That routine reads the Hydrologic Data Set and filters out the Program Commands before performing the hydraulic calculation. The name is only significant in case the computations abort on an error while reading data.

### Flow Direction

Program logic controlling hydraulic computations must detect the flow direction at each cross section. It assumes the geometric model is coded from the downstream to the upstream direction in the Geometric Data file and that all discharges flowing in the downstream direction are coded as positive values in the Hydrologic Data. The program logic then uses the sign of the water discharge in the hydrologic data set to determine the flow direction and invokes a two-sweep procedure to calculate the water surface profiles if necessary.

### Known Water Discharges

The present code will calculate the hydraulic variables for the sedimentation analysis in a network of channels having multiple closed-loop branches and flow conditions provided the flows are known at each cross section. A way to provide those flows is to run an unsteady flow program and save the water discharge hydrographs in an external file. The requirement that the water discharge be known at each cross section can be fulfilled by reading that file of flows. This is the only way to calculate sedimentation in a complicated network of multiple, interconnected-channels; it is the only way to calculate sedimentation in a network where head reversals occur; and it is the only way to calculate sedimentation in a model where flood wave attenuation is dominant as it might be in some reservoir studies. The possible hydraulic conditions that can be evaluated in this fashion are summarized in Table 6.1.

**Normal Backwater Calculations.** The first sweep is the normal upstream sweep of backwater calculations. When all flows are positive in the entire network of channels, only a single upstream sweep is required. However, when mixed flows occur on a branch, the calculations switch between backwater and front-water on SWEEP 1. Therefore, it is important that the network be assembled in the proper order to provide results from one branch before they are needed for calculations in the next branch. This solution is as robust as any backwater solution using

the standard step method.

**Backwater with Reverse (Negative) Flows.** Only one sweep is required, and it starts with the upstream most control point. When only 1 segment is present, negative flow can be prescribed as a boundary condition, and HEC-6T will assign the water discharge to each cross section. However, for reverse flows in a network of channels, the water discharge at each cross section must be read from an external file.

**Front-water.** Using the standard step method for calculating water surface profiles is fine so long as the direction of the sweep is opposite to the direction of the flow. Otherwise, the calculation becomes "Front-water" and the solution is non-convergent.

That means the front water solution will deviate from a backwater solution over the same space. However, in cases of mixed positive and negative flows on a branch, HEC-6T makes a front-water calculation. These mixed flow cases are expected to be rare and to occupy only a small amount of the total space in the network. The front water solution

**Table 6-1. Possible Hydraulic Conditions for Known Flow Distributions**

Case	Flow Condition	Program Response	SWEEP <sup>1</sup>
1	all flows in the network are positive	Normal Backwater Calculation	1
2	all flows in the network are negative	Backwater Calculation with the direction of the sweep reversed	1
3	all flows on a segment are in the same direction, but not all segments in the network are the same	A combination of Cases 1 and 2.	2
4	some flows on a segment are positive and some are negative	Backwater plus Front Water Calculation.	1
5	the network has two outlets	Case 1 flow condition only	1
6	the network has closed loops.	Case 1 flow condition only	

1. SWEEP refers to the number of passes the calculations make through the cross section arrays. A value of 1 means one pass. This will be either from downstream to upstream in direction for normal backwater calculations or from upstream to downstream in networks having all negative flows. A value of 2 means two passes are made. The first is always from downstream to upstream and the second is the reverse.

should be adequate for that situation. Otherwise, this calculation must be inspected very carefully for accuracy. This problem does not apply to solving the sedimentation equations.

**Program Logic for Mixed Flows.** Positive and Negative. If the flow is positive at every cross section on every branch, only one pass through the computation network is made for hydraulic parameters and one for sedimentation. It is in the positive flow-direction. If all flows are negative only one pass is made, and it is in the negative flow-direction. Networks in which some branches have positive and some have negative flows are analyzed in two

sweeps. The special case of positive and negative flows on the same branch is handled with one sweep in hydraulics, and it is the Front-water calculation. It requires at least two sweeps in sedimentation calculations and may require more since the output from one reach becomes the input to the adjoining reach. Therefore, these calculations continue to sweep the network until all cross sections have a sediment solution.

### Unknown Flow Distribution

The most common application of HEC-6T is to read the water discharge boundary conditions for each external boundary around the network and to assign the water discharge to each cross section. In this case HEC-6T can calculate the water discharge and the resulting sedimentation for the hydraulic conditions shown in Table 6-2. This capability to calculate flow distributions, hydraulic parameters and sedimentation in networks with multiple outlets and/or in networks with cutoffs is a very useful feature in the HEC-6T model.

### Closed Loop Hydraulics

When closed loops occur, the flow distribution between the different branches is unknown. This code provides two options for those kinds of networks. One is a distributary option and the other is for one or more interior closed loops. Multiple islands or cutoffs can be present as long as one ends before the next one begins. The solution technique is the same for both, but the details are somewhat different. In the present version of the code, all water discharges in the network must be positive for these calculations to be made. The simplest form of the command is

**Table 6-2. Possible Hydraulic Conditions for UnKnown Flow Distributions**

Case	Flow Condition	Program Response	SWEEP
1	a tree branch system with positive water discharges	Normal Backwater Calculation	1
2	a tree branch system with negative water discharges	Can not calculate	—
3	has one or two outlets with positive water discharges	Backwater Calculation	Iterative <sup>1</sup>
4	has closed loops of not more than two branches each with positive water discharges	Backwater Calculation	"
5	either distributaries or closed loops with negative water discharges	Can not calculate	

1. Iterative means the solution requires successive approximations to converge on a final result and each approximation requires a complete solution through the portion of the network containing the outlets or the loops.

$$E_{i,t} = E_t$$

where

- i = Branch number
- j = The Control Point at the Upstream end of the loop
- QICP(j) = The total water discharge at control point j

The water surface profiles for these two discharges are then calculated. Computations halt at the upstream end of the loop, and the resulting water surface energy line elevations are saved,  $E_{i,1}$  and  $E_{i,2}$

Next, the base and incremental water discharges for Branch  $i+1$  are calculated as follows:

$$Q_{i+1,2} = 1.1 * Q_{i,1} \quad (6-5)$$

The starting water surface elevation for branch  $i+1$  is read from the control point at the downstream end of the closed loop. The water surface profile calculation is made for Branch  $i+1$ , and the resulting energy line values are saved at the upstream junction as  $E_{i,n}$  and  $E_{i+1,n}$ .

To test for convergence,  $E_{i,n}$  and  $E_{i+1,n}$  are substituted into equation 6-7 and compared to the allowable tolerance between the two branches.

$$|E_{i,n} - E_{i+1,n}| < ALER \quad (6-6)$$

where

$$ALER = 0.05 \text{ ft by default}$$

(SEE P-RECORD in the Geometry Data)

If this test passes, the calculation is complete. Otherwise, the trial values from branches  $i$  and  $i+1$  are expressed as straight line equations,  $Q$  versus  $E$ , and the two equations are summed to obtain the equation for  $Q_{TOTAL}$ . The resulting equation is solved for  $E$ . Then the individual branch equations are solved to obtain the branch discharges. A new %OQC<sub>i</sub> value is calculated from the branch discharges. Graphically, the solution is shown in Figure 6.1. The value of OQC is updated after each successful convergence of the flow distribution calculations.

## Prescribed Flow Distribution

A variation of the Closed Loop Option is to prescribe the percentage of flow entering one of the segments and let the computer calculate the percentage entering the other segment followed by the water surface profiles for both segments. The results written to file .T17.

The command for this option is

```
$CL  OQCi  NGDSi  IDWAX
$CL  90     1      2
```

Where:

OQC<sub>i</sub> = The percent of the total flow passing into Branch NGDS = i (i.e. 90%)

NGDS<sub>i</sub> = The Segment Number for branch i = 1

IDWAX = The Option Number for Prescribing the Q = 2

The following variables are written to the \*.T17 file.

```
NCPU  NWSP  NEVNT  I  EGLI  QLI  I+1  EGLI+1  QLOOPI+1  DELEGL
  2      1      1    1  16.49  360000  2      3.30      40000      13.19
```

where

NCPU = Control point number at the confluence of the two outlets.

NWSP = Water surface profile number.

NEVNT = Event number.

I = The stream segment (i) which is the Lower Atchafalaya River in this Example.

EGL<sub>I</sub> = The energy grade line at the junction for segment (i).

I+1 = The next segment number which is Lake Outlet in this Example.

EGL<sub>I+1</sub> = The energy grade line at control point NCPU for segment I+1.

DELEGL = The difference between the two energy lines (EGL<sub>1</sub> - EGL<sub>2</sub>)

The program will write a record for each water surface profile calculation under this header. The file is ASCII.

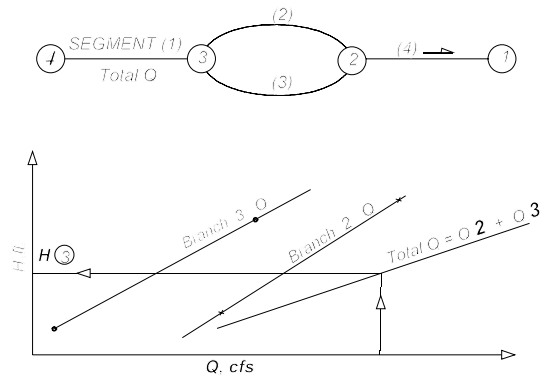

**Figure 6-1. Island Flow Calculation**

## Energy Loss Equations

The energy loss is calculated using average end areas for the area and average of the hydraulic radii at the two successive cross sections for the hydraulic radius of the reach.. In backwater calculations cross section "i" is downstream and cross section "i+1" is upstream. In Front-water calculations it is the opposite. Therefore, the general form of the energy equation is the same for both, but the loss values are added in backwater whereas they are subtracted in front water.

## Hydraulic Parameters for Sediment Calculations

**Hydraulic Parameters.** As the water surface elevation is calculated at a cross section, the velocity, width, depth, slope, n-value, bed shear stress and water discharge for the channel strip will be saved for the sediment calculations. One characteristic of this code is that all sediment calculations are made for the channel strip. Therefore, the channel hydraulic parameters are selected from the total cross section.

**Composite Channel n-Values.** Sediment calculations need a value for each hydraulic parameter the entire channel. There are two options for providing those values. In the first option, the original HEC-6 option, the entire channel cross section is treated as a single unit. Therefore, the program needs no special composite calculations. However, when using the Brownlie or the Limerinos bed roughness predictors, it is important to partition the channel into bed and bank subsections. With this divided-channel option, n-values are calculated for the bed and are assigned to each bank separately. Hydraulic properties for each of these three portions of the channel are calculated separately. Composite option 2 is then suggested to calculate the single value for all hydraulic parameters that is needed in the sediment calculations. (SEE \$K-Record) The following equation is used for Option 2.

$$\bar{n} = \frac{(p_1 n_1^{1.5} + p_2 n_2^{1.5} + \dots + p_N n_N^{1.5})^{2/3}}{P^{2/3}} \quad (6-7)$$

where

N = the last subsection in the channel

$n_n$  = n-value in wet subsection, n

$\bar{n}$  = the composite n-value for the section

$p_n$  = Wetted perimeter in wet subsection, n

P = Total wetted perimeter in cross section

**Slope.** The default procedure is to calculate SLOPE from the energy grade line for all cross sections after the first. Friction slope,  $(Q/K)^2$ , is used for the first cross section. There is an option to use friction slope at every cross section and weight the values by the same numerical coefficients used for velocity, depth and width. However, that option has to be requested. (See Input Description for I5-Record.)

**Velocity.** A special case occurs when flow is supercritical. This code does not calculate supercritical flow profiles; however, it does approximate the supercritical velocity.

**Table 6-3. Printout from Hydraulic Calculations**

A-LEVEL	B-LEVEL
Water Discharge	same as A-LEVEL
Calculated Water Surface Elevation	"
Calculated Total Energy Elevation	"
Alpha Coefficient	"
Water surface width	"
Average Bed Elevation in Channel	"
Velocity in each Strip	"
Percentage of Total Flow in Each Strip	<b>plus:</b>
	Current Cross Section Co-ordinates
	Areas, Hydraulic Radii, n-values, reach lengths by strip at each end of reach
	Effective Velocity, Depth, Width, n-value, and Slope written into the hydraulic parameter arrays, at each cross section, for sedimentation calculations



## 7. SEDIMENTATION CALCULATIONS

### Sediment Inflow

The **first calculation** is the Sediment Inflow Boundary Condition. This is made for each inflow point on each branch of the network. In the original HEC-6 this calculation was made as each segment was reached during the sediment movement calculations. In HEC-6T all sediment inflow boundary conditions are calculated before the sediment movement calculations begin.

### Sedimentation Processes

The **second calculation** is the Sediment movement calculations. They start at the most upstream segment, i.e. the largest segment number, and sweep each segment of the network from upstream to downstream in direction. These computations proceed cross section by cross section, and they end at the smallest cross section number on the smallest segment number.

### Sequence of Calculations

In both the WES Research Version of HEC-6(HAD1) and in HEC-6T negative water discharges are possible. A negative water discharge signifies a flow reversal in which the water is flowing upstream. In the HAD1 code all water discharges in the entire network must be negative if any one is, but in HEC-6T some water discharges may be positive and others negative even on the same segment of the network. When such flow reversals occur in HEC-6T, an upstream sweep for sedimentation processes is made after the downstream sweep is completed.

That is, the cross sections having negative water discharges are skipped on each segment until the entire downstream sweep of the network is completed. The upstream sweep is then initiated and those cross sections having positive flows are skipped on each segment until that entire upstream sweep of the network is completed. During each sweep, HEC-6T is comparing the number of unknowns with the number of equations to ascertain the solution is possible. Each completed cross section is flagged, and the number of cross sections for which sediment movement has been calculated is counted during each sweep of the network. That downstream - upstream - downstream ... sweeping process continues until all cross sections in all segments in the network have been analyzed.

### Hydraulic Parameters

The **third step** is to calculate the numerical values of the hydraulic parameters for the reach. This calculation uses the averaging scheme selected by the I5 card.

### Surface Area

The **fourth step** is to calculate the surface area of the WET-BED in the current reach. This calculation is made in Subroutine BSAREA.

## **New Wet-Bed Weight**

The **fifth step** is adjust the weight in the bed sediment reservoir for the new WET BED. This calculation is made in Subroutine BSRWT.

## **Flow-through Time**

The flow-through time for the reach is calculated next, **step six**.

## **Settling of dredged material**

**Calculation seven** is to determine how much sediment remains in the water column when in-water disposal of dredged material is being used.

## **Local Inflow/Outflow**

The **eighth step** is to test for local inflow/outflow point6891.11.16.8554Tc 0.0022nd(e for the rem)a26 Tdou1(cif any are pd se

$$ENTRLR = \frac{REACH\ LENGTH}{}$$

is the bed shear stress. Two options are provided. The default is Total

### **thirteenth calculation**

#### **Bed Shear Stress**

Boundary Shear using the equation

#### **Silt and Clay Transport**

(7-4)

7-3(7-1)(7-2)

or

$$\frac{C}{C_0} = e^{-k't} \quad (7-5)$$

where

- C = concentration at end of time period
- C<sub>0</sub> = concentration at beginning of time period
- D = water depth
- k' = VsPr/ 2.3D
- Pr = probability that a floc will stick to bed (1 - τ<sub>b</sub>/τ<sub>d</sub>)
- t = time = reach length/flow velocity
- VS = settling velocity of sediment particles
- τ<sub>b</sub> = bed shear stress
- τ<sub>d</sub> = critical bed shear stress for deposition

This ratio is multiplied by the inflowing clay or silt concentration to obtain the transport potential. The concentration is converted to volume and deposited on the bed.

**Cohesive Sediment Erosion**-Erosion is based upon work by Parthenaides (1965) as adapted by Ariathurai and Krone (1976). Particle erosion is determined by:

$$C = \frac{M_1 \cdot S_a}{Q \cdot \gamma} \cdot \left[ \frac{\tau_b}{\tau_s} \right] + C_0 \quad (7-6)$$

where

- C = concentration at end of time period
- C<sub>0</sub> = concentration at beginning of time period
- M<sub>1</sub> = erosion rate for particle scour
- Q = water discharge
- S<sub>a</sub> = surface area exposed to scour
- τ<sub>b</sub> = bed shear stress
- τ<sub>s</sub> = critical bed shear for particle scour
- γ = unit weight of water

As the bed shear stress increases, particle erosion gives way to mass erosion and the erosion rate increases. Because the mass erosion can theoretically be infinite, Ariathurai and Krone (1976) recommended that a "characteristic time," T<sub>e</sub>, be used. With a computation interval of Δt, the mass erosion becomes

$$C = \frac{M_2 \cdot S_a \cdot T_e}{Q \cdot \gamma \cdot \Delta t} + C_0 \quad (7-7)$$

where

$\Delta t$  = duration of time step

$M_2$  = erosion rate for mass erosion

$T_e$  = characteristic time of erosion

Ariathurai and Krone (1976) give guidance on how to obtain or estimate  $T_e$ ,  $M_1$ , and  $M_2$ . Because erosion thresholds and rates for cohesive sediments are dependent on specific sediment particle and ambient water conditions such as mineralogy, sodium adsorption ratio, cation exchange capacity, pH, salinity, and deposition history, in situ and/or laboratory testing are the recommended methods to determine the erosion characteristics of cohesive sediments. A good discussion of cohesive transport is found in Chapter 25 of Shen (1971).

### **Influence of Clay on the Active Layer**

The presence of clay in the streambed can cause the bed's strength to be greater than the shear stress required to move individual particles. This results in limiting the entrainment rate under erosion conditions. HEC-6 attempts to emulate this process by first checking the percentage of clay in the bed. If more than 10% of the bed is composed of clay, the entrainment rate of silts, sands, and gravels is limited to the entrainment rate of the clay. This also prevents the erosion of silts, sands, and gravels before the erosion of clay even if the bed shear is sufficient to erode those particles but not enough to erode the cohesive clay.

### **Mudflow Constraint on Transport Potential**

Because Einstein's concept of the "equilibrium concentration" is utilized for the non-cohesive load, no additional constraints are required to limit the concentrations of sands and gravels. However, when cohesive sediments are included there is no equilibrium concentration. HEC-6T assumes that erosion and entrainment of fines is limited by the "mudflow concentration." HEC-6 and the original version of HEC-6T used the mudflow concentration observed at Mt. St. Helens. Based on two measurements that was 800,000 ppm. The mudflow constraint is still utilized, but the values have been modified as discussed below.

### **Armor Layer Stability**

**Calculation sixteen** is the stability of the armor layer. This calculation uses Gessler's relationship.

### **Equilibrium Depth Calculation**

**Calculation seventeen** is equilibrium depth. It is made in-line in SRMOD5.

### **New Active Layer thickness**

**Calculation eighteen** is the Active Layer calculation which moves sediment between the new active and the old active plus inactive layers.

## Gradation of New Active Layer

**Calculation nineteen** is the gradation for the new Active Layer. It is made in Subroutine BEDPI.

## Transport Potential for Non-Cohesive Sediment

**Calculation twenty** is the transport potential for sand/gravel/cobble/boulder sediments. It utilizes many different subroutines.

## Correction Factor for High Concentration of Fines

**Concentration Equations**-The presentation in this document utilizes the following relationships for the calculation of concentrations and for the conversion between weight and volume units.

$$\gamma_s = S_s \cdot \gamma \quad (7-8)$$

$$V_s = W_s / \gamma_s \quad (7-9)$$

$$C_v = V_s / V \quad (7-10)$$

$$= Q_s / (Q_w \cdot 43.2 \cdot \gamma \cdot S_s) \quad (7-11)$$

$$C_w = W_s / W_t \quad (7-12)$$

$$C_w = C_v G / (1 + (G - 1) \cdot C_v) \quad (7-13)$$

$$C_{ppm} = C_w \cdot 10^6 \text{ (Obsolete)} \quad (7-14)$$

$$C_{mgl} = Q_s / (0.0027 \cdot Q_w) \quad (7-15)$$

$$G = \gamma_s' / \gamma \quad (7-16)$$

$$\gamma_s' = (\gamma_{cl} \cdot C_{vcl} + \gamma_{sl} \cdot C_{vsl} + \gamma_{sa} \cdot C_{vsa}) \quad (7-17)$$

sa refer to categories of clay, silt and sand and larger particles

allows a different specific gravity for clay, silt and sand plus larger particles, and that  
concentration from weight to volume units. First each class of particles must be  
converted to volume units with the following equations:

7:

$$V_{cl} = \frac{Q_{cl}}{(Q_w 43.2 \gamma S_{gcl})} \quad (7-20)$$

$$V_{sl} = \frac{Q_{sl}(L)}{(Q_w 43.2 \gamma S_{gsl})} \Big|_{L=2}^5 \quad (7-21)$$

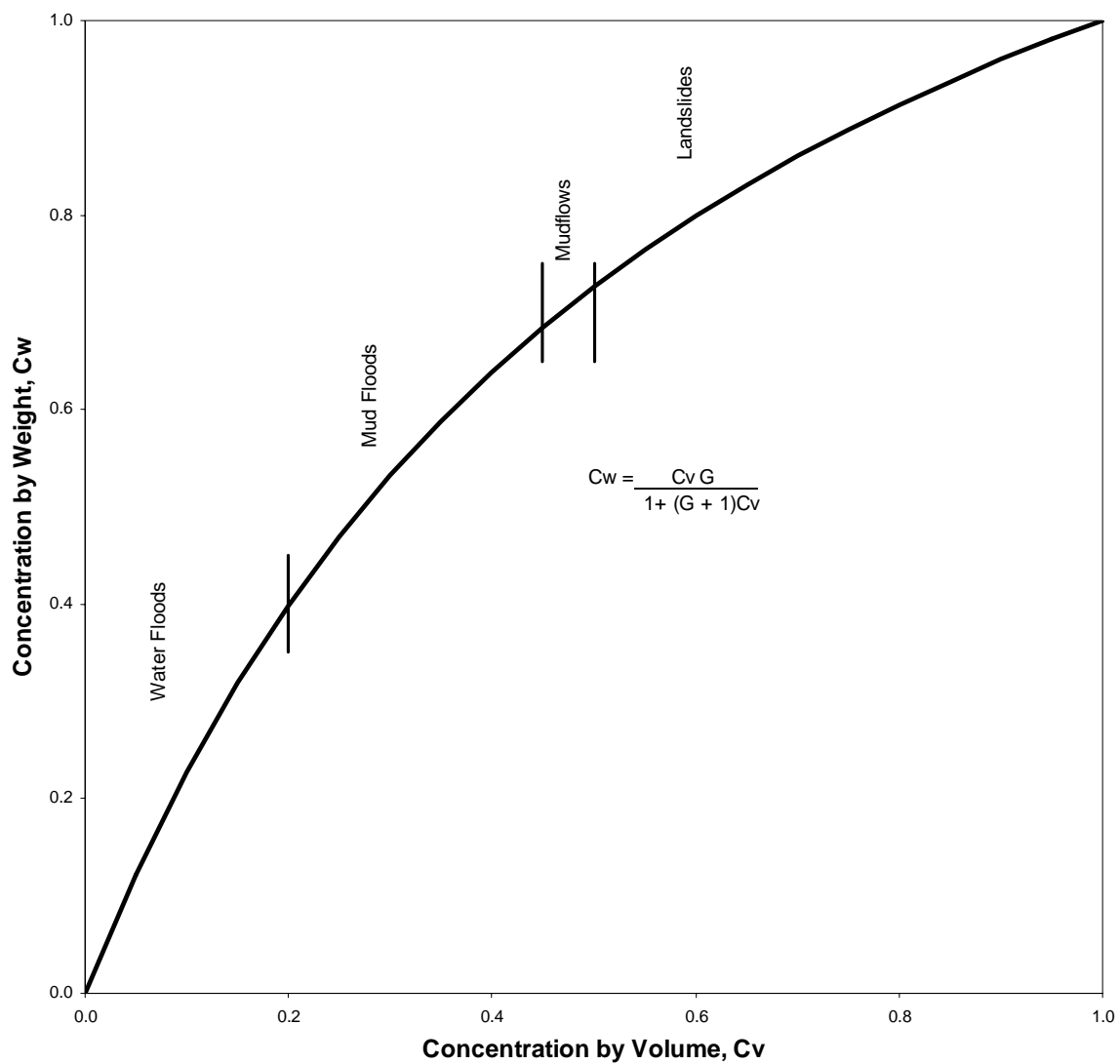

**Figure 7-1. Hyper-concentrated Sediment Flow Classification (After National Research Council 1982)**

These concentrations can be converted into specific weights using equation 7-19. For example, the specific weight of a mixture having a concentration 50 % by volume is calculated as follows:

$$\gamma_m = \gamma_s' \cdot C_v + \gamma (1 - C_v)$$

HEC-6T calculates the specific weight of water as:

$$\begin{aligned} \gamma &= \text{SPGF} \cdot \text{DFW} \cdot \text{ACGR} \\ &= 1.0 \cdot 1.941 \cdot 32.174 \\ &= 62.44973 \end{aligned}$$

where

- C ACCELERATION OF GRAVITY AT SEA LEVEL, 45DEGREES LATITUDE (STANDARD)  
ACGR = 32.174
- C DEFAULT OPTIONS FOR FLUID PROPERTIES
- C STANDARD SPECIFIC GRAVITY OF FRESH WATER AT 4 DEGREES C (39.2 F)  
SPGF = 1.0
- C DENSITY AND SPECIFIC WEIGHT OF FRESH WATER AT 4 DEGREES C  
DFW=1.941

The specific weight of sediment particles is given by

$$\begin{aligned} \gamma_s' &= S_s \cdot \gamma \\ &= 2.65 \cdot 62.44973 \\ &= 165.49 \text{ pounds/cubic foot} \end{aligned}$$

The resulting specific weight of the mixture is

$$\begin{aligned} \gamma_m &= 165.49178 \cdot 0.5 + 62.44973 (1 - 0.5) \\ &= 113.970 \text{ pounds/cubic foot} \end{aligned}$$

The specific gravity of clay, silt, sand and larger particles and the specific weights of the sediment in the bed are prescribed with input data. Default values are given in Appendix F, Record Types I2, I3 and I4. If the specific gravity of all particle types is 2.65, the specific weight of the bed mixture can be expressed as a concentration by volume as follows:

$$C_v = \frac{(UWD / \gamma) - 1.0}{S_s - 1}$$

If the specific weight of sand and larger particles is allowed to default, the value is 93 pounds/cubic foot and the specific gravity is 2.65 (SEE variables UWD and SPGS on the I4-Record). This specific weight can be converted into concentration by volume as follows:

$$C_v = (93 / 62.44973 - 1.0) / 1.65$$

$$= 0.29648$$

The porosity of the bed mixture is volume of voids divided by the total volume expressed as a percent.

$$P_o = 100 \frac{V_v}{V}$$

Since the volume of voids plus the volume of solids is 1, the porosity of the bed mixture, expressed as a decimal, plus the concentration of sediment in the mixture, by volume, must sum to 1. Therefore, the porosity of the default bed mixture is

$$C_v + P_o /$$

$$= 100 (1. - 0.29648)$$

$$= 70.352 \%$$

Because the solution of the sediment continuity equation requires a consistent description of concentrations in the bed and the water column, the limiting concentration in the water column can not be greater than the concentration in the bed.

In normal problems the volume of sediment in the water column is small. However, when the inflowing sediment load is controlled by some mechanism other than an alluvial process, values may not be logical. For example, when the inflow of sediment is from a mining operation it is independent from the inflowing water discharge. One must code the data using the same inflowing load table versus water discharge procedure as is used for alluvial conditions. Consequently, the rate of sediment inflow is prescribed as a constant for all water discharges as shown in the following load table.

LQL Qw	CFS	1	1000
LTL QsT/Day		136000	136000

Obviously, a load of 136,000 tons/day for 1 cfs flow has no physical meaning. The resulting concentration by volume is

$$\begin{aligned}
C_v &= Q_s / (Q_w \cdot 43.2 \cdot 62.44973 \cdot S_s) \\
&= 136000 / (1 \cdot 43.2 \cdot 62.44973 \cdot 2.65) \\
&= 19.
\end{aligned}$$

The program logic is designed to test for such conditions. When a calculated concentration in the water column is greater than  $C_{VMAX}$  the program deposits the excess sediment into the active layer and reduces concentration of the water-sediment mixture to  $C_{VMAX}$ . The entrainment coefficients are then set equal to zero at that cross section which prevents any additional sediment from being entrained from the bed. The following algorithm reduces the concentration of each size class so the total will not exceed the maximum allowable value.

```

C   LIMIT INFLOWING CONCENTRATION BY VOLUME TO CMAXCV (= 0.5)
C   THIS LIMIT IS REQUIRED ONLY UNDER EXTREME CONDITIONS
C   ALL SIZES ARE REDUCED PROPORTIONALLY
C
  IF(CVT .GT. CMAXCV) THEN
    DO L=1,LGS
      CV(L) = CMAXCV * CV(L) / CVT
    ENDDO

    CVCLAY = CMAXCV * CVCLAY / CVT
    CVSILT = CMAXCV * CVSILT / CVT
    CVSAND = CMAXCV * CVSAND / CVT
    CVT = CMAXCV
  ENDIF

```

At the end of the simulation, HEC-6T will print the percentage of time, by cross section, when the very high concentrations occurred. Two threshold values are tested:  $C = 50.000$  mg/l and  $C$  versus  $C_{VMAX}$

Prior to Version 5.13.22 Dated October 31, 2003,  $C_{VMAX}$  was arbitrarily set to  $C_v = 0.5$ . However, this sets the specific weight limit of the mixture in the water column at 113.970 pounds/cubic foot whereas the specific weight of the bed may be only 93 pounds/cubic foot. When sediment deposits from that water volume, the volume of the deposit will be greater than the volume in the water column, and when the volume of a deposit exceeds the end area of flow, a computational warning message is issued. Versions of HEC-6T dated after October 31, 2003, do not permit a concentration in the water column to be larger than the specific weight for the sand and gravel deposits on the I4-Record. If no value is prescribed, the program will use the default value.

Equation 7-19 was re-written to convert specific weight into concentration by volume as follows:

$$C_v = \{(\gamma_m / \gamma) - 1.0\} / (S_s - 1)$$

If the default specific weight is 93 pounds/cubic foot and the specific gravity of the sediment particles is 2.65, the resulting concentration by volume is

$$\begin{aligned}
C_{vbed} &= ((93 / 62.44973) - 1.0) / 1.65 \\
&= 0.29648
\end{aligned}$$

$C_{vlim}$  is set equal to either  $C_{vmax}$  (SEE I6-Record in Appendix F) or  $C_{vbed}$  whichever is smaller. If there are cases

when it is desirable to allow concentrations in excess of 0.29648 by volume the UWD (SEE I4-Record) must be increased. For example, to allow  $C_{vlim}$  to be 0.5, code the UWD of the sand and larger as 113.970 pounds/cubic foot.

Notice that the conversion equation does not mention size class. As long as the specific gravity of all particles is the same, i.e. clay, silt, sand, gravel, cobbles etc, the above equation will convert the mixture into concentration by volume. However, if different size particles have different specific gravities, HEC-6T will not perform the correct conversion.

There may be occasions when the calculated concentration of sediment discharge exceeds  $C_{vlim}$  and remains there for a significant percentage of the simulation time. HEC-6T will run and will make the calculations. However, the characteristics of a non-Newtonian fluid are not modeled in this code. According to Figure 7-1 the transition from a Newtonian fluid to a Bingham fluid occurs between concentrations of 0.2 and 0.45 by volume. Such a limitation does not mean that useful information can not be extracted from the calculated results, but the interpretation must be made with care.

## **Sediment Outflow from Reach**

**Calculation twenty-three** solves the Exner equation for the new sediment rate out of the reach and for the new bed source values.

## **New Active Layer Gradation**

**Calculation twenty-four** determines the new gradation of the surface of the new bed sediment reservoir.

## **Trap efficiency**

After sediment movement calculations are complete for all branches in the network, the program makes a trap efficiency calculation if that option was selected. That is, if print out were requested.

In HEC-6T a two-sweep procedure is used for trap efficiency. Two arrays are defined - one for inflow and the other for outflow. SWEEP #1 is the U/S to D/S sweep for positive Q. In that case inflow is at the U/S end and outflow the D/S. SWEEP #2 is performed when there are negative flows. In that case inflow occurs at the downstream end and outflow at the U/S. Consequently, trap efficiency for the downstream sweep may be different from that for the upstream sweep for the same branch.

## **Bed Change-Sediment Movement**

The next activity in Subroutine SRMOD5 prints the new bed change, the thalweg profiles and the sediment discharge passing each cross section. This printout is requested on the \*-Record of the Hydrologic Data Set.

## **Residence time**

The time in days required for the water to flow through each segment of the network is the final calculation in Subroutine SRMOD5. When these values are shorter than the computation time step, the results are acceptable. When these values are significantly longer than the computation time step, there is a numerical dispersion in the results. Inspect the results for reasonableness before accepting the values.

## 8. BED ELEVATION CALCULATIONS

### Bed elevation changes

Bed change calculations are made after the sedimentation processes have been calculated for the reach. Version 5.13 provides two options for changing the cross section elevations: Option 1 and Option 3. Do not use Option 2.

Option 1 changes all bed elevations a uniform amount subject to the following constraints:

- the elevation is within the movable bed limits (i.e. the Bed Sediment Reservoir), and
- the elevation is wet.

Option 1 is based on the assumption that the hydraulic forces which shaped the initial cross section will continue to dominate the alluvial processes. Consequently, as the end area of a cross section changes in response to sedimentation processes, the shape of the cross section will remain similar to its original shape. This assumption is appropriate for perennial streams which are reasonably close to regime. However, in the channel of a perennial stream which is undergoing major regime changes or in an ephemeral channel which typically demonstrates a flat bottom after each event, this assumption is not well founded.

Option 3 limits the width of deposition to the dredged channel. If no dredged template is prescribed, the program uses Option 1.

These options are selected by placing a **\$GR-Record** in Hydrologic Data Set as described in the appendix “Special Commands and Program Options” in this manual. The Default option needs no **\$GR-Record**. However, it is sometimes desirable to switch from Option 3 to Option 1.

### Deposition and Erosion Limits

Setting deposition and erosional limits are described in Chapter 2, Geometric Data. Bed changes are calculated similarly in each case.

### Smoothing Cross Section Elevations

The bed change calculation in the HEC-6T program was developed for large rivers in which bed changes were gradual and hydrographs rose and fell slowly with respect to time. In the small channels where the model is being applied today, the bed often fluctuates wildly during the passing of a hydrograph. Sometimes sediment will deposit during the peak flows and then erode during subsequent low flows. Since there are no checks on slope stability, the bed can become very irregular as shown in Figure 8-1. This is not a bridge cross section. It is a normal channel section which has become distorted by extreme bed changes during the passing of a hydrograph.



$$dydxl(i,j) = \frac{y(i+1) - y(i)}{x(i+1) - x(i)}$$

(8-1)(8-2)

$$DYDX = \frac{(Y(I+1) - Y(I))}{X(I+1) - X(I)}$$

The equation for YITMP in the *BACKWARD SWEEP* is

$$YITMP = YIT(I+1) - DYDXL(I,J) \cdot (X(I+1) - X(I)) \quad (8-4)$$

If  $YITMP < Y(I)$  in either sweep, then smoothing is performed by replacing the existing elevation,  $Y(I)$ , with  $YITMP$ . Neither the cross section stations nor the limiting slopes in array  $dydxl(i,j)$  are changed during a simulation.

**Limiting Slopes.** As geometry is read, the initial values of cross section slopes are calculated. The assumption is these values are stable for the cross section, and some will be greater than the angle of repose of sand. These slopes are saved in array  $DYDXL(i,j)$  for use later during the simulation in the test for the **limiting** cross sectional slopes. The program passes through the limiting slope calculations only one time. All subsequent passes through this subroutine will skip over this calculation of the limiting slope.

Note the smoothing calculation is restricted to the movable bed portion of the cross section. The cross section station where the movable bed starts is at array index  $ISM$ , and the station where it stops is at  $IFM$ .

**Two Foot Test.** Even though the smoothing option is on, the program will not smooth a cross section until the difference between two adjacent cross section elevations becomes more than 2-feet. This constraint comes from field observations in which near vertical cuts exist when the depth is shallow. Shallow is a relative term, and two feet is arbitrary. However, the constraint allows the model to mimic observed conditions for vertical cuts when the depth is small.

If the difference between adjacent elevations becomes more than 2 feet, a second test is made in which the elevations are compared with the allowable slopes in the  $DYDXL()$  array. A forward pass is made, and a backward pass is made across each cross section. These passes are in SECTION 5 of the subroutine.

**Mass Conservation.** If any elevations are smoothed, it is necessary to correct all elevations within the smoothed portion of that cross section so mass will be conserved. This calculation is made in section 6 of the subroutine.

**Trace Printout.** To check the calculations, turn on a C-Level trace in Sediment printout. The cross section stations and elevations will be printed before and after smoothing. These outputs are made as the calculations proceed, and they end by printing the final coordinates as shown below.

**Smoothing Command.** Smoothing is turned off by default. If smoothing is desired, place a **\$SMOOTH**-Record at the beginning of the HYDROLOGIC Data set. The following example illustrates a placement. The command can be placed anywhere a COMMAND RECORD is permitted. Smoothing can be turned on or off when the user desires.

The command in the following example turns smoothing ON and sets the interval after each computation

event, (i.e. the 1 following the ON sets the smoothing interval). When the interval is omitted, the program defaults to 100 water surface profiles.

**Example.**

```

$HYD
$SMOOTH      ON      1
$RATING      1
RC           6      200      100      1.37      1.84      2.01      2.16
2.28
RC           2.39
*   AB      RUN 1
Q   1000
T    55
W    1
.
.
.
$END

```

**Change in Average Bed Elevation**

The HEC-6 model prints the accumulated bed change for the channel portion of the cross section in the SB-2 Table of the model printout. The calculation is made in two steps. When the initial cross sections are read from the input data file, the initial average bed elevation is calculated. Then, each time during the simulation hydrograph that the SB-2 printout is requested, the current value of the average channel bed elevation is calculated. The initial value is subtracted from the current value to provide the accumulated change in channel bed elevation to that point in time in the simulation hydrograph.

**Approach.** The channel is defined by the left and right top bank stations on the X1-Record. The average bed elevation is calculated between those stations. The approach is to determine the highest elevation in the channel,  $Y_{max}$ , and to use that elevation as the reference plain for calculating the cross sectional end area and the channel width. The average bed elevation in the channel is then calculated below that reference plain using the hydraulic depth equation:

$$AVGBC = YMAX - \frac{BEDAR}{BEDWI} \quad (8-5)$$

where

BEDAR = the cross sectional area below the reference elevation, YMAX

BEDWI = top width of the cross section at elevation = YMAX

YMAX = the reference elevation is the highest bed elevation within the channel portion of the cross section

AVGBC = the average bed elevation

**Initial Average Bed Elevation.** The initial AVERAGE BED ELEVATION is calculated when the geometry input data are read. One value is calculated for each cross section and saved in array BEDELI ( i ). This value is not changed during the simulation.

**Change in Average Bed Elevation.** When printout is requested for the sedimentation calculations, the average bed elevation is calculated for current geometry. The change in average bed elevation, DYACC, is calculated by subtracting the initial average bed elevation from the current value as follows

$$DYACC = AVGBC (ASN (NXSA) , YMAX , LCHL (NXSA) , LCHR (NXSA) ) - BEDELI (NXSA)$$

## 9. DREDGING

### Introduction

Dredging can be requested after any event in the Hydrograph by inserting a **\$DREDGE** command. (See Appendix H, Special Commands & Program Options). The program will then dredge at every cross section at which the dredging option was prescribed in the geometric data set (See the H\*-Record sets in Appendix E, Geometry and Channel Properties). It can be stopped by inserting a **\$NODRED**

### Dredging Options

Two dredging options are provided. The first is called a fixed *template option*. The fixed template is when the dredging template is prescribed by a bottom elevation, a starting station and an ending station. When the bed elevation becomes higher than the template bottom, dredging is performed.

The second dredging option is called the *vessel draft option*. This is where the width of the dredged channel is prescribed by a starting station and an ending station, but dredging is triggered when the water depth at the cross section becomes less than the required draft for navigation.

The different options cannot be mixed in a single model run. All segments in the model must use the same option.

### Dredging Sites

Each segment can be partitioned into dredging sites. The basic code allows up to ten different sites, but different versions of the code allow for a different number of dredging sites. Check the "Program Dimensions Table," which is printed immediately after the Banner in the printout file, for the allowable number of dredging sites in your version of code.

Each dredging site can have a different dredging rate. The prescription of dredging rates is described with the (**\$DREDGE, DF, DC**)-Records.

Dredging quantities are calculated by event and summed for the entire length of the hydrograph.

**Establishing Dredging Sites with H or HD-Records.** The original option for prescribing dredging used **H** - or **HD-Records**. Those records are still processed by the program. If there is only one dredging site, the **H** - and **HD-Records** are adequate. However, **HI** or **HL-Records** are required to prescribe more than one dredging site.

**Establishing Dredging site with HI or HL-Records.** The **HL-Record** option for prescribing dredging allows up to 9 dredging sites. Site numbers are read from Field 9. The NDRR array is the dredging logic flag. For no dredging NDRR() is zero. At each cross section in a dredging site, NDRR is set equal to the Dredging Site number. When dredging is completed at a cross section, the sign of NDRR is set to negative. Each cross section having a negative NDRR is then skipped until the next **\$DREDGE**-Record in the input data file is read. The NDRR value is

printed in the DR-1 Table of dredging volumes. Values change from positive to negative as each reach is finished.

## Dredging Rates

Dredging can be performed instantly; or it can be performed at rates prescribed in cubic yards per day. Each dredging site can have a different rate.

## Example

Dredging is requested by placing the program command **\$DREDGE** in the hydrological data set. The dredging rate option is prescribed on a **DC-Record** which is placed immediately after the **\$DREDGE**-Record as shown in figure 9-1. One DC-Record is needed for each dredging site. It shows site number, disposal type and dredging capacity. The units for dredging capacity are cubic yards per day. In the following example, the first DC-Record is for site number 1. It requests disposal method 1 and prescribes a dredging capacity of 1000 cubic yards per day.

Figure 9-1. Example input data set for dredging.

```
$HYD
*      B  RUN 1
Q 10000
R      10
T      45      45
W      1
$DREDGE
DC      1      1      1000
DC      2      2      5000
DC      3      2      100
DC      4      1      100
DC      5      2      5000
DC      6      2      5000
DC      7      2      100000
*      B  RUN 2
Q 10000
W      1
$PLOTP      8,9
$$END
```

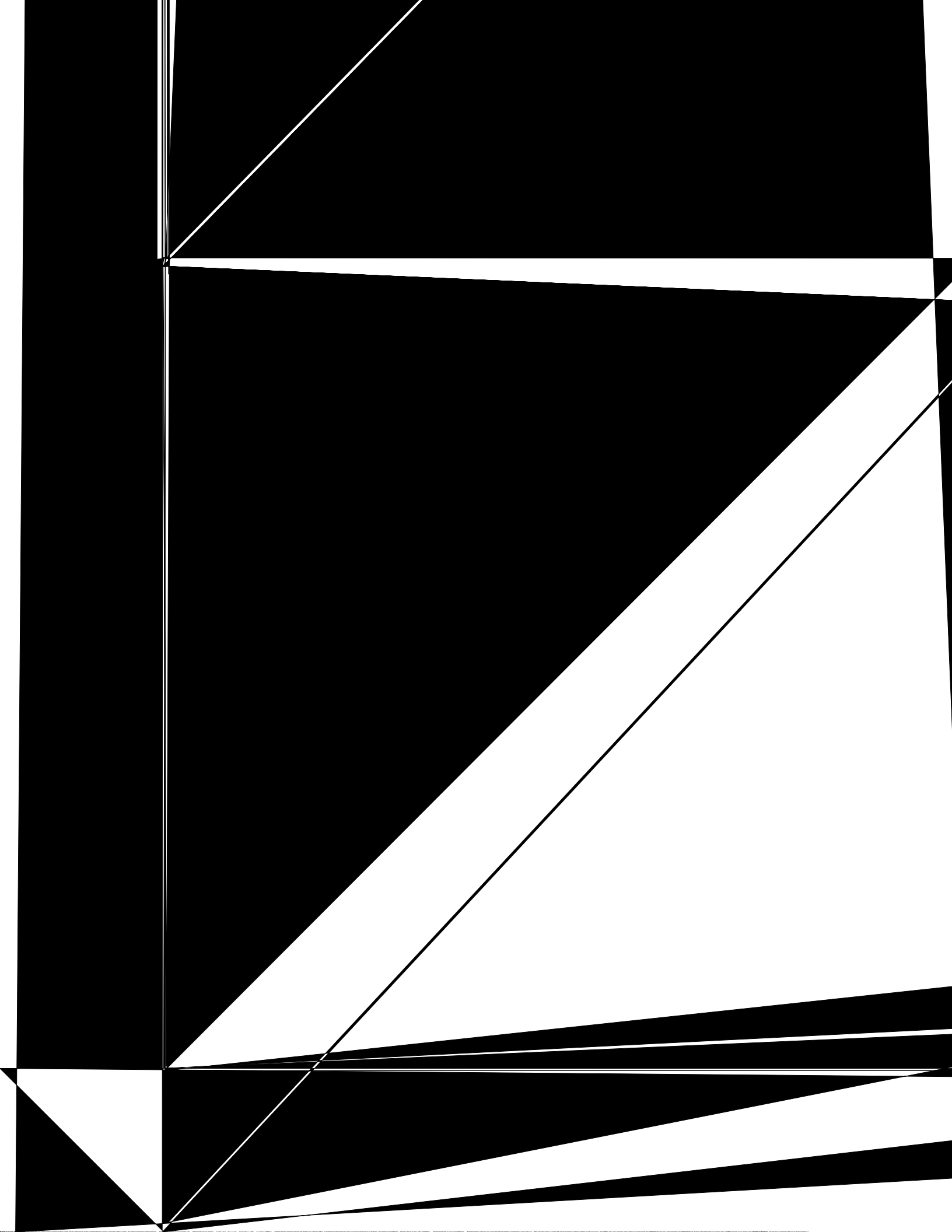

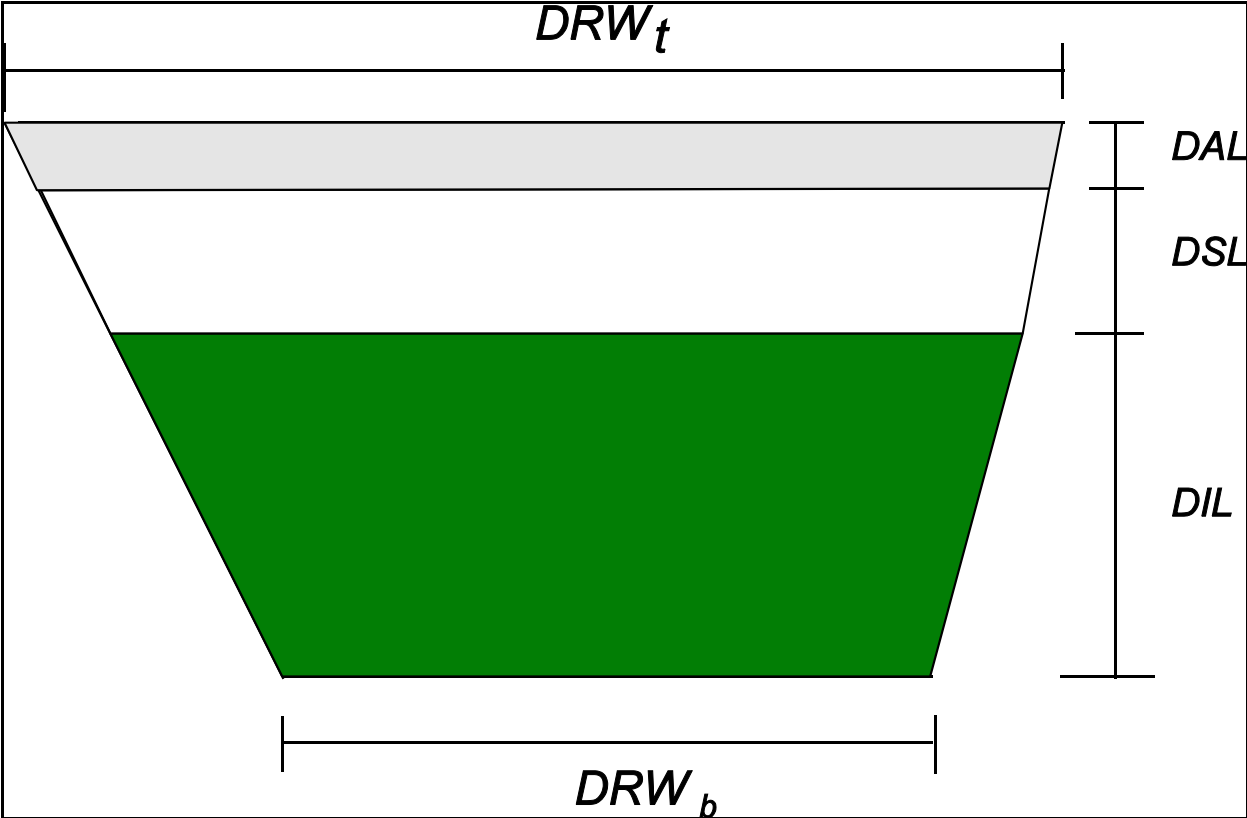

Figure 9-2. Layers in the Dredged Section

The total depth of the dredged cut is

$$h_d = DAL + DSL + DIL \quad (9-3)$$

Top and bottom widths are determined by the spacing of cross section coordinates on the GR-Records. The equation for the width of the dredged channel at depth DAL is

$$DWDAL = DRW_t - DRWDH \cdot (DAL) \quad (9-4)$$

where DRWDH is defined as

$$DRWDH = \frac{(DRW_t - DRW_b)}{DRH_d} \quad (9-5)$$

$$DRW_t = X(IFD+1) - X(ISD-1) \quad (9-6)$$

$$DRW_b = X(IFD) - X(ISD) \quad (9-7)$$

where

DAL	=	depth of Active Layer
DRWDH	=	change in width with respect to dredging depth
DRW <sub>b</sub>	=	Bottom width of dredged channel
DRH <sub>d</sub>	=	Total depth of dredged channel
DRW <sub>t</sub>	=	Top width of dredged channel
ISD	=	Cross Section Station to start dredging
IFD	=	Cross Section Station to stop dredging

This equation is applied to the Subsurface Layer - Inactive Layer interface by replacing the DAL variable with DAL + DSL.

## **Dredged Material Disposal**

The original HEC-6 offered no options for disposal of dredged material. The material was disposed outside of the model limits. This version of the code offers that method, but in addition, dredged material can be disposed back into the water column. There are two options at this time:

Option 1 places the dredged material back into the water column at the first cross section downstream of the current dredging cross section.

Option 2 places the dredged material back into the water column at the first cross section downstream from the current dredging site.

Only one of these options may be selected for a dredging site. Each dredging site can have a different option.

When the dredging site starts with cross section number 1 in a segment, there is no downstream reach in which to place the dredged material. In that case, it is placed outside of the model limits.

## **Sediment Deposition in the Dredged Reach**

There are rivers which are dredged every year but the cross section outside of the dredged template never aggrades. These situations indicate that the significant deposition occurs within the lateral limits of the dredged template. A coding option is provided to allow the model to mimic such situations. It is Option 3 on the \$GR Command Record. The current version of HEC-6T, Version 5.13, treats all dredging locations the same. That is, it is not possible to apply Option 3 to some dredging reaches and not to others. However, when no dredging template is present in the cross section, the code automatically defaults to Option 1 for that cross section.

## 10. MBH GRAPHICS

### Introduction

Producing a graph is a 2 step process.

Step 1: Place a \$PLOT-P-Record in the HEC-6T Hydrologic Data Set where the plot is desired and run the HEC-6T simulation. The program will write a ".T98" file with the input file name for that run.

Step 2: Second, go to windows and double click the Mobile Boundary Plotter icon. When the "PLOT SORT" window appears OPEN the desired .T98 file and select the frames to be plotted. The details are explained in this chapter.

### The \$PLOT Command

The parameters which can be plotted are shown in Table 10-1 and in Appendix H, Program Commands. Parameters are selected on the \$PLOT[P]-Record. All plots which are selected are written to the plot file, as the values exist in the computation arrays, when the PLOT-Record is read in the input file.

The \$Plot command instructs the program to write output files in DSS form. Attach a P to the plot command, \$PLOT-P, and additional plotting parameters will be added that cannot be read into DSS but can be plotted with MBH graphics.

The available plots are listed in the Table 10-1.

Table 10-1. Available Plots

Option Number	Plot	Description of Plot
1	Total Water Discharge	This is a profile of the Total Water Discharge at each cross section versus Channel Station. This plot is made from the SB-2 Table, Column 5.
2	Channel Discharge	This is a profile of water discharge in the channel at each cross section versus Channel Station. This is a calculated value for which there is no printout.
3	Top Width	This is a profile of total water surface width at each cross section versus Channel Station. Values are displayed in the HA- tables, Hydraulic Printout, under the heading TOP WIDTH.

Option Number	Plot	Description of Plot
4	Average Bed Elevation	<p>This is a profile of the average elevation of the channel bed at each cross section versus Channel Station Values are calculated by subtracting the hydraulic depth from the water surface.</p> <p>In a 3-subsection model the average bed elevation for the plot is the same as the value printed in the HA-1 Table under column heading AVG BED ELEV.</p> <p>In a 5-subsection model the same equations are used, but the average bed calculation for the plot uses only the channel bed subsection - not the banks of the channel. Therefore, the calculated plot will usually be different from the Average Bed values in the hydraulics printout.</p>
5	Slope	Slope of the Energy Line used in the sediment computations. This value will be either the change in total energy or $(Q/K)^2$ depending on the slope option selected on the I5-Record. It is plotted versus Channel Station. Values are displayed in the B-Level printout, Hydraulic Calculations.
6	Channel Velocity	This is a profile of the water velocity used in the sediment computations. This will be the Water Velocity in the Channel subsection plotted versus Channel Station. Values are displayed in the B-Level printout, Hydraulic Calculations.
7	Channel n-Value	This is a profile of the Manning n-Value used in the sediment computations. It will be the Channel n-value plotted versus Channel Station. Values are displayed in the B-Level printout, Hydraulic Calculations.
8	Water Surface Elevation	This is the water surface profile.
9	Bed Surface Elevation	This is the thalweg profile. Values are displayed in the SB-2 Table in the Sedimentation Calculations.
10	Effective Width	This is a profile of the width used in the sediment computations. It will be the Effective Width of the Channel subsection plotted versus Channel Station. Values are displayed in the B-Level printout, Hydraulic Calculations.
11	Effective Depth	This is a profile of the depth used in the sediment computations. It will be the Effective Depth of the Channel subsection plotted versus Channel Station. Values are displayed in the B-Level printout, Hydraulic Calculations.
12	<del>Sand Discharge Rate</del>	Not available at this time
13	<del>Silt Discharge Rate</del>	Not available at this time
14	<del>Clay Discharge Rate</del>	Not available at this time

Option Number	Plot	Description of Plot
15	X-Section Coordinates	Plot of cross sections. When using the \$PLOT option, the subsection boundaries, conveyance limits, limits of the bed sediment reservoir and erosion limits are plotted as symbols on the cross section.
16	X-Sections with WS Elev	The water surface elevation is added to the graph of option 15.
17	Top Bank Profiles	Profiles of the elevations of both the left and right channel banks are plotted versus Channel Station. There is no printout showing these values.
18	Accumulated Volume Profiles	The \$VOL command with an X-option calculates reservoir area-capacity tables. This is plot option to produce a profile of the accumulated volume versus cross section. Only the first elevation in a table of elevations will be plotted.
19	Accumulated Surface Area Profs	The companion to option 18.
20	Total Clay Inflow, Tons	<p>A profile of total weight of the inflowing clay load is plotted versus channel station. This profile has units of tons of clay versus channel station. The total weight is accumulated from the beginning of the hydrograph to the point in the input data file where the \$PLOT-Record(s) appears.</p> <p>This plot is made from the VOL-1 Table, Column 5, lines marked as INFLOW.</p>
21	Accumulated Clay Delivery, Tons	<p>A profile of the total weight of clay transported past each cross section in the model. The Total Clay Inflow of option 20 and the Accumulated Clay Delivery, at any cross section, can be plugged into the equation for trap efficiency. The result is the model trap efficiency upstream from that point.</p> <p>This plot is made from the VOL-1 Table, Column 5. All lines except INFLOW are the calculated clay movement and are plotted.</p>
22	Total Silt Inflow, Tons	<p>A profile of total weight of the inflowing silt load is plotted versus channel station. This profile has units of tons of silt versus channel station. The total weight is accumulated from the beginning of the hydrograph to the point in the input data file where the \$PLOT-Record(s) appears.</p> <p>This plot is made from the VOL-1 Table, Column 4, lines marked as INFLOW.</p>

Option Number	Plot	Description of Plot
23	Accumulated Silt Delivery, Tons	<p>A profile of the total weight of silt transported past each cross section in the model. The Total Silt Inflow of option 20 and the Accumulated Silt Delivery, at any cross section, can be plugged into the equation for trap efficiency. The result is the model trap efficiency upstream from that point.</p> <p>This plot is made from the VOL-1 Table, Column 4. All lines except INFLOW are the calculated clay movement and are plotted.</p>
24	Total Sand Inflow, Tons	<p>A profile of total weight of the inflowing sand and larger load is plotted versus channel station. This profile has units of tons of sand and larger versus channel station. The total weight is accumulated from the beginning of the hydrograph to the point in the input data file where the \$PLOT-Record(s) appears.</p> <p>This plot is made from the VOL-1 Table, Column 3, lines marked as INFLOW.</p>
25	Accumulated Sand Delivery, Tons	<p>This is a profile of the total weight of sand and larger transported past each cross section in the model plotted versus channel station. The Total Sand and larger Inflow of option 20 and the Accumulated Sand and larger Delivery, at any cross section, can be plugged into the equation for trap efficiency. The result is the model trap efficiency upstream from that point.</p> <p>This plot is made from the VOL-1 Table, Column 3. All lines except INFLOW are the calculated clay movement and are plotted.</p>
26	Accumulated Dep/Er, CY	<p>This is a profile of the calculated volume of deposition or erosion plotted versus channel station. The value is calculated from the sediment load passing each cross section and not from changes in the cross section elevations.</p> <p>This plot is made from the VOL-1 Table, Column 7.</p>
27	Change in Average Bed Elevation	<p>The calculated change in the average elevation of the bed sediment reservoir. This plot is made from the SB-2 Table, Column 2.</p>
28	Max/Min Q Profiles	<p>If the \$MXMN option is selected the program detects the maximum discharge and the minimum discharge, at each cross section, during the run. The results can be plotted versus channel station with this option. SEE Appendix H, Special Commands and Program Options for the \$MXMN option.</p>
29	Max/Min WS Elevations	<p>Same as Option 28 except water surface is plotted.</p>
30	Max/Min Bed Elevations	<p>Same as Option 28 except bed surface is plotted.</p>
31	Max/Min Sed Discharge	<p>Same as Option 28 except total sediment discharge is plotted.</p>
32	Max/Min Sed Conc	<p>Same as Option 28 except total sediment concentration is plotted.</p>

```

Example:          FIELDS
1234567 1234567 1234567 1234567 1234567 1234567 1234567 1234567
1234567
$HYD
$PLOT TITLE = "HOTOPHIA CREEK, 1977" 9,15
*
Q
R
T
W
*
...

```

The PLOT-Record is read with a free field format. It must contain the word TITLE (ALL CAPS) for the code to expect a titling string. Put the titling string in ". The title can be up to 20 Characters. Separate the plot types with a comma or a blank. Both Title and Plot types can be changed within the run. When placed as above, the first plot will show the initial BED profile and the cross sections in the model.

## Making Screen and Hard Copies with MBH-PLOTTER

Go to windows and double click the Mobile Boundary Plotter icon. The *PLOT-SORT* screen, shown in Figure 10-1, will appear.

**Opening a Plot file.** The sedimentation program writes the plot frames to TAPE98, but any file name can be attached to this plotter program.

Click on the menu item **File** and then click on **Open** and the name of the last file plotted will be displayed in the *File Name* window of the *OPEN* screen. To change files, select the drive, directory and file name using standard Windows procedures. Only the file name is required if the *Directories* text box shows the correct path name.

**Plotting all frames.** To view all graphs (frames) in the plot file click the PLOT button on the MBH Plotter screen. Graphs are viewed in the Graph Display screen. To return to the MBH Plotter screen use the CLOSE option in the CONTROL menu.

**Selecting the Plot Frame.** Figure 10-2 shows the *MBH Plotter* screen with the path and filename of the working file across the top. The plot frame headers are displayed in the top window of this screen, labeled as the HEADER WINDOW. To select a plot frame, highlight its header record and click on the **GROUP** button. The header record will appear in the *Plot Frames Window*, Figure 10-3, followed by the word PLOT. Click on the **PLOT** button between the Header Window and Plot Frames Windows to view the graph. For example, the screen image for a plot of the Water Surface and Bed Surface Profiles is shown in Figure 10-4.

Sometimes it is more expedient to select plot frames by first clicking the PLOT button as if to plot all frames and then returning to the MBH Plotter Screen where the delete option can be used to remove the unnecessary graphs. To return from the Graph Display screen to the Plotter Screen use the CLOSE option in the CONTROL menu.

**Over plots.** To overblow two frames, go to the *MBH PLOTTER* screen, highlight both header records and click on the **GROUP** command button. Click on **PLOT** and view the frames as above. The base and up to 4 over plots can be made.

**Legend.** To optimize screen size the legend was placed in a drop down list. Click on the **LEGEND** Button, and it

will expand showing the legend box.

**Printing all Plots.** To send all selected plots to the printer, click on the **FILE** menu button and the **Print All** option on the *GRAPH DISPLAY* screen.

**NOTE: Before Printing be sure to change the printer attributes so that it will print in Landscape. Reprinting the first graph may be required if this is not done upon entering the program.**

**Printing a Single Plot.** To print a single frame, click on the **PLOT** command button on the *MBH PLOTTER* screen and select the plot by clicking on the <<LAST NEXT >> options at the top of the *GRAPH DISPLAY* screen. When the desired frame is in view, click on the **Control** menu button and select the **Print** submenu. From the **Print** Submenu choose *Print This Plot*.

**Linking Segments Together.** To link frames together, highlight their header records and click on **LINK** . The plot numbers separated by a + sign indicates which are linked. View as described above. Notice that a **PLOT** command is placed in the *Plot* window each time the **GROUP** or **LINK** command button is clicked. To overblow frames which have been linked together, Click the "PLOT" command between the two and then click the **DELETE** command button.

**Deleting Plot Frame.** To delete plots from the *Plot* Window, high light the desired lines and press the **DELETE** key on the keyboard.

### **Saving Plot Commands.**

A command file is formed as plot frames are selected. This file can be saved for reuse by returning to the MBH Plotter Window and clicking on the "SAVE AS" option in the FILE menu. Assign the extension .pcf to the file name and the program will display the possible plot command files in subsequent runs when the Plot Command option is selected.

### **Attaching an Existing Plot Command File.**

First OPEN the plot file (i.e. the .T98 file). Then from the FILE menu click on the Plot Command option. The screen will display all .pcf files and prompt for the name of the plot command file to attach.

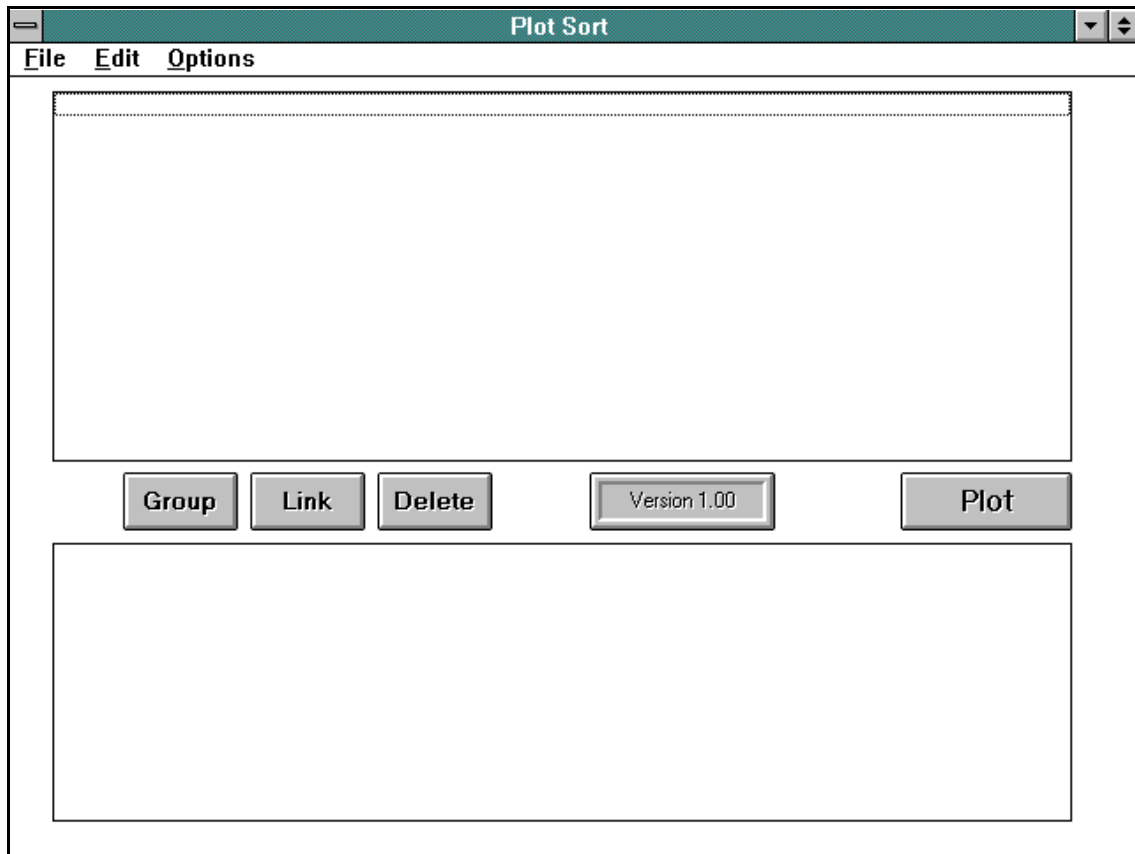

Figure 10-1. Plot-Sort screen

HEADER  
WINDOW

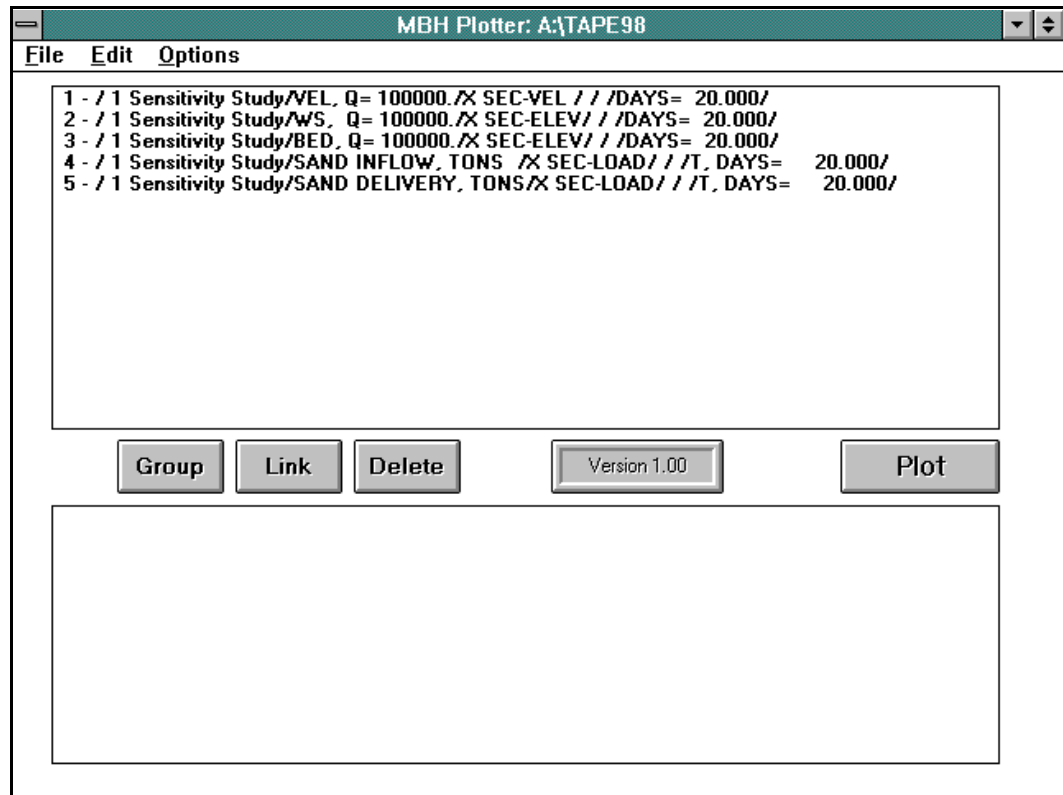

Figure 10-2. MBH Plotter screen showing header records for plot frames

HEADER  
WINDOW

PLOT  
FRAMES  
WINDOW

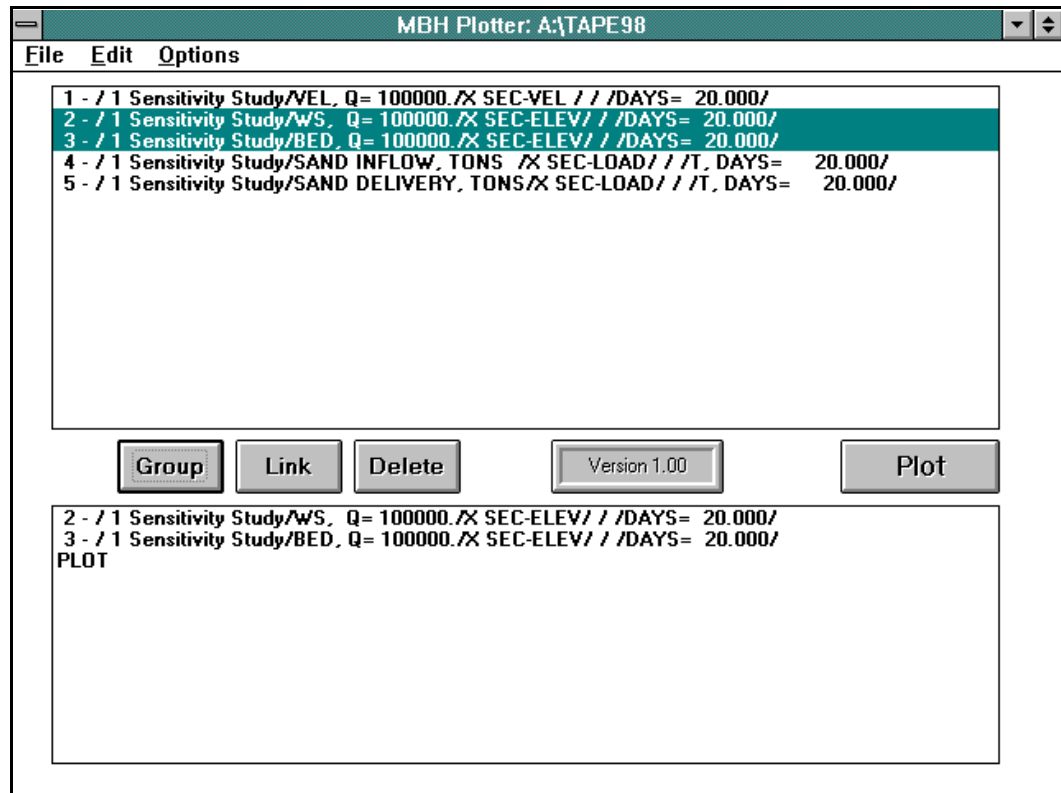

Figure 10-3. MBH Plotter screen showing selected headers after a group

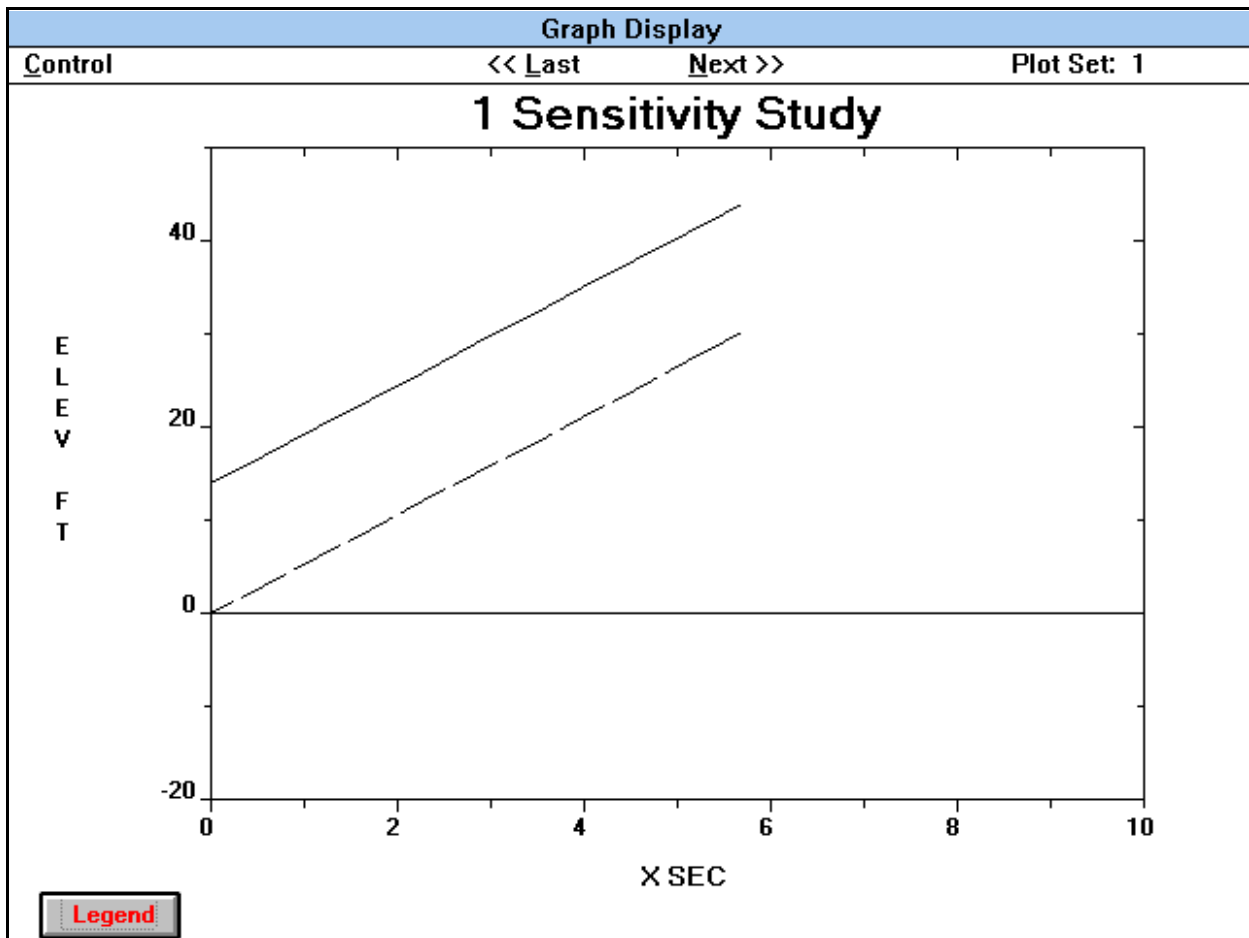

Figure 10-4. The Graph Display screen showing a Bed Surface Profile with the Water Surface Profile over plotted

# 11. ERROR AND DIAGNOSTIC MESSAGES

## Error and Diagnostic Message Numbers

Error and Diagnostic message numbers are 5 digits long. For example, error number **30101** is assigned when the reach length is missing on a P- or PX-Record.

Each error number is composed of three parts: The first digit is Error Type:

1 = Information Message	Sets the INFO Flag
2 = Warning Message	Sets the MAGO Flag
3 = Fatal Error	Sets the NOGO Flag

The second plus third digit identify the Program Activity Category. For example, "01" is reading and processing the geometric input data set.

The final two digits are error number. Error and diagnostic messages are shown in the Table 11-1.

When the program finds an error it prints information to the .T6 file. In the case above, ERROR NUMBER 30101, the following message is printed

```
INPUT DATA***HEC6 FATAL ERROR      30101
**MAIN PROGRAM**
P?-RECORD..EXTEND MODEL, BUT REACH LENGTH IS MISSING.(SEE P- OR
PX-RECORD)
```

In this case the error is fatal. The NOGO flag is incremented to allow the data file to be read before aborting the run. The NOGO feature allows the program to check the entire geometry file for errors before aborting.

## Status of Diagnostic and Error Messages

This feature is subject to change as new messages are added. Not all messages printed to the .T6 file are included in this chapter.

Table 11-1. Error and Diagnostic Messages

Sub Program				Error	
Number	Name	Category	Purpose	Number	Description
3	GMOD	1	Processing Cross Section Controls and Strip Boundaries	10101	STST (X3- OR B-RECORD) IS LESS THAN THE FIRST X-SEC STATION (GR-1). IT WAS ADJUSTED
	GMOD	1		10102	ENST IS GREATER THAN THE LAST CROSS SECTION STATION. IT WAS ADJUSTED.
	GMOD	1		10103	THE ELEVATION DIFFERENCE BETWEEN X-COORDINATES ___ AND ___ IS LARGE. ELEVS.=
	READMB	8	Read and Process Bed Sediment Reservoir Dimensions	10801	H -RECORD..CROSS SECTION STATION TO START THE MOVABLE BED IS CONSTRAINED BY THE STST ON THE XL-RECORD.
	READMB	8		10802	H -RECORD..CROSS SECTION STATION TO END THE MOVABLE BED IS CONSTRAINED BY THE ENST ON THE XL-RECORD.
	STREDI	20	Reading and Processing Sedimentary Input Data	12001	READING SILT DATA FROM I3-RECORD. PROGRAM EXPECTS EROSION SHEAR STRESS TO BE GREATER THAN DEPOSITION SHEAR STRESS. IT IS NOT CODED THAT WAY FOR LAYER TYPE ____ . DEPOSITION THRESHOLD = ___ EROSION THRESHOLD = ___
	STREDI	20	Reading and Processing Sedimentary Input Data	12001	The program has compared the Specific Weight of the Bed Deposit, UWD on I4-Record with the extremely high Concentration Flags, SEE I6-Record, and found an abnormal condition. The hyper-concentration flag for the suspended sediment mixture is greater than the specific weight of the bed deposit. Check for possible error on I4-Record or I6-Record.

Sub Program				Error	
Number	Name	Category	Purpose	Number	Description
	Loop	56	Island Flow Calculation	15601	The calculated EGL for Q+DelQ is lower than the EGL for Q. This trial is not used for balancing the flow distribution. Reducing ALER may improve convergence. (See ALER on [P,PX]-Record in User's Manual)
	BANKST	1		20102	DID NOT FIND A X-SEC PANEL THAT MET THE CRITERIA FOR A BANK. I.E. A SIDE SLOPE OF ___::1V' SEE XB-RECORD.
	READMB	8		20801	DREDGED CHANNEL REQUESTED AT GR STA _____ IT CAN NOT START BEFORE THE MOVABLE BED _____ (Note: Program assigns first movable point in cross section.)
	READMB	8		20802	DREDGED CHANNEL REQUESTED AT GR STA _____ IT MUST STOP AT THE LIMIT OF MOVABLE BED _____ (Note: Program assigns last movable point in cross section.)
	AVGBC	11	Calculate average change in bed elevation	21101	AVERAGE BED ELEVATION = ___
11	STMOD2	20	Reading and Processing Sedimentary Input Data	22001	LOCAL SEDIMENT INFLOW TABLES: SEGMENT NO. ___ PROGRAM HAS READ ENOUGH SEDIMENT LOAD TABLES TO SATISFY THE INFLOW/OUTFLOW POINTS ON THIS SEGMENT AND THE NEXT RECORD IS: ___
	STMOD2	20		22002	LOCAL SEDIMENT INFLOW TABLES: SEGMENT NO. ___ THERE ARE NO LOCAL INFLOW/OUTFLOW POINTS ON THIS SEGMENT BUT DATA FILE CONTAINS A \$LOCAL DATA SET STARTING WITH THE FOLLOWING.
	BCMOD3	30	Reading and Processing Hydrologic Boundary Conditions Input Data	23001	INPUT DATA ERROR ON THIS RECORD. EVENT NUMBER ___
	BCMOD3	30		23002	ATTEMPTING TO READ PAST END OF INPUT DATA, FINAL RECORD IN INPUT DATA FILE WAS NOT \$\$END. PROGRAM RAN TO END OF HYDROLOGIC DATA AND TERMINATED. EVENT NUMBER ___

Sub Program				Error	
Number	Name	Category	Purpose	Number	Description
	BWMOD4	40	Executive Routine for Controlling Hydraulic (Backwater) Calculations	24001	A CLOSED LOOP WITH A LOCAL INFLOW HAS A FLOW REVERSAL. THATS NOT PERMITTED. SEGMENT#, LOCAL INFLOW POINT#: __ __
	BWMOD4	40		24002	CLOSED LOOP FLOW DISTRIBUTION FAILED TO CONVERGE. ITERATIONS CODE= __. CONTROL POINT NO= __ SEGMENT NOS= __ QTOTAL = _____ EGL1= __ EGL2= __
	BWMOD4	40		24003	ATTEMPTING TO READ PAST END OF INPUT DATA. FINAL RECORD IN INPUT DATA FILE WAS NOT \$\$END. PROGRAM RAN TO END OF HYDROLOGIC DATA AND TERMINATED. EVENT NUMBER __)
	BWCMD5	41	Reading and Processing Program Commands	24101	PROGRAM EXPECTS *- OR \$-RECORD BUT DOES NOT RECOGNIZE NEXT RECORD.
	PRSELX	41		24102	REQUESTED CROSS SECTION NOT IN MODEL. _____
	READSC	41		24103	HEC-6T READ A \$BASIN RECORD BUT NO CP-RECORD. IT ASSIGNED THE DEFAULT CONTROL POINT NUMBER. __ AND SEGMENT NUMBER= _
	BASINH	50	Calculate Flood Wave Attenuation and Change in Basin Water Surface	25001	MUST CODE THE ZONE NUMBER ON HC & HX RECORDS _____
	HARDYX	55		25502	CONV WAS RESET BECAUSE IT BECAME .LT. 0.
21	ENDJOB	90	End of Job Processing	29001	DREDGING IS NOT COMPLETE. MUST EXTEND THE HYDROGRAPH TO SEE FINAL VOLUMES.
1	AATABS1	01	Read Geometric Input Data	30101	P?-RECORD..EXTEND MODEL, BUT REACH LENGTH IS MISSING.(SEE P-OR PX-RECORD)
	AATABS1	1		30102	CANNOT EXTEND MODEL YET. READ AT LEAST ONE CROSS SECTION TO ESTABLISH A TEMPLATE.

Sub Program				Error	
Number	Name	Category	Purpose	Number	Description
	AATABS1	1		30103	XB RECORD HAS FEWER THAN 5 STATIONS AT CROSS SECTION
	AATABS1	1		30104	STREAM SEGMENT # = ',I3,' CROSS SECTION # = ',I4,/ A HYDRAULIC CONTROL IS REQUESTED BY THE X5-RECORD AT CROSS SECTION ',F10.3,/ ' MODEL MUST HAVE AT LEAST 2 CROSS SECTIONS IN A CONTROL VOLUME.
	AATABS1	1		30105	THE FOLLOWING RECORD IS NOT USED IN HEC-6T
	AATABS1	1		30106	ALL X-SECS ON A SEGMENT MUST BE THE SAME... EITHER WITH OR W/O XB-RECORDS'
	AATABS1	1		30107	REACH LENGTH IS MISSING-- SEE X1 OR XC-CARD
	AATABS1	1		30108	n-VALUE IS MISSING... STRIP NO. =
2	DATDIG	1	Error Diagnostics for Geometric Data	30110	PROGRAM EXPECTS ___ -RECORD BUT FOUND FOLLOWING:
	AATABS1	1		30109	CONVEYANCE LIMIT OR START/END STATION ERROR AT CROSS SECTION = ____ THIS XSEC MAY NOT HAVE CORRECT NO OF COORDINATES. LEFT CONVEYANCE LIMIT= RIGHT CONVEYANCE LIMIT=
	MAPNET	1		30111	THE LOCAL INFLOW POINT AT CROSS SECTION = ___ ON SEGMENT _ IS PRESCRIBED WITH A QL-RECORD LINKING THAT INFLOW POINT WITH OUTFLOW POINT NUMBER ___ ON SEGMENT ___. POINT NO ___ IS NOT OUTFLOW ON THAT SEGMENT.
	GMOD	1		30112	RIGHT CHANNEL STATION = ____ > LAST GR-STATION. = ____
	GMOD	1		30113	CHANNEL STATIONS DO NOT INCREASE IN MAGNITUDE
	GMOD	1		30114	X-COORDINATE IS SMALLER THAN THE PREVIOUS ONE
	GMOD	1		30115	CHECK SUBSECTION STATIONS. PROGRAM COULD NOT ASSIGN LSS(NSS+1)
	BANKST	1		30117	PROGRAM IS LOOKING FOR BANK SLOPES >= 5H::1V, A CROSS SECTION MUST HAVE AT LEAST 4 COORDINATE POINTS BETWEEN LEFT AND RIGHT TOP BANK.

Sub Program				Error	
Number	Name	Category	Purpose	Number	Description
	READGR	1		30118	VALUES CODED ON FOLLOWING GR-RECORD ____ CODE EXPECTS AN EVEN NUMBER. BLANK IS NOT READ AS 0. IT IS SKIPPED.
	READGR	1		30119	SEGMENT ____ CROSS SECTION ____ HAS ____ DATA POINTS. MAX ALLOWABLE IS ____
	READGR	1		30120	READING FOLLOWING RECORD.
	READHR	1		30121	HEC-6T FOUND TOO MANY NH-RECORDS AFTER CHANNEL STATION ____
	READHR	1		30122	HEC-6T FOUND FEWER NH-RECORDS THAN NUMNH SAID ON NH-RECORD AFTER CHANNEL STATION ____
	READHR	1		30123	STATIONS ON NH-RECORDS CAN NOT DECREASE.
	READQL	1		30124	THIS STYLE OF CLOSED LOOP JUNCTION WILL NOT RUN. RE-FORM THIS DATA FOR VERSION 4.00 NETWORK MODEL.
	READQL	1		30125	READING GEOMETRIC DATA AND LOCAL INFLOW COMES D/S FROM THE FIRST CROSS SECTION ON SEGMENT
	READQL	1		30126	QP-RECORD IS FOR OUTFLOWS ONLY. CHANGE % TO A NEGATIVE VALUE.
	READQL	1		30127	SEGMENT NUMBER ON THE QL-RECORD CANNOT BE NEGATIVE.
	READQL	1		30128	INFLOW/OUTFLOW POINT NUMBER ON THE QL-RECORD CANNOT BE NEGATIVE.
	READMB	8	Read and Process Geometric Data for Dimensions of Bed Sediment Reservoir	30801	PROCESSING H_-RECORD DATA. THE GR-STATION TO START DREDGING COMES BEFORE THE STST-STATION FOR THIS CROSS SECTION GR-STATION, XSDR, TO START DREDGING (H_-7). = _____ STST STATION FROM XL-RECORD (XL-6). = _____
	READMB	8		30802	PROCESSING H_-RECORD DATA. THE GR-STATION TO STOP DREDGING', COMES AFTER THE ENST-STATION FOR THIS CROSS SECTION', GR-STATION, XFDR, TO STOP DREDGING (H_-8). = _____ ENST STATION FROM XL-RECORD (XL-7). = _____
	READMB	8		30803	H-RECORD IS REQUIRED WITH LRD FORMAT.
	READMB	8		30804	CANNOT SKIP A X-SEC WITHOUT CHANGING THE DREDGING SITE NO. (SEE H*-RECORDS) X-SECS = ____

Sub Program				Error	
Number	Name	Category	Purpose	Number	Description
	STMOD2	20	Reading and Processing Sedimentary Input Data	32001	DATA ERROR ON FOLLOWING RECORD
	STMOD2	20		32003	PROBLEM TOO BIG FOR GD(ARRAY)
	STMOD2	20		32004	PROBLEM TOO BIG FOR CAR(ARRAY)
	STREDI	20		32005	READING CLAY DATA FROM I2-RECORD. PROGRAM EXPECTS EROSION SHEAR STRESS TO BE GREATER THAN DEPOSITION SHEAR STRESS. IT IS NOT CODED THAT WAY FOR LAYER TYPE ____ . DEPOSITION THRESHOLD = __ EROSION THRESHOLD = __
	STREDI	20		32006	READING CLAY DATA FROM I2-RECORD. PROGRAM EXPECTS MASS EROSION SHEAR STRESS TO BE GREATER THAN PARTICLE EROSION SHEAR STRESS. IT IS NOT CODED THAT WAY FOR LAYER TYPE ____ . PARTICLE EROSION THRESHOLD= __ MASS EROSION THRESHOLD = __
	READN	20		32007	DATA ERROR ON FOLLOWING RECORD
	READSD	20		32008	SUBROUTINE READSD DOES NOT RECOGNIZE THE FOLLOWING RECORD.
		20		32009	ERROR IN CODING SD RECORD. SEE INPUT DESCRIPTION.
	READIX	20		32010	DATA ERROR ON FOLLOWING IX-RECORD. ____ PLEASE CHECK IX RECORD IN USERs MANUAL.
	READIX	20		32011	READ TO END OF DATA ON FOLLOWING IX-RECORD. ____ PLEASE CHECK SEDIMENTARY DATA IN USERs MANUAL.
14	BCMOD3	30	Reading and Processing Hydrologic Boundary Conditions Input Data	33001	PROGRAM EXPECTING Q-RECORD AND FOUND FOLLOWING.
	BCMOD3	30		33002	Q MUST START IN FIELD 1. EVENT NO _____ Q _____
	BCMOD3	30		33003	TOO MANY DISCHARGES ON Q-CARD. MAX NO = ____ EVENT NO ____ Q = _____

Sub Program				Error	
Number	Name	Category	Purpose	Number	Description
	BCMOD3	30		33004	WATER TEMPERATURE IS OUT OF RANGE. NGDS= _____ NXS = ____ WT( ) _____
	BCMOD3	30		33005	ERROR.. PLEASE ADD WATER TEMPERATURE RECORDS TO THE HYDROLOGIC DATA FILE.
	BCMOD3	30		33006	ACCUMULATED DAYS ON X-RECORD MUST BE GREATER THAN CURRENT TOTAL IN RUN. X RECORD, FIELD-1 = ____ CURRENT TOTAL IN DATA SET = ____
	BCMOD3	30		33007	TIME NOT CODED CORRECTLY ON FOLLOWING RECORD. SEE HYDROLOGIC DATA IN MANUAL. _____
	BCMOD3	30		33008	THE COMPUTATION TIME STEP IS _____ DAYS AT EVENT NO. ____
	FILLQ2	30		33009	HEC6T CAN NOT SOLVE THE LOCALS AS PRESCRIBED IN THIS NETWROK.
	BWCMD5	41	Reading and Processing Program Commands	34104	RECIRCULATION OPTION: X-SEC # __ NOT ON SEGMENT
	BWCMD5	41		34105	THE FOLLOWING LP-RECORD IS FOR A SEDIMENT TABLE WHICH IS NOT IN THIS MODEL
	BWCMD5	41		34106	\$CL-RECORD REQUESTED SEGMENT NUMBER IT IS NOT IN THIS MODEL.
	BWCMD5	41		34107	REQUESTED ZONE NO __ EXCEEDS MODEL DIMENSIONS
	BWCMD5	41		34108	CONTROL POINT OUT OF RANGE ON FOLLOWING OC-RECORD. PROGRAM READ CONTROL POINT = ____
	BWCMD5	41		34109	OUTFLOW DISTRIBUTION COEFFICIENTS DO NOT SUM TO 100% CONTROL SEGMENT COEFFICIENT POINT NO NO. (QC-VALUE %)
	BWCMD5	41		34110	PROGRAM DOES NOT RECOGNIZE FOLLOWING OPTION.
	BWCMD5	41		34111	NOT ENOUGH SPACE TO SAVE MAXIMUM AND MINIMUM VALUES. STORAGE AVAILABLE IN GD(ARRAY) = ____ STORAGE REQUIRED FOR THIS MODEL= ____ A RESTART FILE WAS WRITTEN: FILE_NAME = _____

Sub Program				Error	
Number	Name	Category	Purpose	Number	Description
	BWCMD5	41		34113	ATTEMPTING TO READ PAST END OF INPUT DATA, EVENT # ___
	BWCMD5	41		34115	THE SEGMENT NUMBER ON THE FOLLOWING LP-RECORD IS NOT THIS MODEL DATA.'
	READUQ	41		34117	PROGRAM EXPECTS W- OR X-RECORD BUT READ _____
	READUQ	41		34118	ERROR IN READING UNET INPUT. READ TO END OF FILE
	READEX	41		34119	THE EXNER OPTION REQUESTED ON THE FOLLOWING CARD IS NOT AVAILABLE. PLEASE CHECK ..PROGRAM COMMANDS.. IN USERs MANUAL.
	READT12	41		34120	THE TAPE12 OPTION REQUESTED ON THE FOLLOWING CARD IS NOT AVAILABLE.
20	READSC	41		34125	ERROR IN CONTROL POINT NUMBER. \$BASIN RECORD: NCP = ___
	READSC	41		34126	ERROR IN CONTROL POINT NUMBER. \$BASIN RECORD: NGDS = ____
	READSC	41		34127	SEGMENT ___ THE OUTFLOW CROSS SECTION IS ABOVE THE INFLOW CROSS SECTION! CHECK FIELDS 3 & 4 BELOW.
	READSC	41		34128	BASIN NUMBER ___ THE NUMBER OF WATER DISCHARGES SHOULD BE BETWEEN 1 AND ___ ! CHECK FIELD 2 BELOW
	BASINH	50	Calculate Flood Wave Attenuation and Change in Pool Elevation	35001	INPUT DATA MUST BE CODED IN VERSION 4.+ FORM FOR THE \$BASIN OPTION. SEE \$SEG RECORD IN GEOMETRIC DATA SET.
	BASINH	50		35002	ERROR IN CONTROL POINT NUMBER. \$BASIN RECORD: NCP = ___
	BASINH	50		35003	ERROR IN SEGMENT NUMBER. \$BASIN RECORD: NGDS = ___
	BASINH	50		35004	BASIN NUMBER ___, THE NUMBER OF WATER DISCHARGES SHOULD BE BETWEEN 1 AND ___ ! CHECK FIELD 2 BELOW
	BASINH	50		35005	COMPUTER READING HYDROLOGIC DATA AND CAN NOT READ THE FOLLOWING DATA RECORD.

Sub Program				Error	
Number	Name	Category	Purpose	Number	Description
	BASINH	50		35006	BASINH: SURFACE AREA = 0. EL1SC(NSC)= ___ EL2SC(NSC)= ___ MINIMUM ELEV IN BASIN= ___
	ENDJOB	90	End of Job Processing	39001	TO PLOT SEDIMENT INFLOW AND DELIVERY, PLACE THE \$VOL RECORD AFTER THE PLOT REQUEST AS FOLLOWS: \$PLOT [20,21,22,23,24,25,26] \$VOL





**APPENDIX A**

**REFERENCES**



## Appendix A

### **REFERENCES**

Chow, Ven Te. 1959. "Open-Channel Hydraulics," McGraw-Hill, New York.

Shen, Hsieh Wen. 1971. Ed, River Mechanics. Water Resources Pub., Littleton, CO.

U.S. Army Corps of Engineers. August 1993. "Scour and Deposition in Rivers and Reservoirs (HEC-6)," User's Manual. Hydrologic Engineering Center, 609 Second Street, Davis, CA.



## **APPENDIX B**

### **DESCRIPTION OF VARIABLES**



## Appendix B

### DESCRIPTION OF VARIABLES

AAK	=	Local, Scalar. The end area of the cross section in the Erosion/Deposition portion of the cross section. (Subroutine NEWGR) SEE EAK, AAS, and EAS
AAS	=	Local, Scalar. The end area of the cross section in the Deposition only portion of the cross section. (Subroutine NEWGR) SEE AAK, AAS, and EAS
ACGR	=	Global Scalar. The acceleration of gravity used for current job. Defaults to the standard acceleration of gravity which is 32.174 Feet/Second/Second at 45 Degrees latitude at sea level.
ACOEFO	=	Global;
ACTIV	=	Local, Scalar. Active layer weight by grain size.
ADAY	=	Accumulated time of the run in DAYS.
ADMIX	=	Global, Scalar. Allowable distance for mixing when a local or Tributary enters.
AI	=	Global Array. Accumulated time in days.
ALDMNT	=	Global, Scalar.
ALE	=	Global, Array. Active Layer Elevation.
ALER	=	Global, Scalar Maximum allowable error between trial and computed water surface elevation.
ALFA	=	Global, Scalar. Coriolis coefficient.
ALTMX	=	Global, Scalar.
AMASS(i,n)	=	COMPUTATIONAL ARRAY, Global, Accumulated Weight of Sediment at each cross section n for each particle size i.
AMASSI(i,l)	=	COMPUTATIONAL ARRAY, Global, Accumulated Weight of Sediment Outflow from Control Point l to the Segment for particle sizes i.
AMASSL(i,j,k)	=	COMPUTATIONAL ARRAY, Global, Accumulated Weight of Sediment at each Local Inflow/Outflow Point j on Segment k for each particle size i.
AMASST(I,L)	=	COMPUTATIONAL ARRAY, Global, Accumulated Weight of Sediment at each Tributary Junction I for each particle size i.
AS10	=	Accumulated sediment inflow summed for all entry points on the control volume boundary.
ASEL	=	Global, Scalar. Average slope of the energy line. Used to predict the first trial WS in the first Backwater Calculation.

ASISG()= Global, Array, Accumulated volume of sediment entering a segment. Usually from the upstream direction; however, when flow is negative it will be from the downstream direction. Used in trape efficiency calculations.

ASLSG() = Global, Array, Accumulated volume of sediment entering a segment from the lateral direction. Used in trape efficiency calculations.

ASN() = Global, Array. Storage for AVGS.

ASOSG() = Global, Array, Accumulated volume of sediment leaving a segment. Usually in the downstream direction; however, when flow is negative it will be in the upstream direction. Used in trape efficiency calculations.

AVGK = Global, Scalar. Average conveyance for the reach.

AVGS = Global, Scalar. Average cross-section identification (river-mile) for printout.

BCOEF = Global, Array.

BE = Bottom elevation of dredged channel.

BEDSWC(L,I) = Global; Weight by size Class (i.e. clay, very fine silt, fine silt ...etc... large boulders), of the BED source which is deposited into the Storage portion of the cross section during the solution of the EXNER equation. Maximum size of L is the maximum number of grain sizes in the model.

BEDSOK() = Local; Calculated mass of Bed Source term (gmi-gpr)\*RTOK, by particle size, in deposition/erosion portion of cross section.

BEDSOR = Local; Computation variable for the bed source term (gmi-gpr). It is re-used for each particle size.

BEDSWT(N,I) = Global, Total Weight of the Bed source which is deposited into the Storage portion of the cross section during the solution of the EXNER equation. The array is by size class group (i.e. clay, silt, sand+gravel+cobbles+boulders). Maximum value of N = 3.

BLOOP(L) = Calculation Array, Global; The solution of the closed loop problem requires two straight lines. The general form of the equations is  $y = mX + B$ . BLOOP is the "B" Coefficient in that solution. (SEE XMLOOP)

BSAE = B coefficient in equation  $FSAE = A*SAE*B*SAE$ . \00/

CAR = Global, Array. The primary coefficient array for sediment data. This is a vector array for several different types of data as follows.

CAR(1) = SPI.

CAR(2) = UWD.

CAR(3) = UWW.

CAR(4) = SUK.

CAR(5) = BSAE.

CAR(6) = IBG.

CAR(K5) = Global; Coefficient array - total weight of all size fractions in the current inactive bed, CAR(KFIA), at this cross section.

CAR(KFIA) = Global; Coefficient array - weight of each size class in the current inactive bed at this cross section.

CAR(NVR+2\*NR+3\*(NSAND+1)+ILQ), [I=1-to-NGS+1]) = Log Base-e of Inflowing Sediment Discharge by Particle Size (tons/day) , Main Stem Inflow. (NAQ is Locator).

CAR(NVS+(NGS+4)\*NR+3\*(NSAND+1)+I\*LQT(NTEP)), [I=1 -to- (NGS+1)]) for each trib)) = Tons of Sediment in Bed Sediment Reservoir by Particle Size Class.

CAR(NVS+2\*NR+3\*(NSAND+1)+LQ\*(NGS+1)+I), [I=1-to-NR]) = Width of Movable Bed. (NYV is Locator).

CAR(NVS+2\*NR+3\*NSND+NSAND\*I), [I=1-to-3]) = Curve-Fit Coefficients for n-value correction, for use in MTC is 2 (I4-2).

CAR(NVS+2\*NVR+NR\*I), [I=1-to-3]) = Curve-Fit Coefficients of Depth\*Slope vs GP(i) for MTC is 2 (I4-2).

CAR(NVS+3\*NR+3\*(NSAND+1)+LQ\*(NGS+1)), [I=1-to-NR]) = Tons of Sediment in Bed Sediment Reservoir by Particle Size Class (NIS is Locator).

CAR(NVS+I), [I=1-to-NR]) = Volume Shape Factor (VSF).

CAR(NVS+NR+I, [I=1-to-NR]) = Initial depth of Sediment in Bed Sediment Reservoir.(Locator is NGR).

CC = Global, Scalar. Coefficient of contraction.

CCA(NXSA) = STORAGE ARRAY, Global, Coefficient of Contraction at each Cross section.

CCCD = Global, Scalar.

CCCL = Coefficient in the equation for rate of compaction of clay deposits.

CD = Global, Array.

CDTEMP = Dummy variable to simplify discharge coefficient computations.

CE = Global, Scalar. Coefficient of expansion.

CEA() = Global, Coefficient of Expansion at each Cross section.

CF = Global, Array. Coefficient of free flow for weir equation.

CFCM = Global, Scalar.

CHNGE = Global , Array.

CHNGM = Global, Array.

CHST = Global, Scalar. Cross section station at right side of main channel.

CL() = Global, Used by Toffalieti to pass parameters.

CLAERO = Global, Array.

CLAUWT = Global, Array.

CLBK = Global, Scalar. Critical depth water surface.

CLC = Conveyance Limit Centered; The width of conveyance in feet. This is an option for setting left and right side limits for conveyance. The program will center it midway between the left channel station and the right channel station.

CLDTCL = Global, Array.

CLE = Global , Array.

CLL = Global, Scalar. Conveyance Limit Left; The first cross section station to include in the end-area, wetted-perimeter, and conveyance. computations.

CLR = Global, Scalar. Conveyance Limit Right: The last cross section to include in the end-area, wetted-perimeter, conveyance computations.

CLUSSM = Global, Array.

CMUD = Global , Scalar.

COEF = Global, Array. COEFFicients for free and submerged flow over wiers or energy loss at bridges.

CONCWC(IL) = Array, Global, Tons of Sediment dredged at site "I" by size class "L".

COR = Correction of transport capacity for N-vlaue; User supplied transport function.

COUNT= Global, Scalar. COUNTs the Number of trials required in the trial and error computations for water surface profiles.

COVER(MXNGS+1) = Global; The number of layers of particles in the bed surface layer. One layer has a thickness of 2\*Particle Diameter. Each size class has a different thickness. Cover is the accumulation of all size classes.

COVERI = Coverage, Inactive Layer; regional variable; The number of layers of sediment in the inactive layer. See COVER for explanation of a layer.

CPAR = Global, Scalar. Either elevation or discharge for entering the a n-value versus Elevation or Q table.

CRL = Constant Reach Length.

CRLATS( ) = Global; The lateral storage array for the inactive layer (i.e. the CAR() values of bed sediment.)

CRT = Global, Scalar. Critical section factor when testing for critical depth; after Chow.

CWCA = Global, Scalar. Consolidated weight of clay.

CWS = Global, Scalar. Computed water surface elevation for most recent trial.

CWS1 = Global, Scalar. Computed water surface elevation from a previous trial.

CWSA = Global, Scalar. ?????

CYV = Coefficient of depth to end area.

D2 = Diameter of grains just larger than required to armor the bed (figure 8-9).

D84() = Global, The particle size for which 84% is finer by weight.

DAL = Local, Scaler; In Dredging Calculations it is the Depth of the Active Layer. In SRMOD5 it is the Actual (EFFECTIVE) Depth of the Water.

DAL1 = Depth of Active Layer, local Variable;.

DASH = Global, Scalar.

DAXIS() = Global; Diameter Axis when reading PF-Records.

DBI = Global; Weighting coefficient for numerical solution of Exner Equation, Downstream Boundary Cross Section.

DBN = Global; Weighting coefficient for numerical solution of Exner Equation, Downstream Boundary Cross Section +1.

DCDA = Global, The depth of clay sediment in the Active Layer.

DCDI = Global, The depth of clay sediment in the Inactive Layer.

DCDS = Global, The depth of clay sediment in the Subsurface Layer.

DD() = Modeling variable, Global, Computation time in days.

DDMX = Duration in Days, Maximum for the event; local variable; The duration of the event is stored in variable DD(N). The local name, DDMX is assigned in version 3 of EXNER.

DEAQMN(=) = Global; The water discharge corresponding to the minimum end area of deposition for all events. This is used in an error message. Set for QARRAY() < 0.

DEAQM(=) = Global; The water discharge corresponding to the maximum end area of deposition for all events. This is used in an error message. Set for QARRAY() > 0.

DECAY = Global, Array. Decay ratio for depositing sediment; local variable; The Amount of sediment which can settle out of the flow within a reach based on particle settling velocity and time required to flow thru the reach.

DED1 = Depth of scour to equilibrium if all bed material was of grain diameter D1, (figure B8-9).

DED2 = Depth of scour to equilibrium if all bed material was of grain diameter D2, (figure B-9).

DEPDR = Local, Depth of bed material available for Dredging.

DEPSSC() = Global, Depth of suspended sediment concentration in the water column. Used to track deposition of suspended sediment particularly in reservoirs where the sediment deposits slowly.

DEPXSIO() = Global. The initial Depth of the Cross Section as coded on GR Records.

DEQ = Local, Computational Variable. Depth of scour to equilibrium.

DF = Global Array.

DFT = Global, Scalar.

DH = Difference in elevation of cross section co-ordinate when modifying the previous cross-section for reuse at the current location.

DHU = Difference in velocity head between the downstream and upstream cross sections of a reach.

DHV = Global; Difference in Velocity Head between upstream and downstream ends of backwater reach.

DIF = A temporary storage variable used when taking the difference between two variables.

DIFFER =  $H(I) - V_{prime}$ , difference between current fall velocity and iterative computed velocity.

DIFMAX = Computational Variable, Local; The maximum difference between the Energy Line of Segment L1 and Segment L2 at NCPU in the trial and error calculations of the Closed Loop Solution.

DIL = Local, Scalar; Depth of InActive Layer, Used in Dredging Calculations.

DISTDV = Local; Length of reach for dredging volume calculation.

DLY = The depth in feet of sediment deposits over the elevations shown on the G-cards.

DLYR = Local; Depth of sediment deposits.

DLYOC() = Global; Modeling variable, Depth of Active Layer on OF Records, Ft.

DLYST() = Modeling variable, Global, Current depth of sediment in the Bed Sediment Reservoir, Ft.

DLYZO() = Modeling variable, Global, Initial depth of sediment in the Bed Sediment Reservoir, Ft.

DMAX = Maximum piece size of sediment particles (100 percent finer on gradation curve).

DNDA = Global, The depth of Noncohesive Sediment (sand and larger particles) in the Active Layer.

DNDI = Global, The depth of Noncohesive Sediment (sand and larger particles) in the Inactive Layer.

DNDS = Global, The depth of Noncohesive Sediment (sand and larger particles) in the Subsurface Layer.

DOD = Global, Scalar. Depth of over dredging.

DRCAP() = MODELING VARIABLE, Global, Dredging capacity of Dredge "J" in cubic yards per day.

DREA() = Global; Dredged channel end area.

DREVOL() = Global; Maximum volume of material that can be dredged at site "I" during the current event given the dredging capacity and event time.

DRH = Local; Hydraulic Depth of dredged cut -  $DREA/DRWIDE_1$

DRLC() = Global; Dredging distance coefficient. DRLC() is a value between 0 and 1 which shows how much of the reach has been dredged. It is a function of dredging capacity and computation time step.

DRNAME( ) = Global, Dredge Name. Used to Confirm dredging capacity input data

DRVSL = Local; Volume of material dredged from the SUB-Layer.

DRVT<sub>i</sub> = Global; Accumulated volume of sediment dredged from all cross sections at dredging site, i.

DRWIDE<sub>1</sub> = Local; Dredged Channel Width at Bed Surface

DRWIDE<sub>3</sub> = Local; Dredged Channel Width at top of Inactive Layer for Exner7. Dredged Channel Width at bottom of cut for Exner1 and 5.

DRWIDE<sub>4</sub> = Local; Dredged Channel Width at bottom of cut for Exner7.

DRWTAL = Local; Weight of material dredged from the Active Layer.  $DRWTAL = DRVAL * AUWAL$

DRWT<sub>i</sub> = Global; Accumulated weight of sediment dredged from all cross sections at dredging site, i.

DRWTIL = Local; Weight of material dredged from the Inactive Layer.  $DRWTIL = DRVIL * AUWIL$

DRWTSL = Local; Weight of material dredged from the SUB-Layer.  $DRWTSL = DRVSL * AUWSL$

DRWTXL = Local; Weight of material dredged from all layers at this cross section.  $DRWTXL = DRWTAL + DRWTSL + DRWTIL$

DS = Depth slope product.

DSDA = Global, The depth of Silt sediment in the Active Layer.

DSDEP() = Global Array. Maximum depth available in disposal site "J". (Not yet implimented.)

DSDI = Global, The depth of silt sediment in the Inactive Layer.

DSDS = Global, The depth of silt sediment in the Subsurface Layer.

DSRSID() = Global; Dredging from the residual layer at each cross section; total weight in tons.

DSWTWC() = Global; Dredged weight disposed into the water column at disposal site L for each grain size class I.

DTCL = Global, Scalar. Deposition threshold tractive force for clay material.

DTSL = Deposition threshold tractive force for silt material.

- DURH = Duration in days for Hydraulics; local variable; The shortest computation time interval to use in EXNER3. DURH is determined by either FTTDAY (flow thru time in days) or over-ridden by input data SPI (I1-1) card.
- DURS = Duration in days for Sediment Movement; local variable; The integration time-step in EXNER3 for the weight of sediment eroded, transported or deposited.
- DVOLZ1 = Global, Delta Volume of Bed Deposits in Zone 1 (Deposition or Erosion Zone.) during this Event.
- DVOLZ2 = Global, Delta Volume of Bed Deposits in Zone 2 (Deposition only Zone.) during this Event. This value is calculated as Sum of all BEDSWC(L)/UWSC(L) where UWSCI is the fully compacted specific weight.
- DWDH = Local; Rate of change in width of dredged cut with respect to depth. Used to Calculate the width of each bed layer, DRWIDE<sub>i</sub>
- DWS = Global Scalar. Difference between current and previous computed water surface elevations.
- DXPI = Diameter of grains that XPI is percent finer.
- DYI( ) = COMPUTATIONAL ARRAY, Incremental Bed Change during a Computation Time-Step
- DYO( ) = MODELING VARIABLE, Accumulated Bed change in feet at the beginning of a computation time-step.
- EAAL = Local; End area of dredging, active layer
- EADOCL = End Area of Deposit Outside of Conveyance Limits; Computed result; End area outside the conveyance limits that is required to store the sediment deposit of the current event. This is converted to bed-change and added to Y-coordinates using the EADOCL rule in the documentation.
- EAK = Local, Scalar. The end area which is required to store the volume of sediment deposited during this event in the erosion/deposition portion of the cross section. (Subroutine NEWGR) SEE AAK, AAS, and EAS
- EAS = The end area which is required to store the volume of sediment deposited during this event in the deposition-only portion of the cross section. (Subroutine NEWGR) SEE AAK, AAS, and EAK
- EASL = Local; End area of dredging, sub-layer.
- ECOM = Global, Scalar. Current value of the trial water surface elevation.
- ECOM1 = Global, Scalar. Trial water surface elevation from a previous trial.
- EDC = Global, Scalar. Elevation of dredged channel.
- efd = Global, Scalar. Effective Depth of Flow.
- EFDA( ) = Global, Effective Depth storage array.
- EFW = Global, Scalar. Effective flow width.

EFWA() = Global, Effective flow width storage array.

EGLOOP() = Computational Array, Global; The energy grade line at the upstream end of a closed loop. L = Segment number and i = 1 and 2 for the BASE discharge and the 1.1\*BASE discharge in the analysis.

EL = Global, Scalar. Elevation of total energy line at upstream cross section.

ELD = Global , Array.

ELM = Constant for converting percent to tons per day in the Larsen relationship for transport capacity.

ELMOD7 = Program Subroutine that calculates transport capacity by Larusen-Madden method.

ELSTO = Global, Array.

EMB = Global, Array. Elevation of model bottom.

EMIN = Global, Array. The elevation or discharge below which no water can enter a strip (or subsection of a cross section).

ELENCL = Local, Scalar. Elevation of Encroachment, Left Side of Cross Section. When this value is blank, the program automatically assigns DEPXSI() and blocks out the cross section at that elevation.

ELENCR = Local, Scalar. Elevation of Encroachment, Right Side of Cross Section. When this value is blank, the program automatically assigns DEPXSI() and blocks out the cross section at that elevation.

ENST = Global, Scalar. Station to End computations, Right Side of Cross Section. All stations greater than ENST are ignored. ENST does not insert points into the cross section; consequently, the depth of water is not added to the wetted perimeter at ENST. (SEE STST for Starting Station.)

ENTEXP = Global, Scalar.

ENTRLR = Entrainment Ratio; local variable; The ratio between the flow-depth and the reach-length required to achieve complete mixing when bed sediment is being entrained into the flow field. A constant of 20\*flow depth was assumed to be sufficient to achieve equilibrium concentration when entraining sediment from the bed.

ENTRTO = Global , Array.

ERRATE = Global, Array.

ETIME = Accumulated time for this integration sep; local variable; The accumulation of computation time in EXNER 3. When ETIME equals DDMX, integration is complete for that event.

EXILAL = Global, Array. Exchange of sediment from Inactive to Active Layer, tons.

EXPMX = Global, Program logic variable; largest exponent permitted by computer.

F = Global, Array.

F35 = Global , Scalar.

FABEL() = Storage Array, Global; The title line printed for each segment in the printout.

FAC = A temporary storage variable for accumulating volume beneath the surface profile.

FCDIAG = Global, Scalar.

FLAG = Global, Scalar. A program variable set equal to the smallest, previous value of \*dif\* during trial and error computations.

FLD() = Global, Input buffer.

FNDAT = Global, Programing feature variable. File name for the input data file.

FNGEO = Global, Programing feature variable. File name for the output file contining the calculated cross section geometry at the end of the run.

FNOUT = Global, Programing feature variable. File name for the output file contining the calculated results.

FNPLT = Global, Programing feature variable. File name for the output file contining the requested plots.

FQSH() = Global,

FREC = Global, Array.

FSFBL = Bed load function relationship shown as straight line, dashed , in Laursen relationship.

FSVFV = Shear velocity/fall velocity rataio.

FTTDAY = Flow Thru Time in DAYs; local variable; The time required for a water particle to flow thru the reach is calculated by reach length/flow velocity/86400sec. (See FTTS).

FTTS = Local; Flow Thru Time in Seconds; local variable; The time required for a water particle to flow thru the reach is calculated by reach length/flow velocity. (See FTTS).

FTTSEC = Flow Thru Time in SEConds, local variable; The time required for a water particle to flow thru the reach is reach length/velocity.

FTYPES = Global , Array.

FVCL = Global, Scalar. Particle settling velocity for clay.

FVSL = Global , Array.

FVSL() = Global, Array. Particle settling velocities for silts.

GAL = Global, Scalar. grain size in armor layer that is jusst stable at equilibrium depth.

GD = Global , Array. The primary sediment data array.

GD() = Global, General data array. GD contains the weight of sediment in the cover layer by size class; plus, it contains the primary hydraulic data for sediment transport calculations as follows:

GD( ) = General data array - total weight in active layer at this cross section of the bed sediment reservoir.

GD( ) = Global, Weight of sediment in the cover layer of the Bed Sediment Reservoir, by size class, for the WET portion of a cross section, within the conveyance limits.

GD(LGS+2) = Global, Reach length.

GD(LGS+3) = Global, Cross section identification number.

GD(LGS+8+1) = Global, DEPTH\*SLOPE product at each cross section for first Q. Used with MTC=2 (The user supplied transport function.)

GD(LGS+8+2) = DS for second Q (in parallel computations--obsolete) etc

GD(LGS+8+2NQ+1) = Top width at each cross section for first Q (Originally, up to 10 Q's were permitted in parallel computations. That is no longer true.)

GD(LGS+8+NQ+1) = N value in this reach for first Q (Originally, up to 10 Q's were permitted in parallel computations. That is no longer true.)

GD(NGS+1) = Total weight of all size classes in the active layer.

GD(NGS+2) = Reach length.

GD(NGS+3) = Average section number.

GD(NGS+8+1) = DS for first Q.

GD(NGS+8+2) = DS for second Q.

GD(NGS+8+2NQ+1) = Top width for first Q. etc.

GD(NGS+8+3NQ) = Top width for last Q in this reach.

GD(NGS+8+NQ)= DS for last Q.

GD(NGS+8+NQ+2) = N value in this reach for second Q in the parallel computation scheme.

GDLATS( ) = Global; The lateral storage array for the active layer. (i.e. When the movable bed dries, sediment is shifted from the active array, GD, into GDLATS. The process is reversed when the bed wets again.)

GDRSIDW( ) = Global; Residual weight in cover layer. (Originally in EXNER7 but REMOVED in Version 3.00 and assigned to the Inactive Layer, RESIDW())

GMOD = Subroutine to translate the geometric model input by user into one the computer can use.

GMI = Local; The inflowing sediment discharge to the reach times the duration of the computation time-step.

GMO = Local; The outflowing sediment discharge from the reach times the duration of the computation time-step.

GP = Global; Potential transport capacity. This is the sediment transport capacity before it is multiplied by percent of material in bed.

GPS = Global, Array. Clay is stored in the first 1/3 of GPS with clay passing x-section 1 stored in GPS(1); clay passing cross section2 in GPS(2)...etc. The original HEC-6 code could handle 150 cross sections; therefore, Silt passing x-section 1 was stored in GPS(151); Silt passing cross section 2 in GPS(152)...etc for the next 1/3 of GPS() followed by sand in bottom 1/3. Cross section 1 is the downstream end of the model and sequence numbers increase in the upstream direction.

GRAVB = Global; Base value in the gravel grain size arrays is 2.0 mm.

GRAVBF = Global; Base value in the gravel grain size arrays (i.e. 2mm) in feet.

GRCI = Global; Gravel size class interval.

GS() = Local, Calculated sediment discharge by particle size, tons/day.

GSCH() = Global; Transport potential from Schoklitsch or Meyer-Peter and Mueler when used in combination with Toffaleti

GSF = Global; Grain shape factor.

GSICP() = Global; Sediment discharge entering a control point.

GSISG() = Global; Sediment discharge entering a segment. This value applies to the inflow end of the segment and not just the upstream end.

GSIZFIT() = Global; Grain size in feet.

GSIZMM() = Global; Grain size in mm.

GSOCP() = Global, array, Sediment discharge leaving a control point.

GSOSG() = Global, array, Sediment discharge leaving a segment. This value applies to the outflow end of the segment and not just the downstream end.

GSR = Global, Array.

GSW = Global; Sediment Inflow Weight; The inflowing sediment discharge to the reach times the duration of the computation time-step.

GT = Total sand load in tons/day.

H = Global , Array.

HOTM = Computational Variable; Global; Allowable tolerance between calculated Heads for Split Flow in the Nashville District Patch. No longer used in Version 210.

HTOT = Computation Variable, Global; The total energy head at the upstream end of a closed loop.

HVT = Global, Scalar.

HYD = \$HYD, Program command. Hydrologic data follows.

I = General subscript counter fixed point variable, no specific definition.

IABS = A library subroutine for establishing the absolute value of an integer number.

IALP = A pointer that selects specific entry points on the control volume boundary relative to LALP.

IASA = Global, Scalar.

IASL = Global, Scalar.

IB = Temporary storage variable.

IBC = Logic Switch; Global; Internal Boundary Condition flag developed for the Nashville District Patch. No longer needed in Version 210.

IBLH = Pointer, array element no. of first value for upper portion of curve, Laursen's Sediment Transport Function as Modified by Madden.

IBLK = Global, Scalar.

IBLL = Pointer, Array element no. of first value of Laursen relationship in table, lower portion of curve.

IBS = A pointer variable locating the base element of the SSE(array) when utilizing the upper 8K of storage in a GE 225 or similar programming problem.

IBSHER = Global, Scalar.

IBSN = Global, Scalar.

IBX = A pointer variable locating the base element of the x(array) when utilizing the upper 8K of storage in a GE 225 or similar programming problem.

IBY = A temporary program variable specifying the ending index limit of a DO LOOP.

ICMD = Pointer; 39 was the command element number in the Numbers and Letters array. (FORTRAN66 coding)

ICPBR(L,2) = Global, Pointer. The control point number at each end of segment L. ICPBR(L,1) is downstream end; ICPBR(L,2) is upstream end.

ICPSG(ngds,i)= Global, IDENTIFIER.. Control Point number at each end of Segment. i=1 (D/S), i=2 (U/S)

ICRTON = Global, logic flag. Option for using normal depth approximation to water depth in supercritical flow reaches.

ICS = Global, Scalar. Identifies the smallest grain size of clay material to be transported.

ICSH(i) = Field Number on the R Record for the i<sup>th</sup> internal stage hydrograph. "i" ranges from 2 to MCSH. (See MCSH)

ICV = Counter DO LOOP index that counts increments from 1 to the total number of control volumes

(MSOR).

- ID = Global, Array.
- ID50 = Global, Array.
- IDBVT(L) = Global Identifier; Identifies the type of boundary condition at each Control Point. (none = 0; Stage(H) = 1; Water Discharge(Q) = 2; Sediment Concentration or Discharge(C) = 4)
- IDDV = Identifier; global; Identify Data Version (i.e. HEC6 for original Input Data Structure; UNET for reading the flow at each cross section; V210 for Version 2.10 Data Structure.
- IDF = Global, Scalar. Identifier, type of energy loss equation to use, Manning, weir equation, bridge equation.
- IDISP(I) = Array, Global, Dredging disposal site number for dredging site "I".
- IDM = Element in X and Y (ARRAY) representing left side of dredged channel (bottom), must have 3 co-ordinate points describing bottom of dredged channel.
- IDND = Logic Flag, Local; Identify No Dredging. IDND is set to 0 at the beginning of the dredging test on each cross section. If the initial "no dredging" test fails, at any co-ordinate in the dredged portion of the cross section, the IDND flag is set to 1. If the
- IDRY() = Logic Flag, Local; When the solution of the closed loop problem fails to converge it may be because one of the segments or the other is dry. One more iteration is always made in that case, and the IDRY flag tells the program that this is the second (last) test for a dry segment.
- IDS = Global; Identify specific requirement of subroutine HYDLMT.
- IDS D = Local, Identifier, Identify records which as either sediment load table LQ-LT-LF or sediment distribution coefficients = LQ-SD
- IDSTY() = Global; Type of disposal site; Specify with input data.  
0 = Disposal outside of model  
1 = Disposal at first x-sec downstream from dredging section.  
2 = Disposal at first x-sec downstream from this dredging site.
- IDTE = Local; Identify Deposition, Transport or Erosion
- IDTFGX = Global, Array.
- IE = Temporary storage variable.
- IECHO = Global, Scalar.
- IEN = A program variable which distinguishes ENST Values input from those assigned internally by the program.
- IENST = Global, Scalar. Pointer, points to LSS(array), addr for right side of last strip in the computations for that x-section.(See ISTST).
- IER1 = Global, Scalar.

IER2	=	Global, Scalar.
IERME	=	Global, Scalar.
IEXD( )	=	Global; Counter; Counts the number of times the cross section was overfilled with sediment above the water surface. Obsolete after version 4.37.
IFDC	=	Global; Counter; Counts the number of times the dredging algorithm was called.
IFINE	=	Program logic variable; local; If IFINE equals the number of sand=gravel classes, either all meet % tolerance for convergence in trial & error computations of the test for availability on bed to convey inflowing load thru reach.
IFM	=	Global; Element number in X and Y (ARRAY) to stop changing bottom elevation to simulate sediment deposits.
IFMT	=	Global, Logic Flag; Identify Format as HEC-2 or LRD-1
IFQS	=	Global , Array.
IFS	=	A pointer variable locating the base of each set of cross sections stored in the X and Y (ARRAYS), (Note * at bridges the low chord and top of road profiles are stored in the X and Y (ARRAYS) as well as the top off ground x-section.
IGDS	=	Loop Index; Global; The Initial (First) Geometric Data Set in the Network Calculations Loop (always = 1 in present code)
IGS	=	Global, Scalar. Initial ( first, smallest) sand size class to include in the calculations.
IHBT	=	Global , Scalar.
IHEC	=	Global; Pointer; Points to the index number (30) for the HEC flag in the array NUMLET.
II	=	The absolute location of each element in the LSS (ARRAY).
IK	=	Counter; working variable in Subroutine MRG.
ILCL	=	Pointer, points to relative positions of the clay size fraction in the IOTL ARRAY.
ILOOK	=	Program Logic Counter; local; Counts the number of cards (input data records) read by the program when it is trying to recover from an error in the input data.
ILSA	=	Pointer, points to the relative position of the sand size fraction in the IOTL ARRAY.
ILSL	=	Pointer, points to the relative position of the Silt size in the IOTL ARRAY.
IN	=	Global, Scalar. PRINT FILE LOGICAL UNIT NUMBER.
IN2	=	Locator, the relative location in the sediment rating table of the water discharge just above the value of Q.
INB	=	Global, Scalar.

INFO	=	Global, Scalar.
INM	=	Global, Scalar.
INS	=	Identifies the smallest grain size of non- cohesive material to be transported.
INT	=	Identifier, controls interpolation when calculating the inflowing sediment load from the rating table.
IOPD	=	Global; Identify option for shaping the cross section with Deposits.
IOPTX	=	Global, Logic Flag; Option for solving the Exner Equation.
IORBAS()	=	Locator; global; locates the BASE element in the operating rule arrays for the first operating rule on each segment. The subscript is NGDS.
IOTB()	=	Logic array, Counter; The column headings for size classifications to include in the B-Level printout table. (i.e. IOTB(1) = CLAY, IOTB(2) = SILT and IOTB(3) = SAND)
IP1	=	Dredging is emulated if IP1 equals 1, no dredging is performed if IP1 equals 2.
IPA	=	The interpolated point array is a program variable which keeps track of subsection stations which do not coincide with co-ordinate points so interpolated values can be inserted by the programmer for more efficient processing.
IPF	=	Global , Scalar.
IPLOT	=	Global, Logic Flag; Write the plot file.
IPX	=	The interpolated point counter accumulates the number of interpolated points inserted.
IPXS(I)	=	Identifier; Global; Cross Section Sequence number for Selective Printout
IQBT	=	Global, Scalar.
IQSH()	=	Global, Array.
IQUIT	=	Program Logic Limiter; local; Stops execution when ILOOK equals IQUIT.
IR	=	Counter on DO LOOP for number of reaches.
IRC	=	Counter; local; reverses the order of accessing cross section data for tracing sediment movement down the model.
IRCA	=	Index, Cross-section counter, reverse order as in decrementing from upstream to downstream direction, absolute location in the vector-array; global variable;.
IREC	=	Global, Array.
IRN	=	Global, Scalar.
IRUFF	=	Global, Scalar.

IS = Sometimes used when a variable is needed for the starting index of a DO LOOP.

ISA = Global, scalar.

ISBT = Global, Scalar.

ISCR = Global, Scalar.

ISE = A program variable which identifies a subsection station whose value is outside of the STST or ENST values specified in input data.

ISGCP(ncp,nx)= Identifier; Global; The segment numbers intersecting a Control Point. (i.e. Along with ICPSG this variable completes the transfer of knowledge between SEGMENTS and Control Points.)

ISGS = Identifies the smallest grain size of silt material that will be included in the calculations.

ISI = Global, Array.

ISM = Element in X and Y (ARRAYS) to start manipulating bottom elevations to simulate sediment deposits.

IST = A program variable which distinguishes STST values input from those assigned internally by the program.

ISTCD = Global, Scalar.

ISTME = Global, Scalar.

ISTST = Global, Pointer. Pointer points to LSS(ARRAY) addr for right side of first strip in the computations for that x-section. (See IENST)

ISXY = Identify for the program when G-cards are not present (no longer required but still permissible).

IT = Counter; working variable; used repeatedly as a temporary storage variable.

IT50K = Global, Scalar.

ITCL = Global, Scalar.

ITCPO = 0??

ITER = Variable to count number of iteration in velocity computations.

ITL = Global, Array.

ITM = The difference between the number of cross sections specified by NR on the P-card and the number of AVGS actually read by from A-cards.

ITMUD = Global, Scalar.

ITN = 0.

ITO = Global, Scalar.

ITP = Save the value of IPX for use later.

ITP95 = Global; TAPE 95 logical unit.

ITR = A program variable which identifies location in program for trace printout.

ITRB = Counter, DO LOOP index that increments from 1 to number of tributaries.

NTCV = (no. of tributaries) for each control volume.

ITSA = Global, Scalar.

ITSL = Global , Scalar.

IUNIT = Input logical unit numbers which change during calculations.

IV = Global, Array.

IWS = Logic Switch; Local; Instructs Hydraulics Whether H-Boundary Condition is prescribed by Stages or a Rating Curve.

IWSCP() = Pointer array, Global; The control point number for the downstream boundary rating curve or stage in a distributary. It is dimensioned to MXNCP.

IXS = A program variable which identifies which cross section in the X and Y (ARRAYS) is being analyzed.

IXSCP(ncp,nx)= Pointer; Global; Absolute Address in the ASN(array) for each cross section which joins each control point. {i.e. If the Control Point Number is known, Each cross section joining that control point can be located in ASN(nxsa)} SEE LXSCP()

IY = The Absolute location of each element in the Y (ARRAYS) is being analyzed.

J = Temporary storage variable.

JB = Temporary storage variable.

JBS = The element number in the X (ARRAY) whose value equals a subsection station, ENST or STST value.

JCTBAS = Global , Array.

JDF = Global, Scalar.

JF = Global, Scalar.

JJ = Temporary storage variable.

JL = Global, Scalar.

JP = Global, Scalar. Avariable which keeps track of current location in program for use in locating error messages.

JPN = Global , Scalar.

JPNO = Pointer; local; The junction point sequence number for the next tributary entering the segment computations arePresently being made.

JPNUM(JCTBAS(NGDS)) = Identification array, global; Associated junction point numbers with stream segment numbers.

JPSTO = Pointer; absolute; The location of tributary discharge and starting water surfaaace elevation in QTEP and WSR arrays.

JQL = Global , Array.

JQL() = Pointer array; global; The loccation in QTEP(). WSR(), andWTTEP() arrays where the water discharge, water surface elevation and water temperature values arae stored for the stream network.

JSL = Global , Scalar.

JTYPG() = Identifier; Global: Node Type - Based on Geometric Position in Network.

K = Temporary variable. Usually used in connection with output.

K1 = Local; Pointer; Points to the element number 1 in the Array NUMLET. (NOT USED AFTER 1993)

K3 = Local; Pointer; Points to the element number 3 in the Array NUMLET. (NOT USED AFTER 1993)

K4 = Local; Pointer; Points to the element number 4 in the Array NUMLET. (NOT USED AFTER 1993)

K5 = Pointer, absolute location of the total volume of bed material for each cross section CAR (ARRAY).

KA = Local; Pointer; Points to the element number for A in the Array NUMLET. (NOT USED AFTER 1993)

KAST = Global, Scalar.

KB = Local; Pointer; Points to the element number for B in the Array NUMLET.

KBL = Local; Pointer; Points to the element number 37 which points to 'blank' in the Array NUMLET.

KBR = Program Variable used to hold a statement number.

KC = Local; Pointer; Points to the element number for C in the Array NUMLET. (NOT USED AFTER 1993)

KCMD = Global, Scalar.

KCMT = Global , Scalar.

KD = Local; Pointer; Points to the element number 14 which is 'D' in the Array NUMLET.

KDEC = Not used, remove from program.

KDU = A dummy name assigned for sole purpose of providing a statement number.

KE = Local; Pointer; Points to the element number 15 which is 'E' in the Array NUMLET.

KF = Locator, absolute location of base element for the entire dataset for each cross section, CAR (ARRAY).

KFCR = Global, Scalar. A counter variable to distinguish between the first and subsequent entries into subroutine ERROR for current cross section.

KFT = Global, Logic Flag. An identifier variable to distinguish between the first and subsequent cross sections in Backwater Calculations.

KG = 17 Global, Scalar. Pointer, address of the letter G in the NUMLET array.

KH = 18 Global, Scalar. Pointer, address of the letter H in the NUMLET array.

KJ = 20 Global, Scalar. Pointer, address of the letter J in the NUMLET array.

KK = 21 Global, Scalar. Pointer, address of the letter K in the NUMLET array.

KL = 22 Global, Scalar. Pointer, address of the letter L in the NUMLET array.

KLEFT = Global, Scalar. Pointer, # of the first x- coordinate in the computations for area, wetted perimeter and conveyance. (see KRITE).

KM = 23 Global, Scalar. Pointer, address of the letter M in the NUMLET array.

KN = 24 Global, Scalar. Pointer, address of the letter N in the NUMLET array.

KO = 25 Global, Scalar. Pointer, address of the letter O in the NUMLET array.

KP = 26 Global, Scalar. Pointer, address of the letter P in the NUMLET array.

KQ = 27 Global, Scalar. Pointer, address of the letter Q in the NUMLET array.

KQCH = Global; Program Flag; A program variable which identifies the presence of a Local Inflow in the reach data set.

KR = 28 Global, Scalar. Pointer, address of the letter R in the NUMLET array.

KRITE = Global, Scalar. Pointer, # of the last x- coordinate in the computations for area, wetted perimeter and conveyance. (See KLEFT).

KS = 29 Global, Scalar. Pointer, address of the letter S in the NUMLET array.

KSAVE = Global , Array.

KSE = The element number in the LLT (ARRAY) equal to 1 for testing STST and 2 for testing ENST values for interpolation in the X and Y (ARRAYS).

KSKEW = Global, Scalar. A counter variable which keeps track of number of lines printed for use in determining when to skip to a new page.

KSL() = Program Logic FLAG; Global; Simulated Sense Light, Set to ON to identify some condition and turned off when that condition is tested.

KSW = Global , Array. A variable to simulate sense switches in program logic. Turns printout on.

KSWDR = Global, Array.

KSWI = Global, Array.

KT = 30 Global, Scalar. Pointer, address of the letter T in the NUMLET array.

KU = 31 Global, Scalar. Pointer, address of the letter U in the NUMLET array.

KV = 32 Global, Scalar. Pointer, address of the letter V in the NUMLET array.

KW = 33 Global, Scalar. Pointer, address of the letter W in the NUMLET array.

KX = 34 Global, Scalar. Pointer, address of the letter X in the NUMLET array.

KXY = A variable to identify cross sections coded (elevation, station) on G-cards.

KY = 35 Global, Scalar. Pointer, address of the letter Y in the NUMLET array.

KZ = 36 Global, Scalar. Pointer, address of the letter Z in the NUMLET array.

L = A temporary storage variable.

L1 = Local, Pointer; Segment number for closed Loop Solution (SEE L2)

L2 = Local, Pointer; The other Segment number for closed Loop Solution (SEE L1)

L5 = The absolute location of the array element containing total sand for each cross section, GD (ARRAY) (not the absolute location in computer memory but in the GD (ARRAY) (not the absolute location in computer memory but in the GD (ARRAY)).

LALP = Locator, the base element in ARRAY GD which locates values of accumulated volumes of sand, silt and clay that are moving past each entry point, and end boundaries.

LALT = Locator; global; The base location in the GD(array) for accumulating volumes of inflow and outflow by clay, silt, sand classes for trap efficiency computations.

LASA = Global, Scalar.

LASL = Global, Scalar.

LB = A pointer variable locating the base element of each cross section stored in the X and Y (ARRAY) at an average section.

LBCL	=	Global, Scalar. Base locator; The base locator for clay in the GPS (ARRAY). With clay in the top 1/3 of the GPS array.LBCL equals 0.
LBCPH	=	Base Locator; local; The absolute element # in QTEP, WSR and WTTEP where downstream boundary values are stored for each segment of the stream network. (sounds too similar to JQL for both descriptions to be correct, Needs clarification.)
LBEDL	=	Global; Limit of number of bed layers in the model. LBEDL = 2 for Exner 1 and 5. LBEDL = 3 for Exner 7.
LBLAY	=	Global, Limit of the number of clay layer types prescribed on the I2-Records. Usually this value is 1.
LBSA	=	Global, Scalar. Base locator; The base locator for sand and larger in GPS(array).
LBSL	=	Global, Scalar. Base Locator; The base locator for silt in the GPS(array).
LC	=	Global, Scalar. The number of coefficients at each cross section, relating volume to depth of sediment deposits.
LCH	=	Global, Scalar. The subsection number for the channel subsection. The corresponding strip number is NMU(LCH).
LCS	=	Identifies the largest grain size of clay material to be transported.
LD	=	Point, Local; Segment number of the Dry Segment, Island Flow Calculation.
LDA	=	Global; Pointer, relative; add to L5 to get location of DXPI in GD(array).
LDM	=	Global; Pointer, relative; add to L5 to get location of DMAX in GD(array).
LEB	=	Global; Pointer, relative; add to L5 to get location of Equilibrium Bed Elevation in GD(array).
LENDAT	=	Global, Length of filename, input data file.
LENCEO	=	Global, Length of filename, end of run geometry file.
LENLSD	=	Global, Length of filename on left side of decmile, input file.
LENPLT	=	Global, Length of filename, plot file.
LEVEL0	=	Program logic variable, local; If LEVEL0 equals # of grain sizes (sand+gravel at present-14 Nov 85) then "all grain sizes deposit." Section 7, Exner 3.
LEVEL1	=	Program logic variable, local; If LEVEL1 equals # of grain sizes (sand+gravel at present-14 Nov 85) then "all grain sizes erode." Section 8, Exner 3.
LEVEL2	=	Program logic variable; local; If LEVEL2 equals # of grain sizes (sand+gravel at present-14 Nov 85) then some sizes deposit and some erode...ie referred to as sorting between flow-field and bed.
LF	=	The base element for the data set of each cross section, GD(ARRAY), load for the smallest grain size class is in array element (LF+1)ETC.

LFA	=	Global, Scalar. A variable which identifies whether Coriolis coefficient is to be calculated or set equal to 1.
LGA	=	Global , Scalar.
LGD	=	Identify the element number in the SD (ARRAY) where the last (most course) grain size diameter to be considered is stored.
LGS	=	Global, Scalar. Last (final, largest grain size class to include in the analysis.
LHN	=	Number of values in table, Laursen relationship, upper portion of curve.
LIMDO	=	Global, scalar. Counter/limit number of strips in this reach (either NSS or NSSO whichever is larger).
LINE	=	Global, Scalar. Program Logic Control; The number of lines on a printer page.
LIPG	=	Locator; local; The location in the cross section data arrays where local inflow computations are to be made.
LIXS()	=	LOCATOR, Global, Base location in Cross section array (Downstream Cross Section) for the Local Inflow Point
LJGM()	=	Locator array, Global; The cross section sequence numbers where junctions occur on each

LOOPI = Global, Counter; The number of iterations when converging an Closed Loop Solution.

LP = Global, Unit number for printout file.

LPA = Global , Scalar.

LPST = Flag; local; Turns on and off program logic that accumulates sediment from a control volume into the GD array.

LQ = The number of water discharges in the sediment inflow rating table for the main stem.

LQSL(j,k) = LOCATOR, Global, Base location in CAR(array) for the Local Inflow Q-Qs rating table.

LQT = Global, The number of water discharges in the sediment inflow rating table for each Tributary.

LSA = Global; Pointer, relative; add to L5 to get location of SAE (surface area exposed) in GD(array).

LSGOUT = Global, Counter; The number of segments which join a control point and have outflows.

LSGS = Identifies the largest grain size of silt material that will be transported.

LSOR(MSOR) = Counter; Global; The number of Operating Rules on each Branch of the Network. The D/S boundary is always one. Internal Control Points prescribed with X5 Records is flagged as an Operating Rule Location. This Logic was completely redesigned in version v210. LSOR is no longer needed.

LSS = Global, Array. Locator (ARRAY), locates element number in X and Y ARRAYS where a strip line intersects a cross section

LTEL = Global; Number of Local Inflow Points. Obsolete for version 4.00 and later.

LTGM = Global, Array. Locator; Tributary entry point in geometric model. The cross section number on the stream segment where local inflow enters the model. This locator is relative to the segment and must be added to NTRBAS to obtain the absolute location # in ASN where the first cross section for each stream segment is stored.

LTI = Control, the total number of integration intervals to use in calculating sediment movement.

LTIA = Global; Number of Tributary Inflow Points. Obsolete for version 4.00 and later.

LTIV = Local, Limit, number of flow thru times based on Velocity; The number of times a particle of water would flow thru the reach during the duration of this event.

LTSA = Global; locator; Base location of sand discharges in array GPS.

LTSI = Global; locator; Base location of silt discharges in array GPS.

LTSR() = (Not used in version 4 -- but still hanging around)

LUG = Global, Scalar. (see handwritten sidebar notes on pg B13.)

LW = Point, Local; Segment number of the Wet Segment, Island Flow Calculation.

LXSCP(ncp) = COUNTER, Global, Total number of Cross Sections Joining a Control Point

MAGO = Global, May Go is a Warning-Error counter.

MATGM = Global, MATGM=5

MAXNF = PARAMETER; Maximum number of fields in findlm logic

MCSH = Total number of internal stage hydrographs coded on the R Records. (i.e. hinged pool operating curves.)

MEID = Counter, the number of D-cards to be read.

METHOD = Global , Array.

METRIC = Program Logic Switch; Global; English/Metric Switch.  
0 = ENGLISH IN; ENGLISH OUT  
1 = METRIC IN; METRIC OUT  
2 = ENGLISH IN; METRIC OUT  
3 = METRIC IN; ENGLISH OUT

MFTOC = Global , Array.

MIXQSG = Global, PARAMETER; The number of positive or negative flows on a segment. If MIXQSG equals the number or cross sections on that segment, there are no mixed flows.

MNQ = Limit, the number of parallel Water Discharges.(Obsolete)

MNTL = Maximum number of Local Inflow/Outflow points in the current network

MOMEN = Global, logic flag. 0 means set momentum loss to zero; 1 means calculate momentum loss at junctions.

MOPR = Global , Scalar.

MSD = Global, Scalar.

MSOR = Global, Maximum number of operating rules in the network.

MTC = Global, Scalar. Identifier, transport capacity function to use this job.

MTCL = Global, Scalar. Identifies the method to be used for transporting the clay load.

MXCAR = PARAMETER, Maximum size of CAR(ARRAY)

MXDRL = PARAMETER, Maximum number of dredging sites.

MXERR = Maximum number of times the deposition can exceed the water depth before computations are stopped.

MXF = Last co-ordinate wetbed.

MXFLD = PARAMETER; MX # OF FIELDS ON A RECORD

MXGD = PARAMETER; MX SIZE OF GD(ARRA0  
 MXKSW = PARAMETER, Maximum Number of elements in KSW(array)  
 MXL( ) = Global , Pointer, Array index for first movable GR-station within the Wet Bed.  
 MXLIP = PARAMETER; Global; Maximum No of Local Inflow Points on a Segment in the Network  
 MXLQ = PARAMETER; MX # OF WATER DISCHARGES IN Q-QS TABLE, MAIN  
 MXLQT = PARAMETER; MX # OF WATER DISCHARGES IN Q-QS TABLE, TRIBS  
 MXNCL = PARAMETER; MX # OF CLASSES if sediment sizes  
 MXNCO = PARAMETER; MX # OF NON-COHESIVE CLASSES  
 MXNCP = PARAMETER; Global; Maximum No of Control Points in a Network  
 MXNGS = PARAMETER; Global; Maximum No of Grain Sizes  
 MXNSCG = PARAMETER; MX NUMBER OF SIZE CLASS GROUPS (CLAY-SILT-SAND/GRAVEL)  
 MXNSE = PARAMETER; MX # OF SCALER VALUES PER X-SEC IN GD(ARRAY)  
 MXNST = PARAMETER; MX # OF STRIPS PER X-SEC  
 MXNVS = PARAMETER; MX # OF SCALAR VALUES IN TOP OF CAR(ARRAY)  
 MXNXS = PARAMETER; Global; Maximum No of Cross Sections in the Network  
 MXNXY = PARAMETER; MX # OF (STA,ELEV) COORDINATES PER X-SEC  
 MXOPR = PARAMETER; Global; Maximum No of Operating Rules in the Network  
 MXOQC = PARAMETER; MAXIMUM NUMBER OF Q'S IN LOOP DISTRIBUTION COEFFICIENT TABLES  
 MXPLOT = PARAMETER; MAXIMUM NUMBER PLOT VARIABLES  
 MXQ = PARAMETER; MX # OF WATER DISCHARGES IN PARALLEL  
 MXR( ) = Global , Pointer, Array index for last movable GR-station within the Wet Bed.  
 MXS = First co-ordinate in wetbed.  
 MXSG = PARAMETER; Global; Maximum No of Segments in array dimensions.  
 MXSGCP = PARAMETER; Global; Maximun No of Segments Joining a Control Point  
 MXSOR = PARAMETER; MX # OF STORAGE OPERATING RULES  
 MXSWEP = PARAMETER; MAXIMUM NUMBER OF SWEEPS ..FOR FLOW REVERSALS

MXTLP = PARAMETER; MX # OF TRIBS + LOCALS  
 N = The element number in the Q(ARRAY) of the discharge currently being used.  
 NAP = Base Locator in CAR array, n-value correction for user supplied Sediment Transport Function  
 NAQ = Base Locator in CAR array, Main stem Boundary Condition, Sediment Inflowing Rating Table, External Boundary Condition Point  
 NBRCP(ncp)= COUNTER.. Number of segmentes at each control point  
 NCAR = Counter, Number of values in CAR array  
 NCBCL = Global, Scalar.  
 NCH = Counter, the number of E-cards to be read.  
 NCP = COUNTER, Global, Control Point Number, General  
 NCPD = POINTER, Global, Control Point Number at D/S end of Segment  
 NCPE = COUNTER, Global, Number of Control Points Having External Boundary conditions  
 NCPU = POINTER, Global, Control Point Number at U/S end of Segment  
 NCSH =  
 NCV = Number of control volumes for which trap efficiency is to be calculated, a typical example - when several reservoirs are in the system each can be considered a "control volume", so its trap efficiency will be calculated. NO USED IN VERSION 4.00 (1994).  
 NDBE = Global , Array.  
 NDEFAT = Global, scalar; The number of times when Deposition exceeded the allowable end area of flow; used in error message at end of job.  
 NDREX = Global, Array.  
 NDREXS(J) = COUNTER, Global, Number of Cross Sections in Dredging Location J. (SEE NDRLOC, NDSLOC, NDSXD, NDSXN)  
 NDRLOC = COUNTER, Global, Number of Dredging Sites. Each time the dredging rate or disposal location changes, a new Dredging Site must be prescribed. (SEE H-Series of Record, Geometric Data Set.)  
 NDRR(I) = COUNTER, Global, Logical flag for Dredging Reach. NDRR(I) = 0 if cross section I is not included in dredging requirements; NDRR(I) = NDRLOC (the Dredging site #) when dredging is requested at cross section I; NDRR(I)=-NDRR(I) when dredging is completed at cross section I. (SEE NDRLOC, NDSLOC, NDSXD, NDSXN)  
 NDS = The element number of the slope or depth\*slope for discharge no 1 at the first (most downstream) cross section is NDS+1.

NDSLOC = COUNTER, Global, Number of Disposal Areas. (SEE NDRLOC, NDSLOC, NDSXD, NDSXN)

NDSPXS(J) = Array, Global, Number of X-sections in disposal site "J".

NDSR = Global, Array.

NDSXD( ) = Global, POINTER, Cross Section sequence number of the first disposal area when dredging. (SEE NDRLOC, NDSLOC, NDSXD, NDSXN)

NDSXN( ) = COUNTER, Global, Number of Cross Sections in Disposal area J

NEB  
NEC=0 = Locataor, absolute location of base element for the equilibrium bed elevation in GD (ARRAY).

NED = Global, Scalar. the element number for the effective depth for discharge no. 1 at the first (most downstream) cross section is NED+1.

NEOT = Global , Scalar.

NEQ = Global, Scalar. The maximum number of N-values plus elevation or discharge values on each E-card, presently set equal to 10 values or 5 co-ordinate points.

NETCAR( ) = LOCATOR, Global, Base position in the CAR array for all CAR data for Segment K.

NETGD( ) = Locator;global; The base location in GD(array) for each segment of a stream network.

NETLQ( ) = COUNTER, Global, Number of Q's in the Q-Qs Rating table for control point NCP.

NETNAP( ) = LOCATOR, Global, Base position in the CAR array for the coefficients for Method 2, supply your own transport function. Only 1 set are permitted for the model.

NETNAQ( ) = LOCATOR, Global, Base Location in CAR(array) of the Q-Qs Rating Table for each Sediment inflow Boundary Condition Control Point.

NETNGR( ) = LOCATOR, Global, Base position in the CAR array for the initial depth in the Bed Sediment Reservoir.

NETNIS( ) = LOCATOR, Global, Base position in the CAR array for size fractions for the Inactive Layer composition.

NETNTC( ) = LOCATOR, Global, Base position in the CAR array for the DS coefficient (1 for each cross section) when using Sediment Transport Method 2, the Supply your own Function method.

NETNXS( ) = (LOCATOR,COUNTER) Global, The (K,K1) value is the Base Location of the first cross section on SEGMENT K in all arrays having length = number of cross sections. The (K,K2) index is the number of cross sections on SEGMENT K.

NETNYV( ) = LOCATOR, Global, Base position in the CAR array for Bed Widths. **This variable was used when volumes were calculated from average end areas. It has been obsolete since 1980, but the positions in the CAR array required retaining this locator.**

NEVNT = COUNTER, Global, Current Number of Water Discharge Events read by model.

NEXDA = Global, Counter; The number of cross sections having deposits which exceed the cross sectional area.

NEXDE=0

NFBYC = Global ,Scalar.

NFUN = Global, Flag. A dredging operation is in progress if NFUN > 0.

NGD = Global , Scalar.

NGDS = POINTER, Global, Number of current Geometric Data Segment.

NGEOT = I/O unit number, global; The logical-unit number for the geometric data tape.

NGR = Base Locator in CAR array, BED Ys at Time = 0

NGRCL = Global, Scalar.

NGS = Global , Scalar. The number of grain sizes being analyzed.

NGS1 = POINTER, Global, Number of grain sizes + 1

NGSIZ = Number of grain sizes; local variable; The number of grain size classes to use in the LEVEL0, LEVEL1, LEVEL2 or IFINE tests, EXNER3 solution of Exner Equation.

NIS = Global, SCALAR. Number at immobile supply - locates the base element in the CAR ARRAY for distribution of grain size fractions by volume (tons) present in the portion of the bed that does not move.

NJUNCT = Pointer, local; Element # in the geometry array where the reach number is stored for tributary junctions on this segment. A Workinf variable which is incremented (or decremented) by 1 after each use and set equal to the base locator JCTBAS(NGDS) for the initial value on each segment.

NK = Global, Scalar. The number of elements in the GD \*(ARRAY) that are required for storing a complete set of data for one cross section.

NLIP = Counter; global; The number of local inflow points on this segment of the stream network.

NLOCAL() = Global, LIMIT, Number of local inflow/outflow points on stream segment K

NMD = Global, Array. A special program variable that matches subsections of the downstream cross section with the correct strip through the reach.

NMDR = The input variable name for NMD.

NMU() = Global,Pointer array which aligns subsections of the upstream cross section with those of the downstream for average end area computations in the hydraulic calculation of water surface profiles.

NNV = The element number of the N-value for discharge No. 1 at the first (most downstream) cross section is NNV+1.

NOBED = Number of BED layers; local variable; The number of layers of sediment available in this reach. It includes both active and inactive bed layers. "Availability" means PRESENCE as constrained by the number of times sediment can exchange with the flow determined by  $LTIU \text{ equals event duration in seconds} / (\text{Shear Velocity in seconds})$ .

NODETY( ) = LOGICAL FLAG, Global, Node type (Each cross section is assigned a node type which controls the sequence of sediment movement calculations).

NOGO = Global, COUNTER, The number of fatal errors detected by the program.

NORDER = Index, local; Sediment computations start at the most distant branch in the network and work backward-toward the downstream end of the model. NORDER is the stream segment number in that case and denotes a decrement whereas NGDS which is also stream segment number, is incremented.

NORSG( ) = COUNTER, Global, Number of Operating Rules on each Segment. (OBSOLETE, Segments are no longer partitioned into Control Volumes by X5 Records. Each X5-Record initiates a new segment number.)

NOTICE = Global, Array.

NPAR = Global, Scalar. The strip number for which data on an E-card applies.

NPTSR = (Not used in version 4 -- but still hanging around)

NQ = Global, Scalar. The total number of discharges read into the Q (ARRAY).

NQQS = Global, Scalar.

NQSLV(i,j) = Global, Limit; The number of co-ordinate points in a sediment inflow/outflow rating table for local inflow point i on segment j.

NR = Counter, Global, Number of Cross sections on a Segment of the network.

NR1 = The number of cross section minus 1.

NRBASE = Locator, Local, The base locator for cross section data for each segment in the network. All arrays having the dimension MXNXS. SEE NETNXS(K,1)

NRE = Number of values in array REsult; counter in MRG.

NSACL = Global, Scalar.

NSE = The Number of elements in the GD (ARRAY) reserved for single pieces of data at each cross section .

NSFR = Global, Scalar. Number of sediment fraction groups (IE clay silt or sand).

NSG = Global, counter/index; The number of the current segment.

NSL = The element number in the LSS (ARRAY).Which points to the final cross section coordinate to be considered in calculating hydraulic elements.

NSLU = SLUE DOWN 2

NSPI = Global , Scalar.

NSS = Global, Scalar. Counter/limit, number of subsection stations at upstream cross section.

NSSO = Number of subsections in the cross section, D/S end of reach

NSTOT = Global, Scalar.

NTC = Base Locator in CAR array, Qs vs DS coefficients, (A, B and C) for MTC=2 (user supplied Sediment Transport Function)

NTCV = Global, Array. Number of tributary entry points in eaach control volume.

NTEL() = Global, Array. Counter; The number of local entry points on each segment of the stream network. The subscript refers to stream segment number. (v209)

NTIGEO = COUNTER, Global, Number of title cards in the geometric data for each segment of the network.

NTISED = COUNTER, Global, Number of title cards in the sediment data for each segment of the network.

NTJP = Counter; global; The number of tributary junctions on this segment of the stream.

NTJUN() = Counter array; global; The number of tributary junctions on each segment of the stream network. The subscript refers to stream segment #.

NTPL = Global, Counter; The number of tributaries plus locals on a segment of the stream network.

NTRB = Counter; local; The # of tributaaries between this cross section and the downstream end of this segment. Relative to each segment.

NTRBAS(K)=

NTW = Locator, absolute location of base element for effective widths in GD(ARRAY).

NU = Dynamic viscosity.

NVA = The element number for the average velocity for discharge No. 1 at the first ( most downstream) cross section is NVA+1.

NVE = The # of elements reserved in the CAR (ARRAY) for storing miscellaneous data for linkage between various subroutines.

NVS = Global, Scalar. The base element in the CAR (ARRAY) where the volume VS shape factor is stored.

NWS = Global, Scalar. Locator, absolute location of base element for water surface elevations in GD (ARRAY).

NWSP = COUNTER, Global, Current number of the water surface profile calculation.

NWTC = LOGIC, Global, Number of words on each Title Record

NXDRED( ) = Global, Array. Sequence Number of X-Section at the downstream end of the dredging reach. Dredging site "I".

NXS = INDEX, Local, Sequence Number of the current cross section relative to the first cross section on the Segment.

NXSA = Pointer, Global, Absolute Sequence Number in the cross section arrays, ARRAYS dimensioned to MXNXS, for the current cross section data.

NXY = Global, Scalar. The number of cross section coordinates entered for current cross sections.

NYU = Number at (Y,V) - locates the base element for depth of deposits VS volume of deposits coefficients in the CAR(ARRAY).

NYV = Global, Scalar. The pointer variable locating the base element of the depth VS volume of deposit data stored in the CAR (ARRAY).

P = Global , ARRAY.

P84 = Global. 0.84 to be used in calculation for 84 % finer.

PBT = Global , Array.

PCAL = Local. Percent of the Active Layer made up of clay.

PCIL = Local. Percent of the Inactive Layer made up of clay.

PCSL = Local. Percent of the sublayer made up of clay.

PED = Percent finer value for which effective diameter is needed.

PF = Global , Array.

PFAXIS = Global, Array.

PFINER = Global , Array.

PII = Global , Array.

PIN = Percentage (fraction ) of that size class in the active layer; local variable.

PIO = Percentage (fraction), Old; local; he fraction of each size class in the active layer from the previous computation time-step.

PS = Global , Array.

PSAL = Local. Percent of the Active Layer made up of silt.

PSAS = Local. Percent of the Active Layer made up of non-cohesive sediments (sands and larger).

PSIL = Local. Percent of the Inactive Layer made up of silt.

PSNI = Local. Percent of the Inactive Layer made up of non-cohesive sediments (sands and larger).

PSNS = Local. Percent of the sublayer made up of non-cohesive sediments (sands and larger).

PSSL = Local. Percent of the sublayer made up of silt.

PUCD = Global, Scalar. Specific weight for fully compacted clay deposits, tons/cubic foot

PUCDLB = Global, Scalar. Specific weight for fully compacted clay deposits, pounds/cubic foot

PUSD = Global, Scalar. Specific weight for fully compacted silt deposits, tons/cubic foot

PUSDLB = Global, Scalar. Specific weight for fully compacted silt deposits, pounds/cubic foot

UWDLB = Global, Scalar. Specific weight for sand and larger deposits, pounds/cubic foot. Sand does not compact

Q() = Global, Water discharge, CFS.

QARRAY(I) = Storage Variable, global; The water discharge at each cross section for an event. I goes from 1 to the number of cross sections.

QCH = Global, Scalar. Water Discharge in the channel subsection.

QDIR = Global, Scalar.

QINCP(L) = Global, Computation array, water inflow to each control point.

QLOCAL(i,j) = Global, Computational array, Water Discharge at Local Inflow/Outflow point i on Segment j of the Network.

QLOOP(L,i) = Global, Computational Array; Water Discharge at the Upstream End of each segment in a closed loop solution. The value of i is either 1 for the BASE Q or 2 for the 1.1\*BASE Q.

QMAIN = Computation variable; local; The water discharge in the main-stem after a tributary of local inflow discharge has been subtracted.

QOC(L,i) = Computation array, global; The coefficient for water discharge entering Segment L. This variable is 1 for all junctions having only 1 outlet segment. It is the fraction of water entering each segment of a closed loop or distributary. It is set up to vary the coefficient as the water discharge increases, but at present only one value can be entered.

QOTCP(L) = Computation array, water outflow from each control point.

QS = Inflowing sediment load for a particular water discharge in the sediment load rating table.

QSDC(L) = Global; Calculation variable. Sediment distribution coefficients at an Internal Junction in a distributary or Island Flow Calculation. Particle Size Index is L.

QSDCA(NGDS,NSG,I,L) = Global; Input Coefficient Storage Variable. Sediment Distribution Coefficients at an Internal Junction. NSG is [1= D/S or 2 = U/S] end of segment. I is Table

Parameter Index (Range is from 1 to 9 QW Values). Particle size class index is L.

- QSTEP = Global , Array.
- QTD = Water discharge \* constant that converts units of Laursen relationship to tons/days.
- QTEP = Global, Array. Water discharge at each tributary entry point.
- QTOT = Computation variable, global; The Total water discharge at the upstream junction of a closed loop.
- QVJUN(L) = Computation array, water volume at each junction.
- QVLOC(J,K) = Computation array, water volume at each local inflow/outflow point.
- QX = Computation variable; local; The water discharge used in Q-QS table interpolations.
- R = Global, Array. Hydraulic radius of each subject in at the current cross section.
- RAT() = Global, The stage - discharge table for the downstream boundary condition.
- RE = Global, Array. Current value of reynolds number.
- RESULT = Working variable in sub. MRG; The array where STA, VALLS & VALRS are merged.
- REY = Global, Array.
- RHO = Density of fluid; global variable; Density of water.
- RL = Global, Array. Reach length between the current and previous cross sections.
- RO = Global, Array. Hydraulic radius of each subsection at the previous cross section.
- RRP = Ratio of grain size to D50 for each size classification in the Laursen transport function.
- RSABS() = Computation array, The reciprocal of the Surface Area of the Bed, Storage Portion of each cross section.
- RSIDW() = Global. Residual Weight. This is the weight of sediment which is present in the Bed Sediment Reservoir but is not included in the Sediment Model. Often the fractions selected for the sediment model do not sum to 100%. The residual is the difference between their sum and 100%.
- RSLATS() = Global, Reciprocal of the Lateral Storage Weight, Sub-Layer
- RTOK = Local. The ratio of the Width of the Current Wet-Bed divided by the Width of the Previous Wet Bed. RTOK is used to calculate the weight of sediment deposits in the current wet bed.
- RX = A ratio to multiply times the cross section values of the previous section to obtain a current cross section.
- SA = Global, Array. Area of each subsection at the current cross section.
- SABK() = Global; Bed surface area of the Wet Bed portion of the cross section which is within the erosion limits, sq ft, new time step.

SABKI() = Global; Initial value of SABK().

SABKO() = Global; SABK() for previous time step reach.

SABS = Global, Array, Bed surface area of storage portion of cross section for each reach, sq ft.

SAC = Local, Scalar, Surface Area Covered by the Active Layer.

SACI = Local, Scalar. Surface Area Covered by the Inactive Layer.

SAD = Global, Array.

SAE = Global, Scalar, Surface Area Exposed to scour.

SAG = Local, Scalar. The standard Acceleration of gravity at sea level, latitude 45 degrees is 32.174.

SANDMM() = Global. Sand Size Classes in mm.

SD() = Global. The geometric mean diameter of each sediment size class.

SDAD() = Global. The Sum of  $D*AD^{2/3}$ . This parameter is used in the calculation of Effective Depth.

SDL() = Global. The logarithm of the sediment size classes expressed in feet.

SE = Global, Scalar. (1) Sill (or crest) elevation for a weir; (2) Datum change for elevations at a cross section.

SEBD = Local Variable, Scaler, Cross Sectional end area above the surface elevation of the bed. (Used in the dredging algorithm to establish the cross sectional end area before dredging.

SF = Global, Array.

SGC = Slope of gradation curve between any two discrete points

SGSL = Global, Specific gravity of individual silt particles.

SGSP() = Global, Array. Specific gravity of individual sediment particles. Same as scalar values but put into array for ease of computations in loops.

SGSSP() = Global, Array. Submerged specific gravity of individual sediment particles. Same as scalar values but put into array for ease of computations in loops.

SHIFT = Datum shift for a stage-discharge rating curve.

SHV = Shear velocity.

SIBC() = Storage array; local; The inflowing sediment discharge for the current event is computed from the Q-QS tables and stored in SIBC for each grain size and each segment of the network.

SL = Global, Scalar. (1) Sill (or crest) length for a weir; (2) cross section length, or skew, multiplier.

SLDTSL = Global, Array.

~~SLATS() = Global; Total of all size classes, Sublayer, Lateral (non-WET Bed) Storage weights, Bed Sediment Reservoir.~~

SLOA() = Global, Storage array for slope for sediment transport calculations.

SLRSIDW() = Global; Sublayer, Weight of Residual in Sublayer, WET bed portion of the Bed Sediment Reservoir. (i.e. the Residual is the remainder of the bed gradation when the percentages of the size classes, which were selected for inclusion in the transport calculations, do not sum to 100%. It was in Copeland's original Exner7, but it was made inactive for Version 3.00 of the Code and all residual was placed into the Inactive Layer as it was in the original HEC-6.)

SLRSLAT() = Global; Weight of Residual in Sublayer, Lateral (non-WET Bed) portion of Bed Sediment Reservoir. (SLRSIDW + SLRSLAT = Total Residual assigned to RSIDW() in the Inactive Layer.)

SLUE = Subroutines slue determines when to skip to a new page and prints column headings.

SOBC() = Storage array; local; The outflowing sediment discharge computed for the downstream boundary of each segment of the network is stored in SOBC.

SOND = Global, Scalar.

SPD = Global, Scalar, Program logic variable. Small Positive Difference

SPGC = Global, Specific Gravity of Clay particles (SEE SGSP and SGSSP).

SPGF = Global, Specific Gravity of Fluid.

SPGR = Local, Colby Function; Specific Gravity of Sand and Larger Particles.

SPGS = Global, Specific Gravity of Sediment Particles (SEE SGSP and SGSSP).

SPI = Specify the number of integration intervals to be used in solving Exner Equation.

SPV = Global, Scalar. Program logic variable. Small positive Value.

SQRT = An intrinsic Fortran library subroutine for extracting square roots.

SRFEL = Global, Array.

SSE = Global, Array.

SSSQ = Global, Array.

STA = Cross section stations dividing the section into subsections for calculating hydraulic elements.

STCD = Global, Scalar. Bed Shear Stress Threshold for the deposition of clay.

STENCL = Local, Scalar. Station of Encroachment, Left Side of Cross Section. Together with ELENCL this variable inserts an encroachment into the cross section. Before Version 5, this variable was synonymous with STST if ELENCL was blank. However, beginning Aug 6, 1997, Version 5 was modified to automatically block out the cross section up to the maximum depth even if ELENCL were blank. That is to take advantage of this option by inserting points into the cross section so

the depth of water is added to the wetted perimeter up the face of the encroachment. (SEE STST and STENCR below.)

- STST = Global, Scalar. Station to Start computations, Left Side of Cross Section. All stations less than STST are ignored. STST does not insert points into the cross section; consequently, the depth of water is not added to the wetted perimeter at STST. (SEE ENST for Ending Station)
- STENCR = Local, Scalar. Station of Encroachment, Right Side of Cross Section. (SEE STENCL for details.)
- STMOD2 = Subroutine STMOD2 reads sediment input data.
- SUBLAY(NXSA,NGS) = Global; Sediment weights in the WET portion of the Sublayer, Bed Sediment Reservoir.
- TCH = 0.
- TIMZDR( ) = Computation array, Time of settling of dredged disposal material which falls back into the water column.
- TLHA = **OBSELETE.** Global, Total allowable head difference between cutoff and mainstem energy line in the program patch developed for Nashville District's analysis of a flood protection plan at ? on the Cumberland River. (aprx 1988)
- TLHP = (See TLHA)
- TOG = Two times the acceleration of gravity.
- TQSH(I)=0.
- TRD = TWO/3.
- TWO = 2.
- UWSCA() = Global, Initial specific weight of sediment deposits by size class, tons/cubic foot.
- UWSC(I) = Global, Fully Compacted specific weight of sediment deposits by size class, tons/cubic foot. (CLAY= PUCDLB/TON; SILT= PUSDLB/TON; SAND AND LARGER = UWDLB/TON))
- VCL = Local; Volume of clay currently in the bed sediment reservoir.
- VNM = Local; Total volume of non-cohesive sediment currently in the bed sediment reservoir. (i.e. sand, gravel, cobbles, boulders)
- VOL = Local; Total volume of sediment currently in the bed sediment reservoir.
- VSL = Local; Volume of silt currently in the bed sediment reservoir.
- WAL = Global, Total weight of all deposits in the Active Layer.
- WCDA = Global, Total weight of clay deposits in the Active Layer.
- WCDI = Global, Total weight of clay deposits in the Inactive Layer.

WCDS = Global, Total weight of clay deposits in the Sublayer.

WIL = Global, Total weight of all deposits in the Inactive Layer. (The Residual Deposits, i.e. those beyond the portion of the bed gradation curve in this model, is not included.)

WMBK() = Computational array, Weight of sediment material in the model bottom, Conveyance portion of the Cross Section.

WMBS() = Computational array, Weight of sediment material in the model bottom, Storage portion of the Cross Section.

WS() = Computational array, Water Surface Elevation during the computation of the water surface profile.

WSCP() = Storage Array, Water Surface Elevation at each Control Point.

WSDA = Global, Total weight of silt deposits in the Active Layer.

WSDI = Global, Total weight of silt deposits in the Inactive Layer.

WSDS = Global, Total weight of silt deposits in the Sublayer.

WSNA = Global, Total weight of sand and larger sediment particles in the Active Layer.

WSNI = Global, Total weight of sand and larger sediment in the Inactive Layer. Includes the weight of Residual sediment if present.

WSNS = Global, Total weight of sand and larger sediment in the Sublayer.

WSP() = Storage Array, Calculated water surface elevation at each cross section.

WSR() = Input array, Water Surface elevation(s) at the Downstream Control point(s) of the model network. (i.e. the Base Level)

WT() = Global, Water Temperature.

WTARAY()= Computational array, Global, Water Temperature at each cross section.

WTLOC() =Global, Computational array; Water temperature for the Local Inflow/Outflows

XDMIX = MODELING VARIABLE, Global, The number of channel widths over which water flows before local inflows are mixed with the main stem concentrations. Applied to each local inflow. The value is assumed to be 20. It can be changed with input data.

XLOC(i,j) = Global, Storage array; The independent variable when prescribing local inflow/outflow by percent or head relationships rather than simply prescribing the Q. (i.e. It is the QSEQ in QSEG vs Percent Local outflow tables; It is the H in Head vs Local outflow tables. SEE YLIP)

XMLOOP(L) = Calculation Array, Global; The solution of the closed loop problem requires two straight lines. The general form of the equations is  $y = mX + B$ . XMLOOP is the "m" Coefficient in that solution. (SEE BLOOP)

YLOC(i,j) = Global, Storage array; The dependent variable when prescribing local inflow/outflow by percent or head relationships rather than simply prescribing the Q. (i.e. It is the PERCENT in QSEG vs Percent Local outflow tables; It is the Q in Head vs Local outflow tables. SEE XLIQ)



## **APPENDIX C**

### **INPUT DATA EXAMPLES**



## INPUT DATA EXAMPLES

### Introduction

The network structure and data components forming the input data file are described. Then, example input files are presented for the single segment problem, the tree branch network, the distributary network and the island flow-distribution network.

### Network Structure

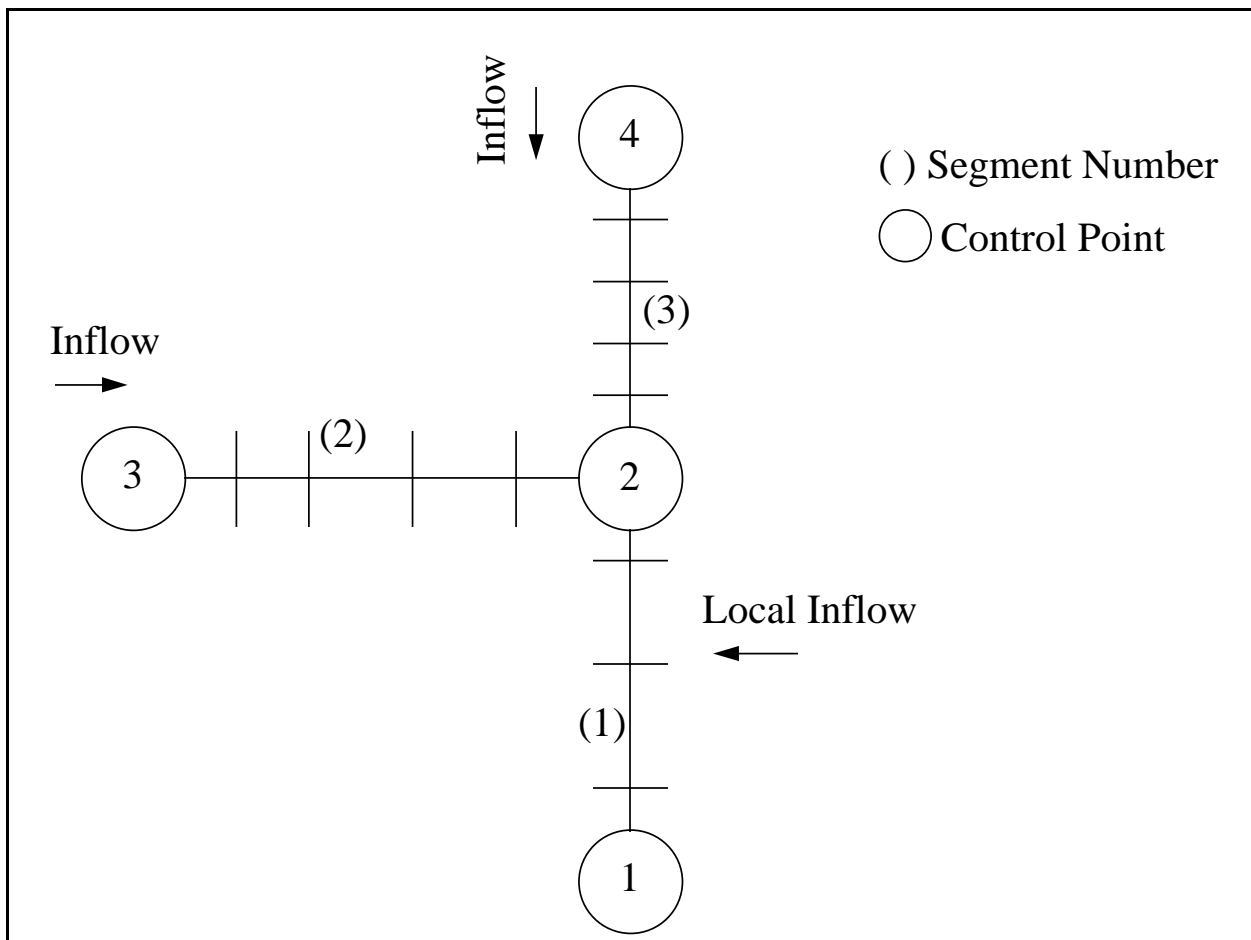

**Figure C-1. A Stream Network Consisting of One Junction and One Local Inflow Point.**

Network structure refers to the plan view of streams in a drainage basin. It is useful to depict a network structure using a stick diagram as illustrated in Figure C-1. Each junction of a main stem channel with a

tributary is represented by a circle. The link between junctions is represented by a line segment. The junction points are called control points and the lines are called segments.

Single segment models coded for the Hydrologic Engineering Center's library version of HEC-6, hereafter referred to as simply the **Library Version**, will also run in HEC-6T without changing the data. The network structure is assumed, by the program, to be control points one and two connected by segment one. Control point one is assumed to be the downstream end and control point two the upstream end of the model.

Tree branch networks coded for the library Version of HEC-6 using \$TRIB and CP Records to link the segments together will also run in HEC-6T without changing the geometric data or the hydrologic data. However, it will be necessary to re-structure the sediment data sets into the HEC-6T Data Structure. Also, it will be essential to code the control points for each end of each segment on its CP Record as described in Appendix E of this document, "Input Description for Geometry and Channel Properties." CP numbers in the library version can be omitted, and the program logic would make assumptions and proceeded. However, HEC-6T needs the CP numbers.

Examples 1 through 6 are coded in the Library Version. However, when running data files coded for the Library Version of HEC-6 always review how the computer has assigned water discharges and water temperatures by requesting an A-Level printout in Hydraulic Calculations. (See the \* Record in the "Input Description for Hydrologic Data," Appendix G in this document. Search for the either /HYD-1/ or /NETWORK WATER DISCHARGES AND TEMPERATURES/.

A \$SEG-Record in the Geometric Data will convey to the computer to link the branches of a Network together using the HEC-6T data structure. This document will refer to the \$SEG linkage as the **HEC-6T** Data Structure.

The HEC-6T data structure is required for networks having distributaries or closed loops. However, it is preferred for all data sets since all new capability is tested with data sets coded only in the HEC-6T Data Structure.

HEC-6T will read geometry in the LRD-1 format.

## **Geometric Data**

Coding instructions for existing, HEC-6, Record types will not change. How the Individual Segments are laced together to form the Network is **new**. Table C-1 illustrates the VERSION 4.00 Data Structure for the Geometric Model.

### **NOTICE:**

The most significant, structure difference between VERSION 4.00 and data sets for earlier versions of

```

T1 Lower Atchafalaya River from Gulf to Wax Lake Outlet Structure
T2 ...
T3 ...
NC ...
X1 ... etc
EJ
$SEG      3      3      2
T1Wax Lake Outlet from Gulf to Wax Lake Outlet Structure
T2 ...
T3 ...
NC ...
X1 ... etc
EJ
$SEG      2      4      4
T1 Atchafalaya Floodway U/S from Wax Lake Outlet Structure
T2 ...
T3 ...
NC ...
X1 ... etc
EJ

```

## Sediment Data

Coding instructions for existing Record types will not change. How the Individual Segments are laced together to form the Network is what is **new**. Table C-2 illustrates the VERSION 4.00 Data Structure for the Sedimentary Data Set.

### NOTICE:

The \$TRIB and CP Records are replaced by the \$SEG-Record. Place the \$SEG-Record before each sediment data after the first segment. However:

Do not put a \$SEG-Record before the sediment data set for segment number 1.

The \$Local Record is still required if local inflows are present.

TABLE C-2. SEDIMENT DATA

```

T4      Lower Atchafalaya River from Gulf to Wax Lake Outlet Structure
T5      Sediment Data
T6 ...
T7 ...
T8 ... etc
I1
I2
I3
I4
CP      2
LQ      DISTRIBUTION COEFFICIENTS FOR DISTRIBUTARY.
SD      This table will be applied at Junction 2 (U/S Junction)
SD      1 SD-Record for each grain size.
SD      This value will be multiplied times approaching
SD      sediment concentrations to determine how much of the
SD      total C passes into the Lower Atchafalaya River.
SD
PF      Bed Gradation for L Atch River
PFC     Code up to 20 points as needed to model the PF curve
CP No   CP No   Segment

```

```

D/S      U/S      No
$SEG      3        2        2
T4        Wax Lake Outlet from Gulf to Wax Lake Outlet Structure
T5 ...
T6 ...
T7...
T8...    Do not include I RECORDS.  Values from above will be used.
PF        Code PF-Records for Wax Lake outlet bed gradation.
PFC       and Continue on PFC-Records as needed
$SEG      3        4        3
T4        Sediment Data for the Atchafalaya River U/S of Wax Lake
T5        5 Title records are required, T4-T8
T6 ...
T7 ...
T8 ... etc
CP      4    The following Sediment Boundary Condition are for Control Point 4
LQ      Inflowing Sediment Concentrations for Atchafalaya Floodway

LT      Code same as HEC-6 Load Curves;
LF      .
LF      .
LF      .
LF      Code 1 LF-Record for each size class
LF
LF
PF      Bed Gradation in Atchafalaya Floodway
PFC     Code up to 20 points per PF curve using the PFC-Records for
        conuation

```

## Hydrologic Data

**General.** Hydrology for VERSION 4.00 is vastly different from HEC-6 and some versions of HEC-6 used by WES. HEC-6T assigns a water discharge to each cross section in the data set as shown in column 5 of table HYD-1. This table is obtained by selecting the A-Level printout in Hydraulics Calculations. Instructions for selecting print-out are shown on the \* Record in the Hydrologic Data Set, Appendix G.

TABLE HYD-1. NETWORK WATER DISCHARGES AND TEMPERATURES.

SEGMENT	7	1 ( WSU/S	S	XSAS	S	( WSU/S	S	K WATES	S	W WATES	S.)TT*(	O ES	S SECTRSIONO
1	3	3	16680.0	5-600.0	450.0	S.							
2	1	4	26680.0	2-600.0	450.0	S.							
2	2	1(	2668189	2-600.0	450.0	S.)TT*(	2		3				
3	1	-	2-0.0	3-600.0	450.0	S.							
3	2	9	2-189	3-600.0	450.0	S.							
3	3	10	2-379	3-600.0	450.0	S.							
3	4	11	2-568	3-600.0	450.0	S.							

B. Junction-to-Cross-Section Connections are established by the program when the geometric data set is read. The Geometry Module also assigns a Boundary Condition Type Number to each Control Point. The default logic is

- TYPE = 1 for an External Control Point at the D/S end of a segment,
- TYPE = 4 for an Internal Junction Control Point, and
- TYPE = 3 for an External Control Point at the U/S end of a segment.

The results are printed in Table GEO-3 at the end of all Geometric Data Printout.

TABLE GEO-3. NETWORK STRUCTURE.

SEGMENT NO	DOWNSTREAM NUMBER	CONTROL POINT TYPE	UPSTREAM NUMBER	CONTROL POINT TYPE	LOCAL INFLOW POINTS		
					QT	QP	QL
1	1	1	2	4	1	0	0
2	2	4	3	3	0	0	0
3	2	4	4	3	0	0	0

**Network Structure.** Coding the water inflows for a stream network is illustrated below. This simple network, shown in Figure C-1, is a main channel with one tributary. It has one local inflow point, and it is located, by the position of the QT Record, in Segment 1 between the second and third cross sections. The local inflow will enter the model in that reach. Each external control point is either an inflow point or an outflow point. In this example there are two inflow points, nos 3 and 4, and one outflow point, number 1.

**Coding the Q Record.** The position of flows across the Q Record is dictated by the network structure. The actual water discharge is prescribed on the Q Records after the \$HYD-Record. The general rule for coding the Q Record is to start with the most downstream local on Segment 1 and code the water discharges by moving in the upstream direction along each segment. Upon reaching the next segment, continue coding across the Q Record without skipping a field. If there is only one segment in the model, the last value coded is the main stem water discharge entering the upstream end of the segment.

In a stream network there will always be more than one segment. Therefore, the only possible external inflows to segment 1 are locals inflows. The water discharge at the downstream end of a segment will be calculated by the program. Therefore, start coding with the most downstream local. If there are no local inflow points on Segment 1, move up the network to segment 2. Upon reaching an external boundary point at the upstream end of a segment, code that discharge on the Q Record.

**Example.** The complete data set for the network in Figure C-1 is shown in EXAMPLE 14 later in this appendix. A portion of that data set is reproduced here to illustrate the coding procedure:

```

$SEG 1 2 1
T1 EXAMPLE NO. 14. ONE LOCAL AND 1 JUNCTION, CODED IN V4.00 SYNTAX
T2 MBH-1 VERSION 4.00. 21 AUG 1994, WA THOMAS
T3
NC .150 .150 .015 .3 .1
X1 800 4 3373.49 3430.49 0 0 0
X3 10
GR 5600 3373.49 5560 3393.49 5560 3400.49 5600 3430.49
H 800
X1 1160 4 3063.53 3123.53 3600 3600 3600
X3 10
GR 5600 3063.53 5565 3068.53 5565 3073.53 5600 3123.53
H 1160
QT
X1 1660 4 2612.34 2616.34 5000 5000 5000
X3 10
GR 5600 2608.34 5568 2612.34 5568 2712.34 5575 2716.34 5600 2750
H 1660

```

```

EJ
$SEG 2 3 2
T1+ EXAMPLE 14. ONE LOCAL AND 1 JUNCTION, SEGMENT 2
T2 MBH-1 VERSION 4.00. 21 AUG 1994, WA THOMAS
.
.
.
$HYD
* AB RUN 1
Q 1000 2000 3000
R 5580.00
T 45. 45 45
W .1

```

**In summary**, the procedure is to start with the most downstream inflow point and code water discharge inflows consecutively across the Q Record until the most upstream value is reached. If more than ten values are required, continue in field one of the next Q Record.

The first water discharge, 1000 cfs, is the local inflow. The second water discharge on the Q Record, 2000 cfs, is the mainstream inflow for Segment 2 in the Network. The Third water discharge on the Q Record, 3000 cfs, is the mainstream inflow for Segment 3.

Table HYD-1, above, shows how the program distributes the inflows to each cross section in the network. Note the segment number in column 1. The local inflow enters the model in segment 1 between cross sections 2 and 3. Column 6 of Table HYD-1 shows the water discharge to be 6000 cfs at cross sections 1 and 2, and the water discharge changes to 5000 cfs at cross section 3. That reflects the local inflow.

Note that segment 2 in table HYD-1 has a water discharge of 2000 cfs at each cross section. That comes from field 2 of the Q Record. Likewise, Field 3 of the Q Record provided the mainstream inflow for Segment

## Boundary Conditions

Boundary conditions is used in the mathematical sense. It refers to the class of problems in which there are more unknowns than equations, and that is the case when doing open channel flow and sedimentation modeling. In these problems the boundary conditions are the

inflowing water,  
inflowing sediment, and  
downstream water surface elevation.

The water and sediment enter the model at the upstream end. In subcritical flow, the base level of energy (i.e. downstream water surface elevation) is controlled at the downstream end of the model. Since HEC-6T is a sub-critical flow model, it expects these boundary values to be prescribed as stated here. The model then calculates the response to these boundary conditions at all cross sections. The inflowing water discharge and the downstream water surface elevation are prescribed in the Hydrologic Data Set. The inflowing sediment discharge is prescribed by a sediment rating table in the Sedimentary Data Set (See Table C-2). The model determines the sediment inflow for each water discharge by interpolating from the sediment rating table.

TABLE C-3. HYDROLOGIC DATA

```

$HYD
$CL  55      1      REM:LOWER ATCHAFALAYA RIVER SEGMENT (1) EST TO GET 55%
*    AB      The comment record is the same as past HEC-6
Q    3000    Prescribe the inflowing water inflow at CP 4
$WSCP 1      3      Control Pt#s, Gulf End of LAR and Wax Lake Outlet Brs
R     7      7      Gulf Elevation for Control Points 1 & 3
T     65      Water Temperature, inflow at CP 4
W     1      Duration of this event in Days
*    B EVENT #2
Q     5000
W     1
*    B EVENT #3
Q    10000
R     6      6
W     1
.
.
.
$$END

```

## Examples

The following are example input data sets. They are provided to aid in interpreting the data requirements. The T1 Records are collected into the table of contents at the beginning of this appendix.

Each example has a sketch that shows the network configuration. The circles are Control Points at the downstream end and upstream end of the segment, Numbers 1 and 2, respectively. The segment number is shown in parenthesis.

The following examples are provided to aid in interpreting the data requirements.

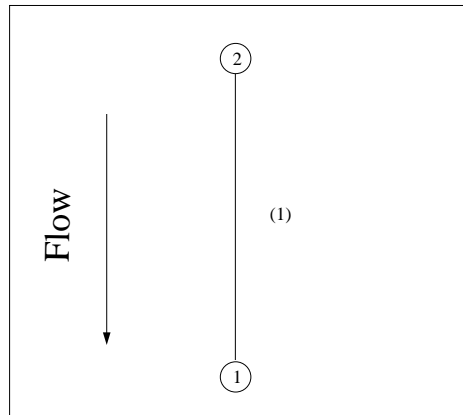

Figure C-2. EXAMPLE NO. 1. SIMPLE TEST USING P-RECORD MODEL EXTENSION. NO LOCALS

```

T1      EXAMPLE NO. 1. SIMPLE TEST USING P-RECORD MODEL EXTENSION. NO LOCALS
T2      HEC-6T VERSION 4.00. 4 MARCH 1994, WA THOMAS
T3
NC      .150      .150      .025
X1      10        6        -4.1      4.1      0        0        0
X3      10
GR      4        -5        4        -4.1      0        -4        0        4        4
4.1
GR      4        5
H       10
PX      10        4        .0002      1000
EJ
T4      EX. NO. 1 SEDIMENT DATA FOR SIMPLE MODEL. TEST TOFFALETI
T5      BED GRADATION ARE HYPOTHETICAL
T6      SEDIMENT INFLOW IS 0.0
T7
T8
I1      10
I4      1        1        5
LQ      Q        10      30000.
LC      MG/L
LF      VFS
LF      FS
LF      MS
LF      CS

```

```

LF   VCS
PF           1.0      2      1      36.0      0.5      31.0      .25
28.0
PFC .125     10     .0625     0
$HYD
*   AB      RUN 1
Q   2000
R   3.0
T   45.
W   .1
$$END

```

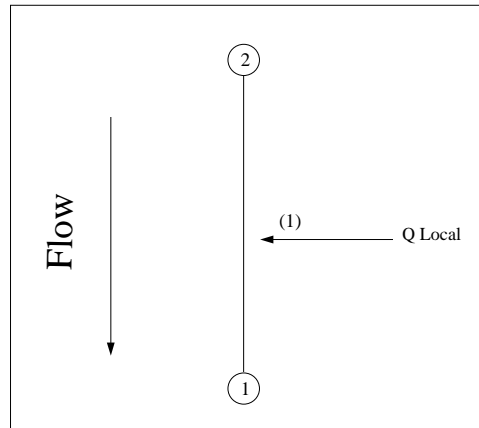

Figure C-3. EXAMPLE

NO. 2. TEST LOCAL INFLOW OPTION

```

T1      EXAMPLE NO. 2.  TEST LOCAL INFLOW OPTION
T2      HEC-6T  VERSION 4.00.    4 MARCH 1994,    WA THOMAS
T3
NC
NV      11      .150
NV      21      .025
NV      31      .150
X1      800     25  3373.49  3631.46      0      0      0
X3      10
GR5577.6  3100.23  5578.9  3113.0  5578.1  3291.29  5578.6  3322.26  5578.26
3350.49
GR5578.6  3373.49  5571.4  3393.49  5570.06  3400.49  5569.2  3410.49  5568.6
3430.49
GR5568.6  3450.49  5569.2  3490.49  5569.5  3500.49  5569.4  3510.49  5569.8
3530.49
GR5570.8  3540.49  5572.0  3560.49  5572.5  3569.49  5574.9  3580.49  5575.3
3590.49
GR5576.3  3600.49  5577.3  3627.49  5577.2  3631.46  5576.5  3681.22  5576.5
3681.32
H       800
X1      1160     25  3073.53  3308.53      360     360     360
X3      10
GR5575.5  3063.53  5576.4  3068.53  5578.08  3073.53  5569.6  3113.53  5569.1
3123.53
GR5569.2  3133.53  5568.9  3143.53  5569.1  3153.53  5570.9  3183.53  5571.5
3203.53

```

GR5571.8	3233.53	5572.3	3243.53	5572.3	3248.53	5572.1	3253.53	5571.5	
3258.53									
GR5570.8	3263.53	5571.7	3273.53	5572.2	3277.53	5572.5	3278.53	5575.18	
3290.53									
GR5576.6	3296.53	5577.2	3308.53	5576.8	3321.53	5576.9	3385.93	5576.9	
3441.4									
H	1160								
X1	1660	10	2582.34	3020.34	500	500	500		
X3	10								
GR5577.5	2286.19	5578.5	2582.34	5577.78	2585.34	5577.8	2592.34	5577.62	
2602.34									
GR5580.7	3018.34	5580.8	3020.34	5578.3	3029.08	5580.6	3042.35	5580.5	
3055.69									
H	1660								
QT	1								
X1	1960	15	2857.84	3291.27	300	300	300		
X3	10								
GR5582.0	2750.39	5579.1	2768.72	5579.1	2771.91	5578.9	2847.84	5578.9	
2857.84									
GR5578.3	3262.84	5580.8	3271.84	5581.29	3276.84	5581.8	3291.27	5581.7	
3308.30									
GR5582.2	3329.02	5586.1	3355.42	5586.6	3371.5	5582.2	3392.08	5581.8	
3398.70									
H	1960								
X1	2220	10	2745.72	3053.72	260	260	260		
X3	10								
GR5575.9	2698.72	5577.0	2702.72	5577.9	2722.72	5577.1	2732.72	5577.09	
2745.72									
GR5569.1	3012.72	5568.8	3022.72	5579.2	3053.72	5587.0	3175.03	5586.8	
3184.7									
H	2220								
NC			.025						
EJ									
T4	EX. NO. 2 SEDIMENT DATA FOR LOCAL INFLOW TEST								
T5	BED GRADATION ARE HYPOTHETICAL								
T6	SEDIMENT INFLOW IS HYPOTHETICAL								
T7									
T8									
I1		10							
I4		14	1	11					
LQ	Q	10	30000.						
LTLTOTAL									
LF	VFS								
LF	FS								
LF	MS								
LF	CS								
LF	VCS								
LF	VFG								
LF	FG								
LF	MG								
LF	CG								
LF	VCG								
LF	SC								
PF		800	1.0	128.0	64.0	36.0	32.0	31.0	16.0
28.0									
PFC	8.0	27.0	4.0	25.0	2.0	24.0	1.0	19.0	.50
16.0									
PFC	.250	15.0	.125	13.0					
\$LOCAL									
LQL		-5000	-1	1	5000				
LCLTOTAL				100	100				
LFL	VFS	1	1	.3	.3				

LFL	FS	.1	.1	.2	.2
LFL	MS	0	0	.1	.1
LFL	CS	0	0	.05	.05
LFL	VCS			.05	.05
LFL	VFG			.05	.05
LFL	FG			.05	.05
LFL	MG			.05	.05
LFL	CG			.05	.05
LFL	VCG			.05	.05
LFL	SC			.05	.05
\$HYD					
\$SED					
*	AB	RUN	1		
Q	2000		500		
R	5578				
T	45		50		
W	.1				
\$SED					
LRATIO		1	0	2	
END					
*	AB	RUN	1		
Q	2000		500		
W	.1				
\$\$END					

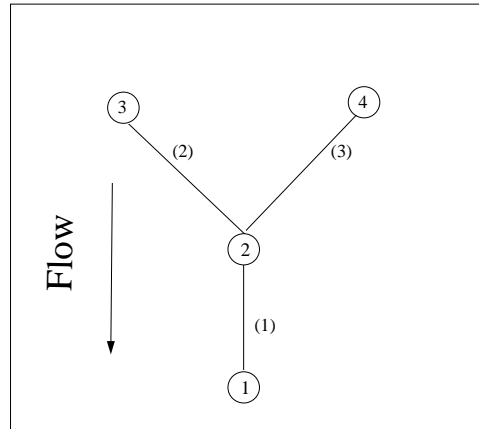

Figure C-4. EXAMPLE NO. 3. TEST 3 BRANCHES WITH 1 JUNCTION

```

$SEG 1 2 1
T1 EXAMPLE NO. 3. TEST 3 BRANCHES WITH 1 JUNCTION
T2 HEC-6T VERSION 4.00. 4 MARCH 1994, WA THOMAS
T3
NC .150 .150 .025 .3 .1
X1 10 5 3373.49 3430.49 0 0 0
X3 10
GR5578.6 3373.49 5571.4 3393.49 5570.06 3400.49 5569.2 3410.49 5568.6
3430.49
H 10
PX 3 .000 1000
EJ
$SEG 2 3 2
T1+ SEGMENT 2 4-X-SEC AT 0 SLOPE
T2
T3
NC .150 .150 .025 .3 .1
X1 20 5 3373.49 3430.49 0 0 0
X3 10
GR5578.6 3373.49 5571.4 3393.49 5570.06 3400.49 5569.2 3410.49 5568.6
3430.49
H 20
PX 3 .000 1000
EJ
$SEG 2 4 3 T1+ SEGMENT 3 4-X-SEC AT 0 SLOPE
T2
T3
NC .150 .150 .025 .3 .1
X1 30 5 3373.49 3430.49 0 0 0
X3 10
GR5578.6 3373.49 5571.4 3393.49 5570.06 3400.49 5569.2 3410.49 5568.6
3430.49
H 30
PX 3 .000 1000
EJ
T4 EX. NO. 3 SEDIMENT DATA FOR SINGLE JUNCTION TEST. SEGMENT 1/3
T5 BED GRADATION ARE HYPOTHETICAL
T6 SEDIMENT INFLOW IS HYPOTHETICAL
T7

```

```

T8
I1          10
I4          14          1          2
PF          10          1.0      128.0    64.0    36.0    32.0    31.0    16.0
28.0
PFC 8.0     27.0     4.0     25.0     2.0     24.0     1.0     19.0     .50
16.0
PFC .250    15.0     .125    13.0
$SEGS      2      3      2
T4+        EX. NO. 3  SEDIMENT DATA FOR SINGLE JUNCTION TEST.  SEGMENT 2/3
T5          BED GRADATION ARE HYPOTHETICAL
T6          SEDIMENT INFLOW IS HYPOTHETICAL
T7
T8
CP          3
LQ          1      50000
LC          1      2
LF          .8     .8
LF          .2     .2
PF          20     1.0     128.0    64.0    36.0    32.0    31.0    16.0
28.0
PFC 8.0     27.0     4.0     25.0     2.0     24.0     1.0     19.0     .50
16.0
PFC .250    15.0     .125    13.0
$SEGS      2      4      3
T4+        EX. NO. 3  SEDIMENT DATA FOR SINGLE JUNCTION TEST.  SEGMENT 3/3
T5          BED GRADATION ARE HYPOTHETICAL
T6          SEDIMENT INFLOW IS HYPOTHETICAL
T7
T8
CP          4
LQ          1      50000
LC          1      2
LF          .8     .8
LF          .2     .2
PF          30     1.0     128.0    64.0    36.0    32.0    31.0    16.0
28.0
PFC 8.0     27.0     4.0     25.0     2.0     24.0     1.0     19.0     .50
16.0
PFC .250    15.0     .125    13.0
$HYD
*  AB  RUN  1
Q   2000  1000  1000
R 5575.00
T   45.   45   45
W   .1
$$END

```

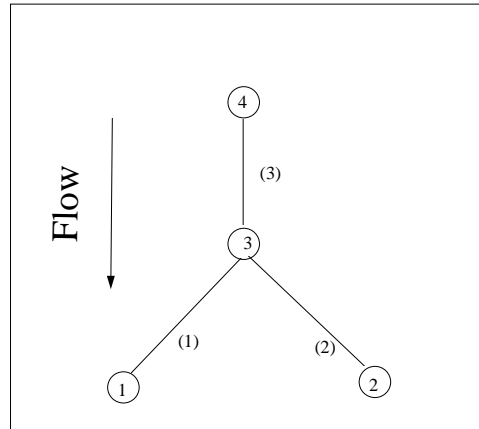

Figure C-5. EXAMPLE NO. 7. WAX LAKE OUTLET DISTRIBUTARY... LOWER ATCH RIV SEGMENT

```

$SEG 1 3 1
T1 EXAMPLE NO. 7. WAX LAKE OUTLET DISTRIBUTARY... LOWER ATCH RIV SEGMENT
T2 HEC-6T VERSION 4.00. 15 JUNE 1994, WA THOMAS
T3
NC .150 .150 .025 .3 .1
X1 10 7 3373.49 3430.49 0 0 0
X3 10
GR5578.6 3373.49 5571.4 3393.49 5570.06 3400.49 5569.2 3410.49 5568.6
3430.49
GR 5577 3440 5578 6000
H 10
PX 10 .000 2000
EJ
$SEG 2 3 2
T1+ EX NO. 7. WAX LAKE OUTLET DISTRIBUTARY TEST... WAX LAKE SEGMENT
T2 HEC-6T VERSION 4.00. 15 JUNE 1994, WA THOMAS
T3
NC .150 .150 .025 .3 .1
X1 20 5 3373.49 3430.49 0 0 0
X3 10
GR5578.6 3373.49 5571.4 3393.49 5570.06 3400.49 5569.2 3410.49 5568.6
3430.49
H 20
PX 5 .000 1000
EJ
$SEG 3 4 3
T1+ EX NO. 7. WAX LAKE OUTLET DISTRIBUTARY TEST... UPPER ATCH. BASIN CH.
T2 HEC-6T VERSION 4.00. 15 JULY 1994, WA THOMAS
T3
NC .150 .150 .025 .3 .1
X1 30 5 3373.49 3430.49 0 0 0
X3 10
GR5578.6 3373.49 5571.4 3393.49 5570.06 3400.49 5569.2 3410.49 5568.6
3430.49
H 30
PX 4 .000 1000
EJ
T4 EX. NO. 7 SEDIMENT DATA FOR WAX LAKE DISTRIBUTARY TEST. SEGMENT 1/3
T5 BED GRADATION ARE HYPOTHETICAL

```

```

T6      SEDIMENT INFLOW IS HYPOTHETICAL
T7
T8
I1          10
I4          14      1      2
PF          10      1.0    128.0    64.0    36.0    32.0    31.0    16.0
28.0
PFC 8.0     27.0     4.0     25.0     2.0     24.0     1.0     19.0     .50
16.0
PFC .250    15.0     .125    13.0
$SEGS 2      3      2
T4+      EX. NO. 7  SEDIMENT DATA FOR WAX LAKE DISTRIBUTARY TEST.  SEGMENT 2/3
T5      BED GRADATION ARE HYPOTHETICAL
T6      SEDIMENT INFLOW IS HYPOTHETICAL
T7
T8
CP       3      1
LQ          1     5000.
SD  VFS     .8     .8
SD   FS      0     1
PF          20     1.0    128.0    64.0    36.0    32.0    31.0    16.0
28.0
PFC 8.0     27.0     4.0     25.0     2.0     24.0     1.0     19.0     .50
16.0
PFC .250    15.0     .125    13.0
$SEGS 3      4      3
T4+      EX. NO. 7  SEDIMENT DATA FOR WAX LAKE DISTRIBUTARY TEST.  SEGMENT 3/3
T5      BED GRADATION ARE HYPOTHETICAL
T6      SEDIMENT INFLOW IS HYPOTHETICAL
T7
T8
CP       4
LQ          1     50000
LC          1     2
LF          .8     .8
LF          .2     .2
PF          30     1.0    128.0    64.0    36.0    32.0    31.0    16.0
28.0
PFC 8.0     27.0     4.0     25.0     2.0     24.0     1.0     19.0     .50
16.0
PFC .250    15.0     .125    13.0
$HYD
$CL      70
$SED
LP          2     0     2     1
LQ          1     5000
SD  VFS     0     0
SD  FS      1     1
*  AC  RUN 1
Q    3000
$WSCP 1     2
R 5575.0   5576.
T    45
W    1
*  AB  RUN 2
Q    3000
W    1
$$END

```

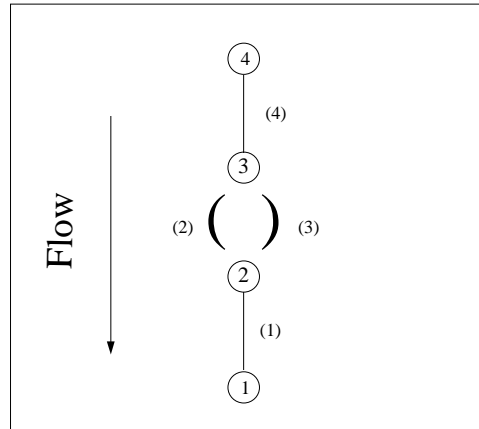

Figure C-6. EXAMPLE NO. 8. TEST ISLAND FLOW CALCULATION. SEGMENT 1= D/S FROM ISLAN

```

$SEG 1 2 1
T1 EXAMPLE NO. 8. TEST ISLAND FLOW CALCULATION. SEGMENT 1= D/S FROM
ISLAN
T2 HEC-6T VERSION 4.00. 1 MAY 1994, WA THOMAS
T3
NC .150 .150 .025 .3 .1
X1 10 4 0 500 0 0 0
GR 50 0 0 50 0 450 50 500
H 10
PX
EJ 4 .000 1000
$SEG 2 3 2
T1+ EX NO. 8. TEST ISLAND FLOW CALCULATION. SEGMENT 2 = AROUND ISLAND
T2 HEC-6T VERSION 4.00. 1 MAY 1994, WA THOMAS
T3
NC .150 .150 .025 .3 .1
X1 20 4 0 500 0 0 0
GR 50 0 0 50 0 450 50 500
H 20
PX
EJ 4 .000 2000
$SEG 2 3 3
T1+ EX NO. 8. TEST ISLAND FLOW CALCULATION. SEGMENT 3 = AROUND ISLAND
T2 HEC-6T VERSION 4.00. 1 MAY 1994, WA THOMAS
T3
NC .150 .150 .025 .3 .1
X1 31 4 0 500 0 0 0
GR 50 0 0 50 0 450 50 500
H 31
X1 32 4 0 500 1000 1000 1000
GR 50 0 0 50 0 450 50 500
H 32
X1 33 4 0 500 1000 1000 1000
GR 50 0 0 50 0 450 50 500
H 33
X1 34 4 0 500 1000 1000 1000
GR 50 0 0 50 0 450 50 500
H 34
QT

```

X1	35	4	0	500	1000	1000	1000	
GR	50	0	0	50	0	450	50	500
H	35							
X1	36	4	0	500	1000	1000	1000	
GR	50	0	0	50	0	450	50	500
H	36							
EJ								
\$SEGS	3	4	4					
T1+	EX NO. 8. TEST ISLAND FLOW CALCULATION. SEGMENT 4 = U/S FROM ISLAND							
T2	HEC-6T VERSION 4.00. 1 MAY 1994, WA THOMAS							
T3								
NC	.150	.150	.025	.3	.1			
X1	40	4	0	500	0	0	0	
GR	50	0	0	50	0	450	50	500
H	40							
PX						4	.000	1000
EJ								
T4	EX. NO. 8 SEDIMENT DATA FOR ISLAND FLOW TEST. D/S SEGMENT = 1/4							
T5	BED GRADATION ARE HYPOTHETICAL							
T6	SEDIMENT INFLOW IS HYPOTHETICAL							
T7								
T8								
I1		10						
I4		14	1	2				
PF		10	1.0	8.0	.50	96.0	.0625	0
\$SEGS	2	3	2					
T4+	EX. NO. 8 SEDIMENT DATA FOR ISLAND FLOW TEST. D/S SEGMENT = 2/4							
T5								
T6								
T7								
T8								
PF		20	1.0	8.0	.50	96.0	.0625	0
\$SEGS	1	3	3					
T4+	EX. NO. 8 SEDIMENT DATA FOR ISLAND FLOW TEST. D/S SEGMENT = 3/4							
T5								
T6								
T7								
T8								
PF			1.0	8.0	.50	96.0	.0625	0
\$LOCAL								
LQ	OUT	-50000	-1					
LC		1	1					
LF		1	1					
LF		1	1					
\$SEGS	3	4	4					
T4+	EX. NO. 8 SEDIMENT DATA FOR ISLAND FLOW TEST. D/S SEGMENT = 4/4							
T5								
T6								
T7								
T8								
CP	4							
LQ		1	50000					
LC		1	2					
LF		.8	.8					
LF		.2	.2					
PF		40	1.0	8.0	.50	96.0	.0625	0
\$HYD								
\$CL	50	2						
* AC RUN	1							
Q	-500	10000						
R	10							
T	45	45						

```
W      1
*     AB  RUN 2
Q    -1000  10000
X      2      1
$$END
```

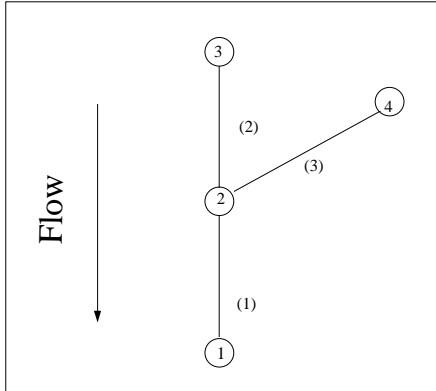

Figure C-7. EXAMPLE  
NO. 14. ONE LOCAL

AND 1 JUNCTION, CODED IN V4.00 SYNTAX

```

$SEG  1      2      1
T1      EXAMPLE NO. 14.  ONE LOCAL AND 1 JUNCTION, CODED IN V4.00 SYNTAX
T2      HEC-6T  VERSION 4.00.  21 AUG 1994,  WA THOMAS
T3
NC  .150    .150    .015    .3    .1
X1  800      4 3373.49 3430.49    0    0    0
X3   10
GR  5600 3373.49    5560 3393.49    5560 3400.49    5600 3430.49
H    800
X1  1160      4 3063.53 3123.53    3600    3600    3600
X3   10
GR  5600 3063.53    5565 3068.53    5565 3073.53    5600 3123.53
H   1160
QT
X1  1660      4 2612.34 2616.34    5000    5000    5000
X3   10
GR  5600 2608.34    5568 2612.34    5568 2712.34    5575 2716.34    5600
2750
H   1660
EJ
$SEG  2      3      2
T1+    EXAMPLE NO. 14.  ONE LOCAL AND 1 JUNCTION, SEGMENT 2
T2      HEC-6T  VERSION 4.00.  21 AUG 1994,  WA THOMAS
T3
NC  .200    .200    .025    .3    .1
X1  2660      4 2612.34 2616.34    5000    5000    5000
X3   10
GR  5600 2608.34    5568 2612.34    5568 2712.34    5575 2716.34    5600
2750
H   2660
PX                                  3    .001    1000
EJ
$SEG  2      4      3
T1+    SEGMENT 3  4-X-SEC AT 0 SLOPE

```

T2									
T3									
NC	.350	.350	.035	.3	.1				
X1	20	5	3373.49	3430.49	0	0	0		
X3	10								
GR5578.6	3373.49	5571.4	3393.49	5570.06	3400.49	5569.2	3410.49	5568.6	
3430.49									
H	20								
PX					3	.000		1000	
EJ									
T4+	EX. NO. 14 SEDIMENT DATA FOR SIMPLE LOCAL PLUS JUNCTION, SEGMENT 1/3								
T5	BED GRADATION ARE HYPOTHETICAL								
T6	NO SEDIMENT INFLOW CURVE SHOULD BE PLACED IN THIS SEGMENT.								
T7	THE LOCAL INFLOW POINT IS IN THIS SEGMENT.								
T8									
I1		10							
I4		14	1	2					
PF		800	1.0	128.0	64.0	36.0	32.0	31.0	16.0
28.0									
PFC	8.0	27.0	4.0	25.0	2.0	24.0	1.0	19.0	.50
16.0									
PFC	.250	15.0	.125	13.0					
\$LOCAL									
LQL	Q	10	20000.						
LCLTOTAL		100	100.						
LFL	VFS	.5	.5						
LFL	FS	.5	.5						
\$SEG	2	3	2						
T4	EX. NO. 14 SEDIMENT DATA FOR SINGLE JUNCTION/LOCAL TEST. SEGMENT 2/3								
T5	SEGMENT 2 IS A CONTINUATION OF SEGMENT 1 PAST THE JUNCTION								
T6	THE SEDIMENT INFLOW LOAD CURVE IS PLACED IN THIS SEGMENT								
T7	A PF RECORD IS REQUIRED IN THIS SEGMENT. IT MUST MATCH THE X1-STATION								
T8									
CP		3							
LQ	Q	10	10000.						
LTLTOTAL		200	200.						
LF	VFS	.5	.5						
LF	FS	.5	.5						
PF		2660	1.0	128.0	64.0	36.0	32.0	31.0	16.0
28.0									
PFC	8.0	27.0	4.0	25.0	2.0	24.0	1.0	19.0	.50
16.0									
PFC	.250	15.0	.125	13.0					
\$SEG	2	4	3						
T4+	EX. NO. 14 SEDIMENT DATA FOR SINGLE JUNCTION/LOCAL TEST. SEGMENT 3/3								
T5	BED GRADATION ARE HYPOTHETICAL								
T6	SEDIMENT INFLOW IS HYPOTHETICAL								
T7									
T8									
CP		4							
LQ		1	30000						
LC		1	2						
LF		.8	.8						
LF		.2	.2						
PF		20	1.0	128.0	64.0	36.0	32.0	31.0	16.0
28.0									
PFC	8.0	27.0	4.0	25.0	2.0	24.0	1.0	19.0	.50
16.0									
PFC	.250	15.0	.125	13.0					
\$HYD									
* AB	RUN	1							
Q	1000	2000	3000						

R	5580.00		
T	45.	45	45
W	.1		
\$\$END			

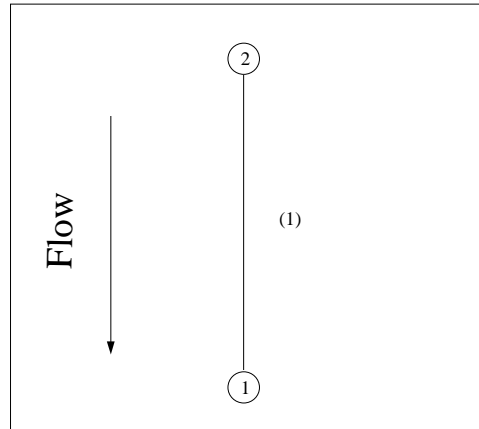

Figure C-8. EXAMPLE  
NO. 19. TEST BED/BANK COMPOSITING AND ENCROACHMENTS, HEC2 FMT.

```

T1      EXAMPLE NO. 19.  TEST BED/BANK COMPOSITING AND ENCROACHMENTS, HEC2
FMT.
T2      WA THOMAS,  31 OCT 94
T3
NV      12      .15      5      .05      40
NV      22      .15      0      .10      10      .05
NV      31      .025
NV      42      .15      0      .10      15      .05
NV      52      .15      10     .035
X1      1        7
X3
XB     -315     -300      300     -400      25      330      500
XC      1        1        1        1        1
GR      5      -800      5      -315      0      -300      0      300      10
330
GR      10      450      30      500
H       1        -400      400
PX
PX      6      .0005
EJ
EJ
T4      EX NO. 19.  SEDIMENT DATA FOR BED/BANK COMPOSITING TEST WITH
ENCROACHM'T
T5      NO SEDIMENT INFLOW
T6      HYPOTHETICAL BED GRADATION
T7
T8
I1      10
I4      13      1      5
LQ      Q      10      50000
LTLTOTAL
LF      VFS
LF      FS
LF      MS
LF      CS
LF      VCS
PF      1      128.0      2.0      86.0      1.0      71.0      .5
58.0
PFC .250      5.0      .0625      3.0
$HYD
$KB      2

```

```
$RE      2
$PLOTTP TITLE=BROWN  ,,,,,,,,,8,9,,,,,,,,15,,,,
*   AB  RUN 1
Q 25000
R   7.00
T   45.
W   .1
*   AB  RUN 2
Q 25000
W   .1
*   AB  RUN 3
Q 25000
W   .1
*   AB  RUN 4
Q 25000
W   .1
*   AB  RUN 5
Q 25000
W   .1
$PLOTTP TITLE=BROWN  ,,,,,,,,,8,9,,,,,,,,15,,,,
$$END
```

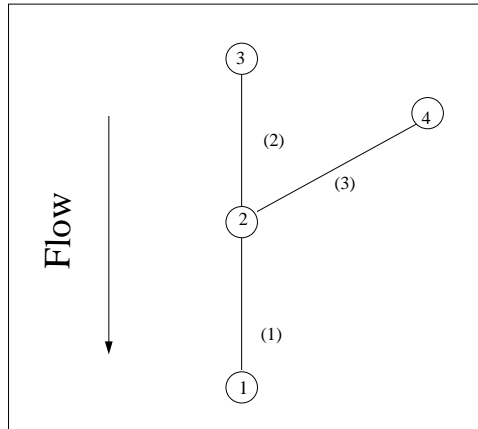

Figure C-9. EXAMPLE  
NO. 26. TEST TWO LOOPS, WET/DRY WITH DREDGING. SEGMENT 1= D/S

```

$SEG 1 2 1
T1+ EXAMPLE NO. 26. TEST TWO LOOPS, WET/DRY WITH DREDGING. SEGMENT 1=
D/S
T2 HEC-6T VERSION 4.00. 1 MAY 1994, WA THOMAS
T3
P .001
NC .150 .150 .025 .3 .1
X1 10 4 0 500 0 0 0
GR 50 0 0 50 0 450 50 500
HI 10 20 -5 200 300 1
PX 1 4 .000 1000
EJ
$SEG 2 3 2
T1+ EX NO. 26. TEST TWO LOOPS. SEGMENT 2 = AROUND
T2 HEC-6T VERSION 4.00. 1 MAY 1994, WA THOMAS
T3
NC .150 .150 .025 .3 .1
X1 20 4 0 500 0 0 0
GR 50 0 0 50 0 450 50 500
HI 20 20 -5 200 300 2
PX 1 4 .000 2000
EJ
$SEG 2 3 3
T1+ EX NO. 26. TEST TWO. SEGMENT 3 = AROUND
T2 HEC-6T VERSION 4.00. 1 MAY 1994, WA THOMAS
T3
NC .150 .150 .025 .3 .1
X1 31 4 0 500 0 0 0
GR 50 0 0 50 0 450 50 500
HI 31 20
X1 32 4 0 500 1000 1000 1000
GR 50 0 0 50 0 450 50 500
HI 32 20
X1 33 4 0 500 1000 1000 1000
GR 50 0 0 50 0 450 50 500
HI 33
X1 34 4 0 500 1000 1000 1000
GR 50 0 20 50 20 450 50 500
HI 34 20 .01 200 300 3

```

X1	35	4	0	500	1000	1000	1000		
GR	50	0	0	50	0	450	50	500	
HI	35	20							
X1	36	4	0	500	1000	1000	1000		
GR	50	0	0	50	0	450	50	500	
HI	36	20							
EJ									
\$SEGS	3	4	4						
T1+	EX NO. 26. TEST TWO LOOPS. SEGMENT 4 = U/S FROM 1ST LOOP								
T2	HEC-6T VERSION 4.00. 1 MAY 1994, WA THOMAS								
T3									
NC	.150	.150	.025	.3	.1				
X1	40	4	0	500	0	0	0		
GR	50	0	0	50	0	450	50	500	
HI	40	20				-5	200	300	4
PX		1				4	.000		1000
EJ									
\$SEGS	4	5	5						
T1+	EX NO. 26. TEST LOOP 2 CALCULATION. SEGMENT 5 = AROUND ISLAND								
T2	HEC-6T VERSION 4.00. 7 APR 1995, WA THOMAS								
T3									
NC	.150	.150	.025	.3	.1				
X1	50	4	0	500	0	0	0		
GR	50	0	0	50	0	450	50	500	
HI	50	20				-5	200	300	5
PX		1				4	.000		2000
EJ									
\$SEGS	4	5	6						
T1+	EX NO. 26. TEST LOOP 2 CALCULATION. SEGMENT 6 = DRY SIDE OF IS								
T2	HEC-6T VERSION 4.00. 1 MAY 1994, WA THOMAS								
T3									
NC	.150	.150	.025	.3	.1				
NV	11	.150							
NV	23	.025	0	.050	10	.150	50		
NV	33	.020	0	.025	5	.020	10		
NV	43	.025	0	.050	10	.150	50		
NV	51	.150							
X1	61	4	0	499	0	0	0		
XB	1	50	450	499	500				
GR	50	0	0	50	0	450	50	500	
HI	61	20							
X1	62	4	0	500	1000	1000	1000		
XB	1	50	450	499	500				
GR	50	0	0	50	0	450	50	500	
HI	62	20							
X1	63	4	0	500	1000	1000	1000		
XB	1	50	450	499	500				
GR	50	0	9	50	9	450	50	500	
HI	63	20				.01	200	300	6
X1	64	4	0	500	1000	1000	1000		
XB	1	50	450	499	500				
GR	50	0	9	50	9	450	50	500	
HI	64	20				.01	200	300	6
X1	65	4	0	500	1000	1000	1000		
XB	1	50	450	499	500				
GR	50	0	9	50	9	450	50	500	
HI	65	20				.01	200	300	6
X1	66	4	0	500	1000	1000	1000		
XB	1	50	450	499	500				
GR	50	0	0	50	0	450	50	500	
HI	66	20							
EJ									

```

$SEG 5 6 7
T1+ EX NO. 26. TEST TWO LOOPS. SEGMENT 7 = APPROACH CH U/S FROM ISLANDS
T2 HEC-6T VERSION 4.00. 1 MAY 1994, WA THOMAS
T3
NC .150 .150 .025 .3 .1
X1 70 4 0 500 0 0 0
GR 50 0 0 50 0 450 50 500
HI 70 20 1 200 300 7
2
PX 1 4 .000 1000
EJ
T4 EX. NO. 26 SEDIMENT DATA FOR 2-LOOPS, WET/DRY. D/S SEGMENT = 1/7
T5 BED GRADATION ARE HYPOTHETICAL
T6 SEDIMENT INFLOW IS HYPOTHETICAL
T7
T8
I1 10
I4 14 1 2
PF 1.0 8.0 .50 96.0 .0625 0
$SEG 2 3 2
T4+ EX. NO. 26 SEDIMENT DATA FOR ISLAND FLOW TEST. IS.1 SEGMENT = 2/7
T5
T6
T7
T8
PF 1.0 8.0 .50 96.0 .0625 0
$SEG 2 3 3
T4+ EX. NO. 26 SEDIMENT DATA FOR ISLAND FLOW TEST. IS.1 SEGMENT = 3/7
T5
T6
T7
T8
PF 1.0 8.0 .50 96.0 .0625 0
$SEG 3 4 4
T4 EX. NO. 26 SEDIMENT DATA FOR ISLAND FLOW TEST. U/S IS1 SEGMENT = 4/7
T5 BED GRADATION ARE HYPOTHETICAL
T6 SEDIMENT INFLOW IS HYPOTHETICAL
T7
T8
I1 10
I4 14 1 2
PF 1.0 8.0 .50 96.0 .0625 0
$SEG 4 5 5
T4+ EX. NO 8 SEDIMENT DATA FOR ISLAND FLOW TEST. IS.2 SEGMENT = 5/7
T5
T6
T7
T8
PF 1.0 8.0 .50 96.0 .0625 0
$SEG 4 5 6
T4+ EX. NO. 26 SEDIMENT DATA FOR ISLAND FLOW TEST. IS.2 SEGMENT = 6/7
T5
T6
T7
T8
PF 1.0 8.0 .50 96.0 .0625 0
$SEG 4 5 7
T4+ EX. NO. 26 SEDIMENT DATA FOR ISLAND FLOW TEST. U/S IS.2 SEGMENT =
7/7
T5
T6
T7

```

```

T8
CP      6
LQ      1  50000
LC      100  2000
LF      .8  .8
LF      .2  .2
PF      1.0  8.0  .50  96.0  .0625  0
$HYD
$CL     2
$CL     5
$OQC
OC      2  2  50
OC      4  5  50
*  AB  RUN 1
Q  10000
R      10
T      45  45
W      1
$DREDGE
DC      1  1  1000
DC      2  2  5000
DC      3  2  100000
DC      4  1  100
DC      5  2  1000
DC      6  2  5000
DC      7  2  10000
*  B  RUN 2
Q  10000
W      1
*  B  RUN 3
Q  10000
W      1
*  B  RUN 4
Q  10000
W      1
*  B  RUN 5
Q  10000
W      1
$$END

```

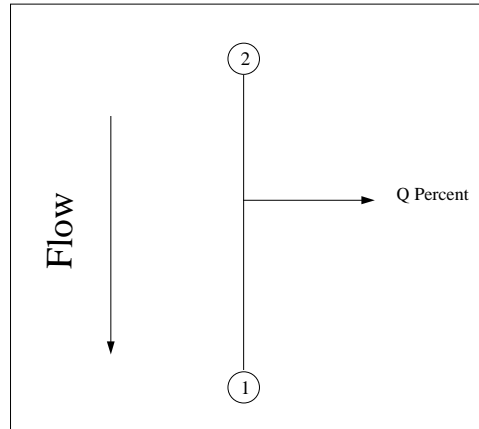

Figure C-10.

EXAMPLE NO. 29. TEST LOCAL OUTFLOW OPTION USING QP-RECORDS

```

T1      EXAMPLE NO. 29.  TEST LOCAL OUTFLOW OPTION USING QP-RECORDS
T2      HEC-6T  VERSION 4.00.    4 MARCH 1996,    WA THOMAS
T3
NC              .3      .1
NV    11      .150
NV    21      .025
NV    31      .150
X1    800      25 3373.49 3631.46      0      0      0
X3     10
GR5577.6 3100.23 5578.9 3113.0 5578.1 3291.29 5578.6 3322.26 5578.26
3350.49
GR5578.6 3373.49 5571.4 3393.49 5570.06 3400.49 5569.2 3410.49 5568.6
3430.49
GR5568.6 3450.49 5569.2 3490.49 5569.5 3500.49 5569.4 3510.49 5569.8
3530.49
GR5570.8 3540.49 5572.0 3560.49 5572.5 3569.49 5574.9 3580.49 5575.3
3590.49
GR5576.3 3600.49 5577.3 3627.49 5577.2 3631.46 5576.5 3681.22 5576.5
3681.32
H      800
X1    1160      25 3073.53 3308.53      360      360      360
X3     10
GR5575.5 3063.53 5576.4 3068.53 5578.08 3073.53 5569.6 3113.53 5569.1
3123.53
GR5569.2 3133.53 5568.9 3143.53 5569.1 3153.53 5570.9 3183.53 5571.5
3203.53
GR5571.8 3233.53 5572.3 3243.53 5572.3 3248.53 5572.1 3253.53 5571.5
3258.53
GR5570.8 3263.53 5571.7 3273.53 5572.2 3277.53 5572.5 3278.53 5575.18
3290.53
GR5576.6 3296.53 5577.2 3308.53 5576.8 3321.53 5576.9 3385.93 5576.9
3441.4
H      1160
X1    1660      10 2582.34 3020.34      500      500      500
X3     10
GR5577.5 2286.19 5578.5 2582.34 5577.78 2585.34 5577.8 2592.34 5577.62
2602.34
GR5580.7 3018.34 5580.8 3020.34 5578.3 3029.08 5580.6 3042.35 5580.5
3055.69

```

H	1660								
QP	-10	0	-50	2000					
X1	1960	15	2857.84	3291.27	300	300	300		
X3	10								
GR5582.0	2750.39	5579.1	2768.72	5579.1	2771.91	5578.9	2847.84	5578.9	
2857.84									
GR5578.3	3262.84	5580.8	3271.84	5581.29	3276.84	5581.8	3291.27	5581.7	
3308.30									
GR5582.2	3329.02	5586.1	3355.42	5586.6	3371.5	5582.2	3392.08	5581.8	
3398.70									
H	1960								
X1	2220	10	2745.72	3053.72	260	260	260		
X3	10								
GR5575.9	2698.72	5577.0	2702.72	5577.9	2722.72	5577.1	2732.72	5577.09	
2745.72									
GR5569.1	3012.72	5568.8	3022.72	5579.2	3053.72	5587.0	3175.03	5586.8	
3184.7									
H	2220								
NC			.025						
EJ									
T4									
T5									
T6									
T7									
T8									
I1		10							
I4		14	1	11					
LQ	Q	10	30000.						
LTLTOTAL									
LF	VFS								
LF	FS								
LF	MS								
LF	CS								
LF	VCS								
LF	VFG								
LF	FG								
LF	MG								
LF	CG								
LF	VCG								
LF	SC								
PF		800	1.0	128.0	64.0	36.0	32.0	31.0	16.0
28.0									
PFC	8.0	27.0	4.0	25.0	2.0	24.0	1.0	19.0	.50
16.0									
PFC	.250	15.0	.125	13.0					
\$LOCAL									
LQL		-5000	-1	1	5000				
LCLTOTAL				100	100				
LFL	VFS	1	1	.3	.3				
LFL	FS	.1	.1	.2	.2				
LFL	MS	0	0	.1	.1				
LFL	CS	0	0	.05	.05				
LFL	VCS			.05	.05				
LFL	VFG			.05	.05				
LFL	FG			.05	.05				
LFL	MG			.05	.05				
LFL	CG			.05	.05				
LFL	VCG			.05	.05				
LFL	SC			.05	.05				
\$HYD									
*	AB	RUN	1						
Q	2000	500							

R 5578  
T 45 50  
W .1  
\$\$END

## **APPENDIX D**

### **EXAMPLE PRINTOUT**



## Appendix D

# EXAMPLE PRINTOUT

### Banner

The first page of printout shows the program Version Number, date and Array Sizes, Figure D-1.

### Geometric Data Printout

The geometric printout begins with the **TABLE GEO-1 GEOMETRIC MODEL** followed by the Title Records. The segment number comes next and one line of n-values follows that n-value line, Figure D-1.

The program has read all geometric data at the **END OF GEOMETRIC DATA** printout. Printout is written as each data record is processed. Therefore, when an error occurs one can go to the end of the printout file to see what portion of the input data file was being read and begin the search for the cause of the error.

### Sediment Data Printout

Reading the sedimentary data begins with **TABLE SED-1. SEDIMENTARY DATA**. The T4 - T8-Records are read first, Figure D-1. The "I1 and I4" labels refer to record types. They are explained in the appendix, "Description of Sedimentary Data." As in the case of the Geometric Data, printout is made as each record is processed to aid in debugging when an error occurs.

The following tables refer to Figure D-1.

Table SED-2 summaries the particle size classes assembled from the I2 - I4-Record types.

Table SED-3 summarizes the inflowing sediment load from LQ-LT-LF-Records.

Table SED-4 are primarily to show the initial elevation of the bed sediment reservoir and the location of cross sections by accumulated distance from the downstream end -- a column often desirable for plotting profiles.

Table SED-5 is the gradation of the **BED SEDIMENT RESERVOIR** read from PF-Records.

Table SED-8 shows dimensions of the bed sediment reservoir by reach. In each case the cross section shown in the first column is the central cross section in the reach.

A note is printed at the **END OF SEDIMENT DATA**. At this point all Sedimentary Data have been read, and the program has reached the \$HYD-Record signifying the start of the Hydrological Data Set.



## Hydrologic Data Printout

The last record read in the Sedimentary Data Subroutine is the \$HYD-Record. It causes the program to print "**BEGIN COMPUTATIONS**". Next the program switches to the Hydraulic Calculations, beginning in SUBROUTINE BWMOD4, and reads the first record, in the HYDROLOGIC DATA SET, after the \$HYD. Most Command Records are read from this subroutine. Therefore, if an abort occurs in Subroutine BWMOD4, it is most likely a Command Record.

The Subroutine which actually reads the Hydrologic Data Set is BCMOD3. Input errors from this Subroutine will usually come from Record Types Q, R, S, T, W and X. These are called the **EVENT Records**. In addition to the EVENT Records, two Commands, \$OQC and \$WSCP, are read from this subroutine.

After the program reads the Water Discharge Record (Q), it calculates the Water discharge at each Junction Control Point. Then it assigns the outflows from each junction to each cross section on each segment. After reading the Water Temperature, the program makes a similar assignment of the Water Temperatures and prints out a Table with the following title:

"TABLE HYD-1. NETWORK WATER DISCHARGES AND TEMPERATURES."

That table is shown in Figure D-1..

## Hydraulic Calculations

No hydraulic results will be printed unless printout is requested on the \* **Record**. (SEE Description of Hydrologic Data) The two levels which can be requested are the A-Level and the B-Level printout which are described in Table D-1. A sample A-Level printout is annotated in Figures D-2 and D-3.

A printout request lasts for only one event. The following \* Record illustrates a request for A-LEVEL Printout in Hydraulic Calculations. (NOTE: The "B" is printout for Sedimentation Calculations. It will be described later under Sedimentation Calculations.)

"\* **AB RUN 1**" Record.

After reading all records in an event, i.e. \*-Q R-T-W or X, the program will begin Water Surface profile calculations. Just prior, it will print

**EVENT 1 WSP# 1 RUN 1,**

followed by the three Title-Records which were read in the Geometric Model for this segment. That will allow the calculated results in the Hydraulic, Sedimentation and Bed Change printout to be matched with the proper geometry and sedimentary data sets.

It will print out the Boundary Conditions, Column headings and the HA- table as follows:

**TABLE HA- i CROSS SECTION ID. xxxxxxxx.xxx.**

The water surface elevation is then calculated for that cross section and the results are printed out. This technique is another case where printout can aid in locating computational errors by always being current with the calculations.

## Sedimentation Calculations

Table Identifiers for Sedimentation output are SA- , SB- and SC- for Sedimentation; A-Level and Sedimentation; B-Level. These headings aid searching output with editors.

There is one SA- table, two SB- tables and one SC- table as shown in Figure D-1. The purpose of the SA-1 table is to give the accumulated inflow into the model and the accumulated outflow of sediment from the model along with the calculated trapping efficiency. When local inflows/outflows are present in the model, the values are included in the SA-1 Table. The units are volumetric --- acre-feet.

The SB-1 table gives the inflowing sediment load from the Sediment Inflow Boundary Condition Table, i.e. TABLE SED-3 Q-QS RATING TABLE. These values are rates in tons/day for the inflowing water discharge in this EVENT. A value is present for each particle size.

The SB-1 table also gives the calculated sediment load flowing out of the downstream end of the model.

The SB-2 table is the most widely used printout from the model. It shows an estimate of the Bed Change, the calculated Water Surface Profile at the beginning of the Event, The calculated thalweg elevation at the time shown in the Title of this SB-2 table, the Total Water Discharge at each cross section, and the sediment discharge passing each cross section. The sediment discharge is under a general column heading: SEDIMENT LOAD IN TONS/DAY. Figure D-1 shows only SAND under that general heading. That is because there are no clay or silt discharges in this model. If CLAY and SILT were present, each would be shown in a column along with SAND. Note also that there are GRAVEL and COBBLES in this sediment load table, TABLE SED-3. There will not be Gravel and Cobble headings because of page width. These are lumped into the SAND column because they are all non-cohesive particles and are assumed to obey the same laws of transportation.

The SC-1 table gives the accumulated water discharge from each Segment in Acre-Feet.

Below the SC- table is a calculation of the residence time a particle of water spends in each Segment of the model.

After the Sedimentation Tables there are two tables which are produced with the \$VOL command. The first is

### **TABLE VOL-1. SEDIMENT DELIVERY AND BED ACCUMULATION AFTER 0.100000 DAYS.**

This table displays the accumulated sediment entering the upstream boundary of the model and the calculated amount delivered to the downstream end of the model during the entire calculation hydrograph. It shows those values by cross section. In a steady state sedimentation problem, the accumulated INFLOW would equal the accumulated mass passing each cross section and finally passing out of the model. The SEDIMENT DEPOSITING columns are calculated from the SEDIMENT PASSING values. Note that units are different. Sediment passing values are expressed in their usual units of tons. Deposits are converted to volumetric units which, in this case, are cubic yards. This is a very useful table for verification as well as model predictions.

The final table in Figure D-1 is

### **TABLE VOL-2. ACCUMULATED WEIGHT BY SIZE CLASS.**

This table shows the accumulated weight in each size class which is delivered past each cross section in the model. Note, this is weight in tons and not rate in tons/day.



**Figure D-1. Example Printout**

```

10:05:15.85      05/16/95
*****
*          ...SEDIMENTATION IN STREAM NETWORKS...          *
*                      BY                      *
*                      William A. Thomas          *
*                      *                      *
*                      *                      *
*                      *                      *
* VERSION 4.00                      JUNE 15, 1994 *
*   MOD .30                      MAY 13, 1995  *
*                      *                      *
* MOBILE BOUNDARY HYDRAULICS      William A. Thomas, Owner *
* 425 RIDGEWOOD DRIVE            TELEPHONE 601-634-9543 *
* VICKSBURG, MISSISSIPPI 39180    FAX 601-634-9543  *
*                      *                      *
*                      *                      *
* COPYRIGHT PENDING,  ALL RIGHTS RESERVED.          *
*****

```

```

*****
* Disclaimer: *
* This computer program was written for use by engineers *
* and scientist who are competent in the field of Sedimen- *
* tation Engineering. It provides a framework for perform- *
* ing Sedimentation Studies. *
* *
* This Program and Documentation are provided "AS IS," with- *
* out warranty of any kind, either express or implied. All *
* warranties of any type respecting this program and/or the *
* documentation are hereby disclaimed by the author. *
* *
*                      William A. Thomas *
*****

```

```

THIS PROGRAM IS DIMENSIONED FOR:
MAXIMUM NUMBER OF CROSS SECTIONS           = 250
MAXIMUM NUMBER OF CONTROL POINTS           = 20
MAXIMUM NUMBER OF SEGMENTS                 = 25
MAXIMUM NUMBER OF SEGMENTS JOINING A CONTROL POINT= 3
MAXIMUM NUMBER OF LOCAL INFLOW POINTS PER SEGMENT = 10
MAXIMUM NUMBER OF CROSS SECTION (STA,ELEV) POINTS = 100
MAXIMUM NUMBER OF GRAIN SIZES              = 20

```

```

TABLE GEO-1. GEOMETRIC MODEL.
T1      EXAMPLE NO. 1. SIMPLE TEST USING P-RECORD MODEL EXTENSION. NO LOCALS
T2      MBH-1 VERSION 4.00. 4 MARCH 1994, WA THOMAS
T3

```

```

SEGMENT NUMBER = 1
NC0.1500 0.1500 0.0250 0.3000 0.1000

```

```

SECTION NO. 1 RIVER MILE= 800.000

```

```

INEFFECTIVE FLOW AREA REQUESTED BY X3-CARD. LEFT OVERBANK RIGHT OVERBANK
                STA #                2                5
                INEFFECTIVE ELEVATION 5599.980        5599.987

```

```

SECTION NO. 2 RIVER MILE= 1160.000

```

```

INEFFECTIVE FLOW AREA REQUESTED BY X3-CARD. LEFT OVERBANK RIGHT OVERBANK
                STA #                2                5
                INEFFECTIVE ELEVATION 5599.930        5599.993

```

```

SECTION NO. 3 RIVER MILE= 1660.000

```



TABLE SED-1. SEDIMENTARY DATA

T4 EX. NO. 1 SEDIMENT DATA FOR SIMPLE MODEL TEST USING P-RECORD EXTENSION  
 T5 BED GRADATION ARE HYPOTHETICAL  
 T6 SEDIMENT INFLOW IS HYPOTHETICAL  
 T7  
 T8

SEDIMENT PARAMETER DATA

I1	SPI	IBG	MNQ	SPGF	ACGR	NFALL	IBSHER
	10.	0	1	1.000	32.174	2	1

SAND (AND LARGER) SIZES ARE PRESENT

I4	MTC	IASA	LASA	SPGS	GSF	BSAE	PSI	UWDLB
	14	1	11	2.650	0.667	0.500	30.000	93.000

TABLE SED-2. FOLLOWING GRAIN SIZES UTILIZED

CLASS	INTERVAL	MEDIAN	SHAPE	SP WT	COVER	SP WT	CLASS	Y/D
---	-----	-----	DIA	FAC.	INACTIVE	LAYER	ACTIVE	#
:	:	:	:	:	LAYER	COEF.	LAYER	:
#	(MM)	(FT)	(FT)	:	TON/CF	SQFT/TON	TON/CF	:
	0.0625	0.000205						
1	SAND SIZE=	0.000290	0.7	0.0465	37079.8		0.0465	3
	0.1250	0.000410						
2	SAND SIZE=	0.000580	0.7	0.0465	18539.9		0.0465	3
	0.2500	0.000820						
3	SAND SIZE=	0.001160	0.7	0.0465	9269.94		0.0465	3
	0.5000	0.001640						
4	SAND SIZE=	0.002320	0.7	0.0465	4634.97		0.0465	3
	1.0000	0.003281						
5	SAND SIZE=	0.004640	0.7	0.0465	2317.49		0.0465	3
	2.0000	0.006562						
6	GRAVEL =	0.009280	0.7	0.0465	1158.74		0.0465	3
	4.	0.013123						
7	GRAVEL =	0.018559	0.7	0.0465	579.371		0.0465	3
	8.	0.026247						
8	GRAVEL =	0.037118	0.7	0.0465	289.686		0.0465	3
	16.	0.052493						
9	GRAVEL =	0.074237	0.7	0.0465	144.843		0.0465	3
	32.	0.104987						
10	GRAVEL =	0.148474	0.7	0.0465	72.4214		0.0465	3
	64.	0.209974						
11	COBB/BOUL=	0.296948	0.7	0.0465	36.2107		0.0465	3
	128.	0.419948						

TRANSPORT FUNCTION IS -- COPELAND LAURSEN MTC = 14

TABLE SED-3. Q-QS RATING TABLE

THIS SEDIMENT DISCHARGE TABLE IS FOR SEGMENT NUMBER 1  
 AT CONTROL POINT NO. 2  
 LOAD BY GRAIN SIZE CLASS, TONS/DAY

LQ	Q* 10.0000	* 30000.0	*
LF	VFS*0.100000E-19	*0.100000E-19	*
LF	FS*0.100000E-19	*0.100000E-19	*
LF	MS*0.100000E-19	*0.100000E-19	*
LF	CS*0.100000E-19	*0.100000E-19	*
LF	VCS*0.100000E-19	*0.100000E-19	*
LF	VFG*0.100000E-19	*0.100000E-19	*
LF	FG*0.100000E-19	*0.100000E-19	*
LF	MG*0.100000E-19	*0.100000E-19	*
LF	CG*0.100000E-19	*0.100000E-19	*
LF	VCG*0.100000E-19	*0.100000E-19	*
LF	SC*0.100000E-19	*0.100000E-19	*
	-----	-----	
	SUM=*0.110000E-18	*0.110000E-18	*

TABLE SED-4. CROSS SECTION LOCATIONS

SEC NO.	REACH	INITIAL BED ELEVATIONS	ACCUMULATED CHANNEL DISTANCE
---------	-------	------------------------	------------------------------

	LENGTH LEFT SIDE	THALWEG	RIGHT SIDE	FRP, DOWNSTREAM FEET	MILES
	0.00				
800.000	3600.00	5600.00	5560.00	5600.00	0.0
1160.000	5000.00	5600.00	5565.00	5600.00	3600.0
1660.000	1000.00	5600.00	5568.00	5575.00	8600.0
1661.000	1000.00	5601.00	5569.00	5576.00	9600.0
1662.000	1000.00	5602.00	5570.00	5577.00	10600.0
1663.000	1000.00	5603.00	5571.00	5578.00	11600.0

TABLE SED-5. GRADATION OF BED SEDIMENT RESERVOIR FROM PF-RECORDS.

ASN	SAE	DMAX	DXPI	XPI	PI ( )	PI ( )	PI ( )	PI ( )	PI ( )
N	1.0000	0.4199	0.4199	0.0000	0.0064	0.0200	0.0100	0.0300	0.0300
					0.0500	0.0100	0.0200	0.0100	0.0300
					0.0500	0.6400			
N	1.0000	0.4199	0.4199	0.0000	0.0064	0.0200	0.0100	0.0300	0.0300
					0.0500	0.0100	0.0200	0.0100	0.0300
					0.0500	0.6400			
N	1.0000	0.4199	0.4199	0.0000	0.0064	0.0200	0.0100	0.0300	0.0300
					0.0500	0.0100	0.0200	0.0100	0.0300
					0.0500	0.6400			
N	1.0000	0.4199	0.4199	0.0000	0.0064	0.0200	0.0100	0.0300	0.0300
					0.0500	0.0100	0.0200	0.0100	0.0300
					0.0500	0.6400			

ACTIVE DEPOSITS, WT. IN TONS

NONE SPECIFIED, ASSUMED ZERO

THIS STREAM NETWORK HAS \*\*\*, 1 \*\*\* SEGMENTS.  
 AND \*\*\*, 2 CONTROL POINTS.

TABLE SED-8. DIMENSIONS OF BED SEDIMENT CONTROL VOLUMES, FEET.

SEGMENT #:	1EXAMPLE NO. 1.	SIMPLE TEST USING P-RECORD MODEL EXTENSION.	NO LOCALS
SEC. NO. *	LENGTH	* MAX. WIDTH *	* DEPTH
* V O L U M E *			
* CU. FT. * CU. YD. *			
800	* 1800.00	* 58.0000	* 10.0000
1160	* 4300.00	* 68.8837	* 10.0000
1660	* 3000.00	* 94.6667	* 10.0000
1661	* 1000.00	* 108.0000	* 10.0000
1662	* 1000.00	* 108.0000	* 10.0000
1663	* 500.000	* 108.0000	* 10.0000
			* 0.104400E+07* 38666.7 *
			* 0.296200E+07* 109704. *
			* 0.284000E+07* 105185. *
			* 0.108000E+07* 40000.0 *
			* 0.108000E+07* 40000.0 *
			* 540000. * 20000.0 *

NO. OF INPUT DATA MESSAGES= 1

END OF SEDIMENT DATA

1

\$HYD

\* AB RUN 1

TABLE HYD-1. NETWORK WATER DISCHARGES AND TEMPERATURES.

SEGMENT NO	CROSS SECTION NO	NXSA	CROSS SECTION	WATER DISCHARGE	WATER TEMPERATURE
AMPLE NO. 1.	SIMPLE TEST USING P-RECORD MODEL EXTENSION.	NO LOCALS			
1	1	1	800.000	2000.000	45.000
1	2	2	1160.000	2000.000	45.000
1	3	3	1660.000	2000.000	45.000
1	4	4	1661.000	2000.000	45.000
1	5	5	1662.000	2000.000	45.000
1	6	6	1663.000	2000.000	45.000

BEGIN HYDRAULIC CALCULATIONS.

EVENT 1 WSP# 1 RUN 1  
T1 EXAMPLE NO. 1. SIMPLE TEST USING P-RECORD MODEL EXTENSION. NO LOCALS  
T2 MBH-1 VERSION 4.00. 4 MARCH 1994, WA THOMAS  
T3

BOUNDARY CONDITION DATA, SEGMENT NO. 1 CP NO. 1  
WATER DISCHARGE= 2000.00  
ELEVATION= 5578.000  
TEMPERATURE= 45.000  
FLOW DURATION (DAYS) 0.1000

****	DISCHARGE CFS	WATER SURFACE	ENERGY LINE	VELOCITY HEAD	ALPHA	TOP WIDTH	AVG BED ELEV
TABLE HA-	1.	CROSS SECTION ID.		800.000			
**** Q	2000.0	5578.000	5578.576	0.576	1.000	29.50	5566.86
*** FLOW	VELOCITY,	FPS =	0.00	6.09	0.00		
*** FLOW	DISTRIBUTION (%) =		0.00	100.00	0.00		
TABLE HA-	2.	CROSS SECTION ID.		1160.000			
**** Q	2000.0	5581.495	5582.196	0.701	1.000	31.00	5571.89
*** FLOW	VELOCITY,	FPS =	0.00	6.72	0.00		
*** FLOW	DISTRIBUTION (%) =		0.00	100.00	0.00		
TABLE HA-	3.	CROSS SECTION ID.		1660.000			
**** Q	2000.0	5584.839	5584.960	0.121	5.967	106.10	5568.03
*** FLOW	VELOCITY,	FPS =	0.16	5.94	0.96		
*** FLOW	DISTRIBUTION (%) =		0.14	19.97	79.90		
TABLE HA-	4.	CROSS SECTION ID.		1661.000			
**** Q	2000.0	5585.078	5585.210	0.132	5.967	106.01	5569.00
*** FLOW	VELOCITY,	FPS =	0.16	6.21	1.00		
*** FLOW	DISTRIBUTION (%) =		0.13	19.98	79.89		
TABLE HA-	5.	CROSS SECTION ID.		1662.000			
**** Q	2000.0	5585.357	5585.503	0.146	5.968	105.92	5570.03
*** FLOW	VELOCITY,	FPS =	0.17	6.52	1.05		
*** FLOW	DISTRIBUTION (%) =		0.13	19.99	79.88		
TABLE HA-	6.	CROSS SECTION ID.		1663.000			
**** Q	2000.0	5585.686	5585.846	0.160	5.968	105.83	5571.04
*** FLOW	VELOCITY,	FPS =	0.18	6.83	1.10		
*** FLOW	DISTRIBUTION (%) =		0.12	20.00	79.88		

TABLE SA-1. EXAMPLE NO. 1. SIMPLE TEST USING P-RECORD MODEL EXTENSION. NO LOCALS  
 ACCUMULATED AC-FT ENTERING AND LEAVING SEGMENT # 1

```
*****
TIME          ENTRY *          SAND          *
DAYS         POINT *        INFLOW    OUTFLOW  TRAP EFF*
0.10        1663.000*        0.00      0.00    0.00
TOTAL=      800.000*        0.00      0.33*****
*****
```

TABLE SB-1. TOTAL: LOAD BY SIZE CLASS IN TONS/DAY  
 FINEST TO COARSEST PARTICLE SIZES

```
SEDIMENT INFLOW: CP= 2
SAND AND/OR GRAVEL=      0.      0.0      0.0      0.0      0.0      0.0
                          0.0      0.0      0.0      0.0      0.0
                          0.0
SEDIMENT OUTFLOW: CP= 1
SAND AND/OR GRAVEL=     6586.    1243.2    3296.5    829.3    639.4    396.9
                          50.6      72.0     23.7     34.5     0.1
                          0.0
```

TABLE SB-2: SEGMENT 1 STATUS OF THE BED PROFILE AT TIME = 0.100 DAYS

```
-----
SECTION      BED      WS ELEV  THALWEG      Q      SEDIMENT LOAD IN TONS/DAY
ID NO      CHANGE  FEET      FEET      CFS      SAND
1663.00    -0.02  5585.69  5570.98     2000.    560.
1662.00     0.00  5585.36  5570.00     2000.    698.
1661.00     0.00  5585.08  5569.00     2000.    697.
1660.00     0.00  5584.84  5568.00     2000.   1145.
1160.00    -0.06  5581.49  5564.94     2000.   6290.
 800.00    -0.01  5578.00  5559.99     2000.   6586.
```

TABLE SC-1. NETWORK SEGMENT NO 1  
 EXAMPLE NO. 1. SIMPLE TEST USING P-RECORD MODEL EXTENSION. NO LOCALS  
 ACCUMULATED WATER DISCHARGE FROM DAY ZERO (ACRE FEET)

```
OUTFLOW      LOCAL #1    LOCAL #2    LOCAL #3    LOCAL #4    LOCAL #5
396.694
```

EVENT DURATION(DAYS) = 0.1000  
 RESIDENT TIME BY SEGMENT.

```
SEGMENT
NUMBER  TIME(DAYS)
1       0.2116E-01
```

\$VOL A

SEGMENT # 1: EXAMPLE NO. 1. SIMPLE TEST USING P-RECORD MODEL EXTENSION. NO LOCALS

TABLE VOL-1. SEDIMENT DELIVERY AND BED ACCUMULATION AFTER 0.100000 DAYS.

SECTION	SEDIMENT PASSING SECTION IN TONS				:	SEDIMENT DEPOSITED IN REACH IN CUBIC YARDS			
	TOTAL	SAND	SILT	CLAY	TOTAL	ACCUMULATED	SAND	SILT	CLAY
INFLOW	0.	0.	0.	0.	0.				
1663.000	56.	56.	0.	0.	-45.	-45.	-45.	0.	0.
1662.000	70.	70.	0.	0.	-11.	-56.	-11.	0.	0.
1661.000	70.	70.	0.	0.	0.	-56.	0.	0.	0.
1660.000	115.	115.	0.	0.	-36.	-91.	-36.	0.	0.
1160.000	629.	629.	0.	0.	-410.	-501.	-410.	0.	0.
800.000	659.	659.	0.	0.	-24.	-525.	-24.	0.	0.

TABLE VOL-2. ACCUMULATED WEIGHT BY SIZE CLASS.

: VF : F : M : C : VC :

INFLOW

SAND :.100000E-20:.100000E-20:.100000E-20:.100000E-20:.100000E-20:  
 GRAV :.100000E-20:.100000E-20:.100000E-20:.100000E-20:.100000E-20:  
 C/BO :.100000E-20:

RIVER MILE = 1663.000

SAND :10.5735 :32.9461 :4.79286 :3.86988 :2.77974 :  
 GRAV :.383646 :.513383 :.139484 :.498377E-02:.100000E-20:  
 C/BO :.100000E-20:

RIVER MILE = 1662.000

SAND :18.9859 :39.2402 :4.58638 :3.50883 :2.52040 :  
 GRAV :.346190 :.459899 :.122479 :.324380E-02:.100000E-20:  
 C/BO :.100000E-20:

RIVER MILE = 1661.000

SAND :24.3529 :36.3479 :3.58787 :2.68969 :2.00759 :  
 GRAV :.273236 :.355032 :.873538E-01:.777503E-03:.100000E-20:  
 C/BO :.100000E-20:

RIVER MILE = 1660.000

SAND :37.4217 :58.8801 :7.21737 :5.72893 :3.67184 :  
 GRAV :.514906 :.717426 :.221314 :.175429 :.770023E-04:  
 C/BO :.100000E-20:

RIVER MILE = 1160.000

SAND :109.224 :282.609 :86.5200 :76.8501 :50.3610 :  
 GRAV :6.41490 :9.22608 :3.08440 :4.65813 :.274505E-01:  
 C/BO :.100000E-20:

RIVER MILE = 800.000

SAND :124.322 :329.655 :82.9255 :63.9378 :39.6868 :  
 GRAV :5.05567 :7.19840 :2.37247 :3.44886 :.136788E-01:  
 C/BO :.100000E-20:

0 FATAL DATA ERRORS DETECTED.  
 1 INFORMATION MESSAGES DETECTED.

TOTAL NO. OF EVENTS READ= 1  
 TOTAL NO. OF WS PROFILES= 1  
 ITERATIONS IN EXNER EQ = 60

END OF JOB  
 10:05:16.35 05/16/95

## Annotated A-Level printout from Hydraulic Calculations

The A-Level printout from Hydraulic Calculations produces the output shown in Figure D-2. A Table containing 3 lines is printed for each cross section. It begins with four astricks which matches the output values to column headings, also denoted by four astricks. For example, 5578.576 on the \*\*\*\* Q line matches the column heading, **Energy Line**. The Cross Section identification is 800. The sequence number for this cross section is 1. Sequence number is relative to the Segment. Therefore, this is the first cross section on this segment.

Sub-tables for each cross section are marked with three astricks. The \*\*\* **FLOW VELOCITY** line, for example, is a sub-table for Cross Section 800.000 It shows three values. These are for the Left Overbank, Main Channel, and Right Overbank strips, respectively. The terms Left and Right expect the cross sections to be coded left to right facing downstream. In reverse flow, downstream is assumed to be toward the first cross section in the Geometric Data Set for the Segment.

**Table D-4.** Printout from Hydraulic Calculations

A-LEVEL	B-LEVEL
Water Discharge	same as A-LEVEL
Calculated Water Surface Elevation	"
Calculated Total Energy Elevation	"
Alpha Coefficient	"
Water surface width	"
Average Bed Elevation in Channel	"
Velocity in each Strip	"
Percentage of Total Flow in Each Strip	<b>plus:</b>
	Current Cross Section Co-ordinates
	Areas, Hydraulic Radii, n-values, reach lengths by strip at each end of reach
	Effective Velocity, Depth, Width, n-value, and Slope written into the hydraulic parameter arrays, at each cross section, for sedimentation calculations

Likewise, the flow distribution is printed as a sub-table for the Left Overbank, Main Channel, and Right Overbank. In this example all flow is in the channel strip.

****	DISCHARGE	WATER	ENERGY	VELOCITY	ALPHA	TOP	AVG BED
	CFS	SURFACE	LINE	HEAD		WIDTH	ELEV
TABLE HA-	1.	CROSS SECTION ID.		800.000			
**** Q	2000.0	5578.000	5578.576	0.576	1.000	29.50	5566.86
*** FLOW VELOCITY,	FPS =		0.00	6.09	0.00		
*** FLOW DISTRIBUTION(%)	=		0.00	100.00	0.00		

**Figure D-1. A-Level Printout for Normal Water Surface Profile Calculations**

If the program is calculating flow in distributaries or cutoff channels, it produces two tables for each cross section as shown in Figure D-3. The first table gives results from the base Q profile calculation, and the second table gives results from the Delta Q profile calculation.

****	DISCHARGE	WATER	ENERGY	VELOCITY	ALPHA	TOP	AVG BED
	CFS	SURFACE	LINE	HEAD		WIDTH	ELEV
TABLE HA-	4	CROSS SECTION ID.		23.000			
**** Q	10000.0	10.748	10.828	0.080	1.000	421.50	0.27
*** FLOW VELOCITY,	FPS =		0.00	2.27	0.00		
*** FLOW DISTRIBUTION(%)	=		0.00	100.00	0.00		
**** Q	11000.0	10.833	10.928	0.095	1.000	421.67	0.28
*** FLOW VELOCITY,	FPS =		0.00	2.47	0.00		
*** FLOW DISTRIBUTION(%)	=		0.00	100.00	0.00		

**Figure D-2. A-Level Printout from Water Surface Profile Calculations for Flow Distributions**

## **APPENDIX E**

### **INPUT DESCRIPTION FOR GEOMETRY DATA**



# INPUT DESCRIPTION FOR GEOMETRY DATA

## INTRODUCTION

An HEC-6T model is coded from downstream to upstream in direction. Segments must be coded in sequential order starting with segment 1. Code cross sections starting at the downstream end of the segment. Geometric data falls into two general types: cross section data and reach data. A reach refers to the space between two successive cross sections.

Cross Section data records are the X1, X3, X5, XL, XB, GR, H, HD, HE, HI and HL-Records. Reach data records are NC, ND, NK, NM, NV, QL, QP, QT, XC and XD-Records. It is usually desirable to group these record types by cross section and to separate the groups by blank lines so the data file is easy to read.

Reach length, which is obviously reach data, is coded on the X1-Record at the upstream cross section for the reach. Therefore, the first cross section in a segment may have a reach length, but that reach length is not used in the computations.

The n -values are reach values in HEC-6T. However, n - values are needed at the first cross section so place the n -value for the first reach before the first cross section for that segment.

The data records are presented in these appendices in the sequence in which the data should be coded into the data file. Some records are required and some are optional. These are marked as illustrated by the **E-1** record on the next page.

A comment record may be placed in the data file by leaving column 1 blank..

**\$SEG**

HEC-6 Input Description  
Geometry and Channel Properties

**\$SEG**

**E-1 \$SEG-Record - Segment Record (Required)**

The Segment record tells the program how to assemble the Network geometry, and it tells the program that this data set is coded in **VERSION 4 syntax**. Place one \$SEG-Record before each T1-T4 set on each segment of the network. To run historical data sets, do not include \$SEG-Records.

```

Example:           FIELDS
1234567 1234567 1234567 1234567 1234567 1234567 1234567 1234567
$SEG  1      2      1
T1      THE $SEG RECORD GOES PRIOR TO THE T1 - T3 RECORDS
T2
T3

```

Field	Variable	Value	Description
0		\$SEG	RECORD Identifier goes in Col 1-2
1	NCPD	+	The control point number at the downstream end of this branch
2	NCPU	+	The control point number at the upstream end of this branch
3	NGDS	+	Segment number

**E-2 Title Records (T1 - T3)<sup>1</sup>**

Three title records are required to precede the geometry data for each stream segment in the network. The program expects a T in Column 1. Additional printout of geometric data can be requested by specifying a B or C in Column 3 on the T1-Record.

Field	Variable	Value	Description
0	ICG,IDT	T1	Record identification in Columns 1 and 2. <b>T1, T2</b> and <b>T3</b> for the first, second and third title records, respectively.
Column 3 of T1-Record only		Blank (zero not allowed)	Normal printout lists data from title records and the <b>NC</b> -Record. Only the cross section identification number is listed for records <b>X1</b> through <b>EJ</b> .
	KSW(5)	B	This printout option prints the left and right bank assignments for the channel.
	KSW(5, 6, 10, 17)	C	This printout option activates a trace <sup>2</sup> printout through subroutine GMOD.
	KSW(4)	O	This option turns off all printout in the geometric data set except for cross section numbers-river miles.
2-10		Comments	Fields 2 through 10 (Columns 9-80) may be used for identification purposes such as labeling the data set, noting the date of the run, or other relevant information.

---

<sup>1</sup> Date Modified: December 13, 1994

<sup>2</sup> Use of this print option is not recommended. C-level trace printout is intended only for program debugging purposes.

# HEC-6 Input Description Geometry and Channel Properties

## E-3 Job Parameter Options

The two functions of the Job Parameter options are to over-ride the default 'tolerance' for trial and error convergence of the water surface profile calculations and/or, when it is desirable, to extend the model on a constant slope and cross section spacing. Two records are provided: the original P-Record and a modification of it, the PX-Record, which allows more control.

**P and PX-Records cannot be mixed on the same segment.**

### E-3.1 P-Record

Extend the model on a constant slope and cross section spacing using the final GR data set in the model as the template. Insert the P-Record after the T3-Record.

```
Example:          FIELDS
1234567 1234567 1234567 1234567 1234567 1234567 1234567 1234567 1234567 1234567
T1
T2
T3
P .002           4 .001 1000
```

Field	Variable	Value	Description
0		P	RECORD Identifier goes in Col 1-2
1	ALER	b,+	Allowable error between trial and computed water surface elevations.
2	ASEL	b,+	Not used; originally it was the average slope of the energy line and was used to make the first estimate for the water surface elevation.
3	CE	b,+	Coefficient of Expansion - see NC-RECORD
4	CC	b,+	Coefficient of Contraction - See NC-RECORD

HEC-6 Input Description  
Geometry and Channel Properties

**E-3.1 P-Record - (Continued)**

5	LFA		Option for alpha computation
		b	Calculates alpha using strips
		1	Sets alpha = 1.0
		2	Calculates alpha using every pair of cross section coordinates
6	NXSSG		Option to Extend the Model. ( <b>SEE PX-Record also.</b> )
		+	Total number of cross sections in the extended geometric model on current segment - not the number of cross sections to extend.
		b	Do not extend the model.
7	TAN	-,0,+	Slope of invert of extended model.
8	CRL	b,+	Distance between cross sections in extended model

**E-3.2 PX-Record - Cross Section Template<sup>3</sup>**

The PX-Record has the same purpose as the P-Record, but it differs in two respects. It offers additional options for extending the geometric model by using GR data sets as templates, but the length of the extension is counted differently as shown in field 6 (P -6). Place PX-Records after any cross section data set and that cross section will become the template for extending the model.

```

Example:          FIELDS
1234567 1234567 1234567 1234567 1234567 1234567 1234567 1234567 1234567 1234567
X1
GR
H
Px          .25              3      .001      500      1000      1500
    
```

Field	Variable	Value	Description
0		PX	RECORD Identifier goes in Col 1-2
1	ALER	b,+	Allowable error between trial and computed water surface or energy line elevations in convergence algorithms. (Same as P-Record)
2	DELASN	b,+	This value will be added to the XSECID (X1-1) value on the previous cross section to determine the (X1-1) value for each new cross section inserted by the program when extending a model.
		0,b	Calculated by converting the channel length of field 9 to miles.
		-,+	Enter the increment in what ever units are appropriate for the cross section identification values.
3	CE	b,+	Coefficient of Expansion - see NC-RECORD
4	CC	b,+	Coefficient of Contraction - See NC-RECORD

---

<sup>3</sup> Date Created: June 11, 1995

HEC-6 Input Description  
 Geometry and Channel Properties

**PX-Record - (Continued)**

Field	Variable	Value	Description
5	LFA		Option for alpha computation
		b	Calculates alpha using strips
		1	Sets alpha = 1.0
		2	Calculates alpha using every pair of cross section coordinates
6	NXTND	+	Number of cross sections to extend the geometric model.
		b	None
7	TAN	-,0,+	Slope of invert of extended model.
8	CRLLOB		Left Overbank reach length in the extended model.
		b	Program will use the channel reach length.
9	CRLCH		Channel reach length in the extended model.
10	CRLROB	+	Right Overbank reach length the in extended model.
		b	Program will use the channel reach length.

**E-4 Manning's n-Value Options (required data)**

Hydraulic roughness is prescribed by Manning n-values. There are four options for each subsection plus a multiplier for the entire cross section: constant n-value for the subsection, n vs Elevation for the subsection, n vs water discharge for the subsection and n vs water depth in the subsection. The multiplier for the cross section is Cowan's coefficient for meander (Chow, 1959). In Version 4.60 and above these options can be used in any combination. However, it remembers the last option read.

**E-4.1 NC-Record - Constant N-Values Plus Expansion/Contraction Coefficients**

The NC-Record prescribes Manning's n-values and expansion/contraction coefficients. The NC-Record values are constant with depth and will be used until changed by the next NC-Record. The n-values apply over the reach. New n-values or Expansion and/or contraction coefficients will be used starting in the reach in which the record appears in the data set. NC-Records may be inserted before any X1-Record. However, when using more than one n value option, insert the NC-Record first

**Note:** HEC-6 applies n-values starting in the reach where the NC-Record appears; whereas HEC-2 applies them halfway to the cross section on either side of the one for which they appear in the data set. However, results using either method are usually in close agreement without changing the n-values.

Example:        FIELDS  
 1234567 1234567 1234567 1234567 1234567 1234567 1234567 1234567  
 NC .15 .15 .025 .1 .3  
 ND 22 .08 .01 .025 .10  
 X1 ...

Field	Variable	Value	Description
0	ICG,IDT	NC	Record identification.
1	XNVR(1)	+	Manning's n-value for the <b>left overbank</b> .
		0	No change from previous n-value for the <b>left overbank</b> .
2	XNVR(3)	+	Manning's n-value for the <b>right overbank</b> .
		0	No change from previous n-value for the <b>right overbank</b> .
3	XNVR(2)	+	Manning's n-value for the <b>channel</b> .
		0	No change from previous n-value for the <b>channel</b> .

**E-4 Manning's n-Value Options - (Continued)**

4	CC	+	<b>Contraction coefficient</b> used in computing transition losses.
		0	No change in contraction coefficient.
5	CE	+	<b>Expansion coefficient</b> used in computing transition losses.
		0	No change in expansion coefficient.
6-10			Leave blank.

**E-4.2 ND-Record - Vary N-Values by Depth (optional)<sup>4</sup>**

A table of Manning's n-values versus depth is entered on the **ND**-Record. The program linearly interpolates when the EFFECTIVE DEPTH is between values specified in the table. Otherwise, this record functions like the NV-Record.

```

Example:           FIELDS
1234567 1234567 1234567 1234567 1234567 1234567 1234567 1234567 1234567 1234567
T3
ND   11   .10
ND   25   0.5   0.5   .023   1   .019   5   .020   12   .021
ND   15
ND   31   .15
X1   ...
    
```

Field	Variable	Value	Description
0	ICG,IDT	ND	Record identification
1	NPAR,NCH	++	Enter subsection number in Column 7 and number of n-values in Column 8. Subsection numbers  In a 3-Strip Model    In a 5-Strip Model 1 = left overbank    1 = left overbank 2 = channel    2 = left bank of channel 3 = right overbank    3 = channel bed 4 = right bank of chan'l 5 = right overbank (For example, 25 denotes that FIVE values are coded for subsection number 2, the channel.)
2	VALN(1)	+	Manning's n-value for smallest depth in the table.
3	ELQ(1)	-,0,+	Enter the depth for VALN(1).
4	VALN(2)	+	Enter the n-value for the next, larger, depth. This can be blank if there is only one n-value for this subsection.
5	ELQ(2)	0,+	Enter the depth for VALN(2).

---

<sup>4</sup> This record is new (Version 4.48).

**NV**

HEC-6 Input Description  
Geometry and Channel Properties

**NV**

**NV-Record - (Continued)**

Field	Variable	Value	Description
6-10			Continue entering values across the record. Up to 5 points are permitted. Code the depth for the fifth n-value in Field 1 of a second <b>ND</b> -Record if five points are required.

**E-4.3 NK-Record - Calculate N-Values (optional)<sup>5</sup>**

Manning's n-values can be calculated with the Brownlie Bed Roughness equations or with the Limerinos Equation. There is a global command, \$K, in Appendix H, "Special Commands and Program Options" which will over-ride the channel n-values prescribed on any N-Record. However, there are cases when it is desirable to prescribe n-values for some cross sections and use the bed roughness predictors for others. The NK-Record offers that flexibility.

Note: Even when these NK-Record(s) are selected, a \$K-Record must be added to the Hydrologic Data Set to prescribe the method for compositing hydraulic parameters. This is particularly important when the model has only 3 Strips (i.e. left overbank, channel and right overbank).

```

Example:           FIELDS
1234567 1234567 1234567 1234567 1234567 1234567 1234567 1234567 1234567 1234567
T3
NC      .1      .1      .025
NKB     2
X1     ...
    
```

Field	Variable	Value	Description
COL 1&2	CLINE	NK	Record identification
COL 3	NPARTY()	B	Calculate bed roughness using Brownlie Equations. (Sand Bed Channels)
		L	Calculate bed roughness using Limerinos Equation (Gravel Bed Channels)
1	NCH	23	The Number of the Channel Strip.
		2	For a 3-Strip Model
		3	For a 5-Strip Model

---

<sup>5</sup> This record is new. (Version 5.07)

**E-4.4 NM-Record - Cowan's M for Energy Loss in Meanders (optional)**

A table of Cowan's m-values versus either elevation, discharge or depth is entered on the **NM-Record**. Code values in the order of **increasing elevation, discharge** or depth. The values on this record will be used until changed by the next **NM-Record**. Program logic is the same as used for N-values.

```

Example:
          FIELDS
          1      2      3      4      5      6      7      8      9      10
1234567 1234567 1234567 1234567 1234567 1234567 1234567 1234567 1234567 1234567
NM  23  1.0    1   1.3   10  1.0   14
X1  ...
    
```

Field	Variable	Value	Description
0	ICG,IDT	NM	Record identification
1	MPARTY,MCH	++	Enter the parameter option number in Column 7 and number of m-values on this record in Column 8.  Parameter options are  2 = m-values are coded versus depth 3 = m-values are coded versus water discharge 4 = m-values are coded versus elevation  (For example, 23 denotes that three m-values are coded, Fields 2, 4, & 6, and the parameter in Fields 3, 5, and 7 is depth.)
2	TABM(1)	+	Cowan's m-value for lowest depth, discharge or elevation in the table.
3	TABM(2)	+	Enter the depth, discharge or elevation value for TABM(1).
4	TABM(3)	+	Enter the next m-value. This can be blank if there is only one m-value for this subsection.
5	TABM(4)	0,+	Enter the depth, elevation or discharge for TABM(3).

**NM**

HEC-6 Input Description  
Geometry and Channel Properties

**NM****NM-Record - (Continued)**

Field	Variable	Value	Description
6-10			Continue entering values across the record. Up to 5 points are permitted. Code the fifth depth, elevation or discharge value in Field 1 of a second NM-Record if five points are required.

**E-4.5 NV-Record - Vary N-Values by Elevation or Discharge (optional)<sup>6</sup>**

A table of Manning's n-values versus either elevations or discharges is entered on the NV-Record. Code values in order of **increasing elevation** or **discharge**. The values on this record will be used until changed by the next NC or NV-Record set. The program linearly interpolates when elevations or discharges are between values specified in the table. When elevations or discharges are outside the range of values specified in the table the extreme values are used, i.e., no extrapolation occurs.

```

Example:           FIELDS
1234567 1234567 1234567 1234567 1234567 1234567 1234567 1234567 1234567 1234567
T3
NV  11      .10
NV  25      .025      .5      .023      5      .019      8      .020      12      .021
NV  15
NV  31      .15
X1  ...
    
```

Field	Variable	Value	Description
0	ICG,IDT	NV	Record identification
1	NPAR,NCH	++	Enter subsection number in Column 7 and number of n-values in Column 8. Subsection numbers  In a 3-Strip Model    In a 5-Strip Model 1 = left overbank    1 = left overbank 2 = channel            2 = left bank of channel 3 = right overbank    3 = channel bed 4 = right bank of chan'l 5 = right overbank  (For example, <b>25</b> denotes that five n-values are coded for subsection number 2, the channel subsection.)
2	VALN(1)	+	Manning's n-value for lowest elevation in the table. A positive (+) n-value denotes that a "n versus elevation" table is being used.

---

<sup>6</sup> This record is different from the HEC-2 program's NV-Record.

**NV-Record - (Continued)**

Field	Variable	Value	Description
		-	Enter the n-value as a negative value for a "n versus discharge" table.
			<b>Note:</b> Do not mix discharges and elevations at the same cross section.
3	ELQ(1)	-,0,+	Enter the elevation for positive VALN(1) or the discharge for the negative VALN(1).
4	VALN(2)	+	Enter the next n-value as + number. This can be blank if there is only one n-value for this subsection.
5	ELQ(2)	0,+	Enter the elevation or discharge for VALN(2).
6-10			Continue entering values across the record. Up to 5 points are permitted. Code the fifth elevation or discharge value as a positive value in Field 1 of a second NV-Record if five points are desired.

**E-4.6 NX-Record - Horizontal Variation of n-Values Option**

The NX-Record allows n-values to be changed at cross section stations. When the program reads an NX-Record, it will immediately composite the distributed n-values into a single n-value, or a table of n-values, for each strip depending on the options coded on the record. The following four methods are provided for calculating the composite n-value:

- 1) Composite by percentage of wetted perimeter
- 2) Composite by the Equal Velocity Method (Horton or Einstein, Chow, 1959)
- 3) Composite by the Equal Force Method (Horton or Einstein Method, Chow, 1959)
- 4) Composite by the Conveyance Method.

The cross section used for compositing is the one following the NX-Record in the Geometric Data File. The NX-Record must be coded for the entire cross section. However, it can be mixed with other n-value record types to provide control over the assignment of n-values.

If the modeler intends to calculate new n-values for all strips using the default NX-Options, then only the number of points and the n-values need to be coded. The default methods are shown below.

```

Example:           FIELDS and COLUMNS ACROSS THE RECORD
0 1           2           3           4           5           6           7           8           9           10
1234567 1234567 1234567 1234567 1234567 1234567 1234567 1234567 1234567 1234567

          DEFAULT COMPOSITE METHOD           = CONVEYANCE, EQUAL VELOCITY, CONVEYANCE.
          DEFAULT N VS DEPTH IN ALL STRIPS  = ND-Record Type
          NUMBER OF (N,D) COORD            = 5
NX      3                                -12391   .140 2078.65   .031 4046.95   .080

X1 423.0           1 2078.65 4046.95   1000   1000   1000

...
    
```

The results are printed in TABLE GEO-6.

TABLE GEO-6. REACH N-VALUES AT CROSS SECTION 423.0						
STRIP NO 1		STRIP NO 2		STRIP NO 3		
CONVEYANCE		EQUAL VEL.		CONVEYANCE		
n	DEPTH	n	DEPTH	n	DEPTH	
2	0.094	7.0	0.031	12.8	0.075	6.0
4	0.117	14.0	0.031	25.5	0.073	12.0
6	0.131	21.0	0.031	38.3	0.079	18.0

8   0.137	28.0   0.031	51.1   0.080	23.9
10   0.139	35.0   0.031	63.8   0.080	29.9
BED   ELEV=	135.0   ELEV=	100.4   ELEV=	141.1

*The ND-Record type is a table of n-value vs depth. HEC-6T offers four options for coding n-values. They are the [NX, ND, NK, NV]-Record. These records are described in Appendix E, "Geometry and Channel Properties."* An ND-table can contain up to 5 n-value points, and the NX-Record default uses all five. The program determines the minimum and maximum elevations in subsection, calculates the total difference and spaces the five points equally. Therefore, the depth will probably be different in each strip. Table GEO-6 shows the Bed Elevation in each strip.

In a 3 strip model the left overbank is strip 1; the channel is strip 2; and the right overbank is strip 3. In a 5-strip model the channel is made up of strips 2, 3 and 4. The strip number for the left overbank is 1, and the right overbank is strip 5.

The NX-Record does not affect how the program combines values from strips 2, 3 and 4 into a single composite for the channel. It only controls how n-values which are distributed across a strip are composited within that strip.

HEC-6T will not abort if NX-Stations fail to match cross section stations, but the calculations do not interpolate at NX-stations. The new n-value starts at the first cross section-station that is equal to or larger than the station read from the NX-Record.

The rules the program uses to apply NX-Record data are consistent with the other record types for prescribing roughness [NC, ND, NK, NT, NV]. The n-value for a strip will remain in use until it is specifically changed by the next n-value record. For example, if new overbank n-values are prescribed for all strips except the channel strip, the program will use channel n-values from the previous cross section.

The intended purposes of the data set are stated on the comment records just above the NX-Record. These comments are for the user's information. They are not read by the program. In the example below, the comment records state:

- 1) In the Left Overbank calculate the composite n-value by default (Conveyance) method and save it as n vs Elevation (See NV-Record). Default to 5 points in the table
- 2) In the channel n-values are read from the NV-Record as an (n, Q) table.
- 3) In the Right Overbank composite the n-value from NX-Record values using percent of wetted perimeter and save the result as NC-Record type.

**NX**

# HEC-6 Input Description Geometry and Channel Properties

**NX**

```

Example:          FIELDS
1234567 1234567 1234567 1234567 1234567 1234567 1234567 1234567 1234567 1234567
T3
PX                .3      .1

```

```

                STRIPS = LEFT OB,          CHANNEL,          RIGHT OB
DEFAULT COMPOSITE METHOD = CONVEYANCE,      EQUAL VELOCITY,      CONVEYANCE.
SAVE RESULTS AS         = (n, ELEV) TABLE, READ NV-RECORD, NC-RECORD TYPE
NUMBER OF POINTS IN TABLE = 5 (n, ELEV),    2 (n, Q),            1 NC VALUE

```

```

NX    5                NE1                0    0.25    10    0.040    19    .015
NX                35    0.040    40    0.30
NV    22    -.025    500    .018    250000
NX                5    NC3

```

```

VALLEY SECTION UPSTREAM OF B-168.85
X1168.90    1    1185    1337    495    495    495

```

The program recognizes each n-value record by its type number. It will use the last Record Type number that it reads as the type for that strip even though other Record types may have been read earlier. Therefore, put the NX-Record first in each data set, and follow it with the other record types as desired.

Field	Variable	Value	Description
0		NX	Record identification.
1	NUMNH		<p>The number of the n-values coded on the NX-Record(s). i.e. the (N-VALUE vs Cross Section Station) coordinate points</p> <p>Code the n-values for the entire cross section on the first NX-Record. Also, code the "Options" data in fields (NX-2, NX-3 and NX-4) as desired for the left overbank strip.</p> <p>If different options are desired for the Channel or the Right Overbank, code each on a new NX-Record. Code only the "Options" portion of the NX-Record. Leave NUMNH and the (n vs station) fields blank. The program will use the n-values that it read from the first NX-Record to make the calculations</p>
2	MCHRUF	+ b,0	<p>Method for calculating Composite n-values for a strip</p> <p>Defaults are Conveyance Method for the Overbanks and Equal Velocity for the channel (See 2 and 4 below)</p>

		2	Equal Velocity Method is used to calculate a composite n-value for the strip.
		3	Equal Force Method is used to calculate the composite n-value for the strip.
		4	Conveyance Method is used to calculate the composite n-value for the strip.
		5	The n-Value is calculated by weighting each n-value by the wetted perimeter over which it applies.
3	TYPEandSTRIP	[NC, ND, NE] [1,5]	Options for saving results are [NC,ND,NE]. The strip numbers are [1,2,3] or [1,2,3,4,5] depending on whether the model contains three or five strips.
		NC	When a Record Type is coded without a strip number, it is applied to all strips.
		NC[1,2,3,4,5]	When both Record Type and Strip Number are coded, the results are assigned to the selected Strip Number. The left overbank is strip 1. The channel is either 2 or 2,3,4; and the Right Overbank is either strip 3 or 5.
			If the Strip Number Option is coded for any strip, then it must be coded for all strips.
			Leave No spaces. Only code 1 strip per NX-Record.
		ND	This uses the rules for an ND-Record. The program will convert the NX values into an (n, Depth) table. The conversion will be made for all strips.
			The depth values in the table can be specified. See EDPAR (NX-4).
			Code ND[1,2,3,4,5] to limit the option to a specific strip number. If one strip is coded, all strips must be coded. Leave no spaces.

		NE	<p>The NE-Option obeys the same rules as the NV-Record with the Elevation Option. The program will convert the NX values into an (n, ELEV) table.</p> <p>The elevation values in the table can be specified. See EDPAR (NX-4)</p> <p>Code NE[1,2,3,4,5] to limit the option to a specific strip number. If one strip is coded, all strips must be coded. Leave no spaces.</p> <p>NOTE: There is no (N, Q) option for an NX-Record.</p>
4	EDPAR		<p>Specify the Elevation or Depth Values for the [NE, ND] options in (NX-3). The NC option does not need a depth or elevation.</p>
		b,0	<p>The program will default to a table of 5 points for ND or NE-Record Types. If the record type is ND, the table will contain (n, Depth) points. If the record type is NE, the table will contain (n, ELEV) points. They will be spaced uniformly between the maximum and minimum elevations in the strip. Enter 0.001 for 0.</p>
		-,+	<p>Code the lowest Depth or Elevation value</p>
		-,+	<p>Code up to five values. Place each value on a New NX-Record.</p>
5	STANH(1)	-,0,+	<p>Code the n-value vs cross station points on the first NX-Record only.</p> <p>The cross section station where the first n-value begins goes in Field 5 .</p>
6	XNNH(1)	+	<p>Code the first n-value in Field 6.</p>
7	STANH(2)		<p>Code the station where the second n-value begins in Field 7.</p>
8	XNNH(2)		<p>Code the second n-value in Field 8.</p>
9	STANH(3)		<p>etc</p>
10	XNNH(3)		<p>etc</p>
0		NX	<p>If there are more than 3 n-values, continue coding in Field 2 of the next NX-Record. (See Example). Up to 100 (n vs Station) points are permitted.</p>

**NX**

HEC-6 Input Description  
Geometry and Channel Properties

**NX**

1		blank	Leave field 1 blank on all continuation records.
2	STANH(4)		
3	XNNH(4)		
4	STANH(5)		
5	XNNH(5)		
...	...		
8	STANH(7)		
9	XNNH(7)		
10	STANH(8)		
0		NX	
1		blank	
2	XNNH(8)		
3	STANH(9)		
4	XNNH(9)		etc

**E-5 Local Inflow/Outflow Options**

Local inflow/outflow points allow tributary or diversion rates to be prescribed without supplying a geometric model. Two options are provided for outflows and one for inflows.

**E-5.1 QP-Record - Local Outflow as Percent**

This record identifies the location of a local outflow point and prescribes the rate as a percentage of the inflowing water discharge to the segment. It should be placed like a QT-Record. (i.e. ... immediately above the X1-Record for the first cross section upstream from the local outflow point.)

```

Example:           FIELDS
1234567 1234567 1234567 1234567 1234567 1234567 1234567 1234567 1234567
X1 1660           10 2582.34 3020.34           500           500           500
X3 10
GR5577.5 2286.19 5578.5 2582.34 5577.78 2585.34 5577.8 2592.34 5577.62 2602.34
GR5580.7 3018.34 5580.8 3020.34 5578.3 3029.08 5580.6 3042.35 5580.5 3055.69
H 1660
QP -10           0           -50           2000
X1 1960           15 2857.84 3291.27           300           300           300
X3 10
GR5582.0 2750.39 5579.1 2768.72 5579.1 2771.91 5578.9 2847.84 5578.9 2857.84
GR5578.3 3262.84 5580.8 3271.84 5581.29 3276.84 5581.8 3291.27 5581.7 3308.30
GR5582.2 3329.02 5586.1 3355.42 5586.6 3371.5 5582.2 3392.08 5581.8 3398.70
H 1960
    
```

Field	Variable	Value	Document
0	ICG,IDT	QP	Record identification.
1	YLOC(1)	- %	Local outflow of water expressed as a percentage of mainstem water inflow to this segment of the model.
2	XLOC(1)	+	Enter the Mainstem Q corresponding to YLOC(1) if the percentage varies with Q. Otherwise, leave the remainder of this record blank.
3	YLOC(2)	-, +	Continue coding up to five points.
4	XLOC(2)		etc

**E-5.2 QT-Record - Local Inflow/Outflow Location (optional)**

This record identifies the location of an inflow or a diversion point. It should be placed immediately before the X1-Record for the first cross section upstream from the local inflow/outflow. The water discharge rate for the QT option is prescribed on the Q-Record in the Hydrologic Data Set. See Chapter 3, Section 3.6.2 in the HEC-6 User's Manual for additional information.

```

Example:          FIELDS
1234567 1234567 1234567 1234567 1234567 1234567 1234567 1234567 1234567
NC      .15      .20      .025      .1      .3
QT
X1      . . .
    
```

Field	Variable	Value	Document
0	ICG, IDT	QT	Record identification.
1	KQCH	b, 1	A local inflow/diversion point occurs just before the cross section on the X1-Record following the QT in the data file.
		<del>2-10</del>	<del>A tributary junction (control) point.</del> This option is obsolete; however, many old data sets which were coded with this option will still run.
2-10			Leave blank.

**Note:** a. When defining a local inflow/outflow point, leave Field 1 blank. Any value greater than KQCH = 1 will indicate a tributary junction point, and that option is not recommended.

~~b. When defining a tributary junction point, a value must be entered in Field 1. This value should be within the range 2 through 10.~~ **NOT FOR HEC-6T**

**E-5.3 QL-Record (optional)**

The QL-Record is a Return-Flow option. It allows a local outflow to Return to the network at another location. The return location can be on the same segment as the outflow; or it can be on a different segment. This simple routing technique solves the Continuity Equation for Water. No energy terms are included.

```

Example:          FIELDS
1234567 1234567 1234567 1234567 1234567 1234567 1234567 1234567 1234567GR    20    101
$SEG  1      2      1
T1
T2
T3
NC
X1
GR
HD
...

X1
GR
HD
QL  2      2      100      1          (Note: This is the Fifth Local Inflow/Outflow
                                        Point on Segment 1. It shows how to Code the
                                        QL-Record to Return Flow from the QP-Record
                                        on Segment 2)
PX          1          3      .000          1000
EJ

$SEG  2      3      2
T1
T2
T3
NC
X1
GR
HD
QL The First Inflow/Outflow Point on Segment 2
X1
GR
HD
QP The Second Inflow/Outflow Point on Segment 2
X1
GR
HD
QT The Third Inflow/Outflow Point on Segment 2
X1
GR
HD
EJ
    
```

**QL**

## HEC-6 Input Description Geometry and Channel Properties

**QL**

Field	Variable	Value	Description
0	ICG, IDT	QL	Record identification.
1	LOCQLN	+	Segment number where the Outflow occurs.
2	LOCQLL	+	Number of the Local Inflow/Outflow Point where the outflow occurs. Note: Local Inflow/Outflow Point Numbers are counted by Segment starting at the downstream end. Each QL- QT-, or QP-Record identifies a Local Inflow/Outflow point (SEE above example).
3	PCTQW		The percentage of the local outflow which returns at this RETRUN flow point. The return flow percentage does not have to sum to 100%
		0,b	The default value is ZERO. This is a valid RETURN flow.
		+	Code the return flow as a percentage of the outflow.
4	IOPQS		These are Option Numbers - not the coefficients, for including sediment in the returning water discharge.
		1	Option 1 will include the entire mass of sediment outflow in the returning water. This option does not reduce the sediment even when the returning water is less than 100% of the outflow.
		2	Option 2 will return Zero Sediment.
		3	A coefficient table was entered in the Sedimentary Data Set (Appendix F, Record Types \$LOCAL..etc, Case 4). The returning mass of sediment is calculated by multiplying the Sediment Outflow Discharge in Tons/Day by the coefficient coded in that Table. There will be a coefficient table for each size class.

**E-6 X1-Record - Cross Section Location (required)<sup>7</sup>**

The X\*-Record Types contain data for cross section controls. The first record is always the X1 Record. It identifies the cross section and prescribe it's distance from the downstream cross section.

```

Example:           FIELDS
1234567 1234567 1234567 1234567 1234567 1234567 1234567 1234567 1234567
NC   .15      .20      .025     .1      .3
X1  1660      10      2582     3020     500     500     500
X3   10
    
```

Field	Variable	Value	Description
0	ICG,IDT	X1	Record identification.
1	SECID	-,0,+	Cross section identification number.
2	NXY	+	Total number of coordinate points used to describe the cross section's geometry on the <b>GR</b> -Records which follow ( $5 \leq NXY \leq 100$ .)
		0	<b>Repeat Cross Section Option.</b> The geometry of the previous (downstream) cross section ( <b>GR</b> -Records) will be repeated for the present cross section. Therefore, no <b>GP</b> -Records will be entered for this section. Do not code a zero for the first cross section.
3	STCHL	-,+	Station of the <b>left</b> bank of the channel, Use top-bank when the bank roughness is included in channel n-values. Toe of bank is recommended when channel bank roughness is included in overbank n-values. STCHL does not need to equal one of the station values entered on the <b>GR</b> -Records for this cross-section.
		0	For a repeat cross section, enter blank or zero (i.e., when NXY ( <b>X1.2</b> ) is zero).
4	STCHR	-,0,+	Station of the <b>right</b> bank of the channel. Same rules as for STCHL above.
5	RLL	+	<b>Reach length</b> of the <b>left</b> overbank between current cross section and the (previous) downstream cross section.

<sup>7</sup> Date Modified: June 11, 1995

## X1-Record (continued)

Field	Variable	Value	Description
		0	Enter zero or leave blank for the first cross section or when there is no left overbank subsection.
6	RLR	0,+	<b>Reach length</b> of the <b>right</b> overbank. Same rules apply as for RLL above.
7	RLC	0,+	<b>Channel Reach Length</b> . The same rules apply as for overbank reach lengths above.
8	RX		<b>Cross Section Width Adjustment Factor</b> . Each GR- station will be <b>multiplied</b> by RX. For a repeat cross section, GR stations from the previous cross section will be changed before they are reused. <sup>8</sup>
		b, 0	No change to cross section stations.
		0<RX<1	The cross section width is reduced.
		RX > 1	The cross section width is increased
9	DH		<b>Cross Section Elevation Adjustment Factor</b> . The constant DH will be <b>added</b> to each elevation on the GR-Records for this cross section. For a repeat cross section, elevation values from the previous cross section will be changed before they are reused. <sup>9</sup>
		b,0	No change to cross section elevations.
		+	Constant will be added to all elevations.
		-	Constant will be subtracted from elevations.

---

<sup>8</sup> The left and right channel stations, left and right conveyance limits, ineffective area limits, left and right movable bed limits, left and right erosion limits, and left and right limits of the dredged channel will all be adjusted by RX.

<sup>9</sup> If NV-Records are present, **elevations** will be changed, but the dredging template elevation, EDC, (H-Record series ) is not changed.

**E-7 XB-Record - Separate Channel Bed from Banks (optional)**

The XB-Record partitions the model into 5 strips. Three of these form the channel subsection. That is, the **XB**-Record allows the top of bank station and the toe of bank station to be prescribed for the left and right channel banks. The bed roughness can then be computed separately from bank roughness using Brownlie or Limerinos roughness predictors; or it can be prescribed with Manning n-values. A composite channel n-value is calculated from the three strip values.

By default the program will assign the channel reach length to all three strips in the channel subsection. Use the XC-Record to override that default.

The program does not default n-values to the three strips in the channel. The program will default to the Alpha Method for calculating the composite channel conveyance when n-values are prescribed on HD-, NH- or NV-Records. When NK-Records are used, the program will default to the Einstein-Horton (i.e. Equal Velocity) method for compositing bed and bank roughness. However, if the channel width/depth ratio is less than 20, the Einstein-Horton method is recommended for calculating the composite channel conveyance. Use the \$K[I, B, L]-Record in **SPECIAL COMMANDS AND PROGRAM OPTIONS** to prescribe the method for calculating composite channel conveyance.

When no compositing is requested, the hydraulic parameters for sediment calculations are from the channel bed strip.

```

Example:           FIELDS
1234567 1234567 1234567 1234567 1234567 1234567 1234567 1234567 1234567 1234567
XB  1500   1540   2200   2250   7500
XC   ...
X3   ...
XL   ...
GR   ...
    
```

Field	Variable	Value	Description
0	ICG,IDT	XB	Record identification.
1	STA(1)	+	Top of left bank (Old STCHL)
2	STA(2)	+	Toe of left bank.
3	STA(3)	+	Toe of right bank. The program assigns the channel to this strip (i.e. strip 3).

**XB-Record (continued)**

Field	Variable	Value	Description
4	STA(4)	+	Top of right bank (Old STCHR)
5	STA(5)	+	End of cross section station
6	...	...	UP TO 7 STRIPS ARE PERMITTED. Must have same number at each cross section
9	BKSLO	b,+	Program uses BKSLO to test cross section for Toe of Banks. Default is 0.2 (i.e. 1:5) It sweeps down from Top Bank to locate the Toe
10	CHST	+	Channel station if not STA(3)

**E-8 XC-Record - Reach Lengths for XB-Record**

The **XC**-Record allows reach lengths to be assigned to each subsection on the **XB**-Record. Do not use a **XC**-Record without a **XB**.

```

Example:           FIELDS
1234567 1234567 1234567 1234567 1234567 1234567 1234567 1234567 1234567 1234567
XB  20      18      1500    2250    1320    1320    1320
XB 1500    1540    2200    2250    7500
XC 1000    1100    1200    1300    1500
XB  10      10
XL  ...
GR  ...
    
```

Field	Variable	Value	Description
0	ICG,IDT	XC	Record identification.
1	RL(1)	+	Reach length of left overbank.
2	RL(2)	+	Reach length of left bank of channel.
3	RL(3)	+	Reach length of channel.
4	RL(4)	+	Reach length of right bank of channel.
5	RL(5)	+	Reach length of right overbank.

**E-9 X3-Record - Ineffective Flow and Encroachments (optional)**

The **X3**-Record provides three methods for defining encroachments to a cross section. These methods are: (1) ineffective flow area, defined using Field 1; (2) effective width, defined using Field 3; and (3) encroachment stations, defined using Fields 4-7. The HEC-6 **X3**-Record is different from the HEC-2 **X3**-Record.

```

Example:           FIELDS
1234567 1234567 1234567 1234567 1234567 1234567 1234567 1234567 1234567 1234567
X1      20      18      1500      2250      1320      1320      1320
XB     1500     1540     2200     2250     7500
XC     1000     1100     1200     1300     1500
X3      10
XL      ...
GR      ...
    
```

Field	Variable	Value	Description
0	ICG,IDT	X3	Record identification.
1	MEID		<b>Method 1.</b> Ineffective flow area option.
		10	All water is confined to the channel, as defined by variables STCHL and STCHR on the <b>X1</b> -Record, until the calculated water surface elevation exceeds the channel bank elevation (the elevations corresponding to STCHL and STCHR on the <b>X1</b> -Record). The rest of this record may be left blank.
		0	Method 1 is not used. See other methods below.
2			Leave blank.
3	ENCFP		<b>Method 2.</b> Effective width for all flow.
		+	The program confines all flow to the width specified by ENCFP. It will be centered using the left and right bank stations of the channel (STCHL and STCHR on <b>X1</b> -Record). Side boundaries will be vertical and frictionless. Method 2 may be used in conjunction with Method 1.
		0	The width option is not being used or is not changed from previous value.

## X3-Record - (Continued)

Field	Variable	Value	Description
4	STENCL	-,+	<p><b>Method 3.</b> Station of Encroachment, left side of cross section. <b>Method 3 may not be used in conjunction with Methods 1 and/or 2.</b></p> <p>STENCL sets a limit for flow on the <b>left</b> side of the cross section. The side will be vertical and frictionless unless ELENCL is also used (see Field 5 below).</p> <p><b>Note:</b> Do not enter a station value of zero since it will be treated as if no value was entered. Enter a small positive number like 0.01 instead.</p>
5	ELENCL	-,+	<p><b>Method 3.</b> Elevation of encroachment, left side of cross section. All cross section elevations for stations to the left of STENCL are raised to this elevation.</p> <p>Enter the elevation at the top of encroachment.</p> <p><b>Note:</b> Do not enter a value of zero since it will be treated as if no value was entered as cautioned above.</p>
6	STENCR	-,+	<p><b>Method 3.</b> Encroachment station right. (SEE STENCL AND ELENCL above.)</p> <p>Same rules and purpose as STENCL-- but for use on the <b>right</b> side of the channel.</p>
7	ELENCR	-,+	<p><b>Method 3.</b> Elevation of Encroachment, right side of cross section.</p> <p>Same rules and purpose as ELENCL but for use on the <b>right</b> side of the channel.</p>
8	ELLEA	-,+	<p><b>Method 4.</b> Elevation of ineffective flow area, Left Overbank. This option works with MEID=10 when the elevation of the channel station is not a satisfactory measure of ineffective flow area. If this option is selected, then ELREA SHOULD BE USED, also.</p>
9	ELREA	-,+	<p><b>Method 4.</b> Elevation of ineffective flow area, Right Overbank. SEE ELLEA above; if this option is selected, then ELLEA SHOULD BE USED, also.</p>

**E-10 X5-Record - Hydraulic Control Point (optional)<sup>10</sup>**

This record is useful when locating cross sections very close together such that reach length might become a limiting factor in the computation time step. It breaks the geometric segment into sub-segments, and no computations are made in the reach. Sediment leaving the upstream sub-segment is simply passed into the downstream sub-section without change.

Field	Variable	Value	Description
0	ICG, IDT	X5	Record identification.
1			Leave blank.
2	UPE	-, +	<b>Method 1 - Internal Operating Rule.</b> The water surface elevation at this cross section will be UPE unless the water surface at the downstream section plus HLOS exceeds UPE. (HLOS is coded in Field 3.)
		0	Zero indicates that Method 1 is not used. If the desired water surface elevation is zero, enter a small positive value (e.g., 0.001).
3	HLOS	0, +	<b>Head loss</b> between this section and the cross section immediately downstream. The UPE water surface elevation is overridden when the tailwater elevation plus HLOS is higher.

---

<sup>10</sup> The HEC-6 X5-Record is different from the HEC-2 X5-Record.

**E-11 XL-Record - Conveyance and Cross Section Limits (optional)**

Two concepts are provided for restricting calculations to a portion of a cross section. These are "Conveyance Limits" and "Cross Section Limits."

*Conveyance Limits.* In HEC-6T, only hydraulic loss computations are restricted by conveyance limits. Bed erosion limits are prescribed on the HE-Record. In HEC-6W, prescribing conveyance limits restricts hydraulic loss and bed erosion computations while allowing bed deposition and water storage computations to extend across the entire cross section.

Two methods are available for specifying conveyance limits.

Method 1 - prescribe the conveyance width and it will be positioned in the cross section by centering its midpoint halfway between the left and right bank stations which are prescribed on the **X1**-Record. The conveyance limit can fall outside of the channel stations, however.

Method 2 - both a left and right station must be prescribed.

*Cross Section Limits.* Enter a Start Station and/or an End Station and all computations are restricted between those limits of the cross section.

```

Example:           FIELDS
1234567 1234567 1234567 1234567 1234567 1234567 1234567 1234567 1234567 1234567
NC .125   .125   .03
X1 20.07   90 10418.8 10493.6   1500   2200   3390           -0.5
X3  10
XL
GR 290   6550   285   8350   285   8500   280   8650   275   8800
GR  ...

```

Field	Variable	Value	Description
0	ICG,IDT	XL	Record identification.
1			Leave blank.
2			Leave blank.
3	CLC	+	<b>Method 1.</b> Enter the width of the conveyance channel. I
		0	Use Method 2.

**XL-Record - (Continued)**

Field	Variable	Value	Description
4	CLL	-,+	<p><b>Method 2.</b> Enter the cross section station for the <b>left</b> side of the conveyance channel. It does not have to coincide with a <b>GR</b> station point. It can be any place in the cross section, but it must be less than CLR.</p> <p><b>Note:</b> Do not enter a value of zero since it will be interpreted as if no value were entered. Enter a small positive number (e.g., 0.001) when a value of zero is desired.</p>
5	CLR	-,+	<p><b>Method 2.</b> Enter the cross section station on the right side of the conveyance channel. Same conditions as CLL.</p>
6	STST	-,+	<p>Start Station for all computations. GR stations less than STST are ignored.</p>
7	ENST	b,0	Computations start at first point in the cross section
		-,+	End Station for all computations. SEE STST
8	CLEP()	b,0	Computations stop at last point in the cross section
		-,+	Conveyance limits, CLL and CLR, applies below this elevation. No limit above this elevation.
9	CLQP()	b,0	No restriction on CLL or CLR limits.
		-,+	Same type control as CLEP except the parameter is Water Discharge rather than Elevation.

**E-12 GE-Record - Cross Section Coordinate Editor**

The GE-Record activates a cross section coordinate editor which reads partially full GR-Records and links together the coordinate points to form the cross section. Blank coordinates are ignored. The GR Stations must still increase in magnitude even when the GE-Record is used. That is, edit the GR-Records to insert new stations so the Station values increase in magnitude.

Place the GE-Record immediately before the GR data set needing the editor. Place a GE-Record at each cross section where the editor is needed.

The number of coordinate points is counted by the program, but always prescribe a positive value on the X1-2 record (i.e. NXY = 1 in the following example) else the program will reuse the GR-Records from the previous cross section.

```

Example:           FIELDS
1234567 1234567 1234567 1234567 1234567 1234567 1234567 1234567 1234567 1234567

X1   20      1      2      810    1000    1000    1000
XB   2       30     800     810    11000
XC  1000    1000    1000    1000    1000
X3   10
GE
GR   334      0     334      2
GR                                     321      3     321     800
GR   334     810
GR   350    11000
HD   20      10
HE   20
    
```

**E-13 GR-Record - Cross Section Coordinates (required)**

The data entered on the **GR**-Records is used to specify the cross section's two dimensional geometry in terms of a set of Y-X coordinate points. These coordinate points correspond to the elevation (Y) and station (X) along the cross section's ground profile. A set of **GR**-Records is required to each cross section unless NXY (**X1.2**) is zero (or blank) indicating a repeat cross section. Code stations in increasing order. Enter five elevation/station pairs per **GR**-Record. A maximum of 100 points (or twenty **GR**-Records) per cross section is permitted.

```

Example:           FIELDS
1234567 1234567 1234567 1234567 1234567 1234567 1234567 1234567 1234567 1234567
NC  .125   .125   .03
X1 20.07   90 10418.8 10493.6   1500   2200   3390           -0.5
X3   10
XL
GR 290   6550   285   8350   285   8500   280   8650   275   8800
GR  ...
    
```

Field	Variable	Value	Description
0	ICG,IDT	GR	Record identification.
1	EL(1)	-,0,+	Elevation of first coordinate point.
2	STA(1)	-,0,+	Station of first coordinate point.
3	EL(2)	-,0,+	Elevation of second coordinate point.
4	STA(2)	-,0,+	Station of second coordinate point.
5 - 10			Etc., continue for up to 100 coordinate point pairs. Each continuation record is identified with <b>GR</b> in Field 0, and the format is identical for all records.

**E-14 The Bed Sediment Reservoir (Required Data)**

There are four options for prescribing the size of the bed sediment reservoir (H-, HD-, HL- and HI- ), and one for limiting the width of erosion (HE-). The H- and HD are similar in that the only difference is Field 2. The H- prescribes the elevation of the bottom of the sediment reservoir and the HD prescribed the depth of sediment in the sediment reservoir in that field. The H-Record defaults to a depth of 10.0, and the HD defaults to 0. feet of depth. Use which ever is more convenient for the condition being modeled.

The HL and HI-Records differ from the H-Record in Fileds 2 and 9. These records are the same as the HD- in field 2, but they permit prescribing more than one dredging site in field 9. More than one site can be important for summarizing results and for prescribing different dredging rates.

Finally, the HI-Record differs from the HL in that the cross section stations prescribed in fields 7 and 8 are physically inserted into the cross section array, along with a value 20 feet on either side, to form the dredge channel template. None of the other bed sediment reservoir records physically modify the cross section coordinates.

**E-14.1 H-Record - Elevation Option for Prescribing Bed Sediment Reservoir**

This is the original HEC-6 record for prescribing the width and depth of the bed sediment reservoir and the dredging template at a cross section. The program computes the depth of sediment in the bed as  $DLY = YMIN - EMB$  where YMIN is the lowest bed elevation in the bed sediment reservoir and EMB is defined in Field 2 of this H-Record. Other records have been added to the H-series, but this H-Record is still acceptable. It allows the user to default the depth of the bed sediment reservoir to 10 feet by leaving Field 2 blank. Other data on this record are the same as the HD-Record. Use only one H- HD- HI- or HL-Record at a cross section, but it is appropriate to include an HE (Erosion Limit) record with any of these H-Records.

```

Example:           FIELDS
1234567 1234567 1234567 1234567 1234567 1234567 1234567 1234567 1234567 1234567
NC  .125   .125   .03
X1  4.1    90 10418.8 10493.6   1500   2200   3390           -0.5
X3   10
XL
GR  290   6550   285   8350   285   8500   11000   8650   275   8800
GR  . . .
H   4.1           10120  10490
HE
    
```

## H Record - (Continued)

Field	Variable	Value	Description
0	ICG	H	Record identification.
1	SECID	-,+	Cross Section identification Number. Use the same value as previously entered in <b>X1.1</b> for this cross section.
2	EMB		Elevation of Model Bottom (EMB) is used to calculate the depth of sediment material in the bed sediment reservoir at this cross section. EMB can be used to prescribe the elevation of geologic or concrete channel controls.
		-,+	Enter the desired elevation. Program will not scour bed below this elevation. Beware, a large depth of sediment can cause calculated volumes to be too large for computer word lengths, resulting in program failure.
		0	Program assigns EMB at 10 feet below the thalweg.
3	XSM		Movable Bed Boundary, Left. Cross section station at change from fixed to movable bed boundary: counterpart to XFM ( <b>H.4</b> ). Elevations at cross section coordinates between XSM and XFM will be adjusted vertically up or down for scour and deposition.
		-,+	Enter the station, left side of channel, where the fixed bed stops and the movable bed begins. This station need not coincide with an existing <b>GR</b> station point.
		0	Program will automatically set the movable bed limits according to the location of the water surface.
4	XFM		Movable Bed Boundary, Right. Cross section station at change from movable to fixed bed boundary, counterpart to XSM ( <b>H.3</b> ).
		-,+	Enter the station of the last movable bed point on the right side of channel.
		0	Program will automatically set the movable bed limits according to the location of the water surface.
5	DLYR		Elevation correction for movable bed at restart.

## H Record - (Continued)

Field	Variable	Value	Description
		-,+	In restarting a run it is desirable to enter a value for DLYR, causing program to correct all <b>GR</b> elevations within the movable bed limits by adding this value to the Y-coordinate.
		0,b	In most cases, leave this field blank.
6	EDC	-,+	Elevation of Bottom of Dredged Channel. Do not include over dredging here (see <b>H.10</b> ). This value should always be above the model bottom. (EMB in Field <b>H.2</b> )
		0	Dredging is not desired at this cross section. If the desired elevation of the dredged channel bottom is zero, enter a small positive value (e.g. 0.001).
7	XSD		Dredged Channel Boundary, Left. The cross section station where dredging will begin if this value equals a station coded on the <b>GR</b> -Records. If it does not coincide with a <b>GR</b> station, dredging will begin at the next <b>GR</b> station after the value coded here. No new cross section station is interpolated.
		-,+	Enter the station of the cross section coordinate point on the left side of the dredged channel. This value should be equal to or greater than XSM.
		b,0	XSD is set equal to XSM ( <b>H.3</b> ).
8	XFD		Dredged Channel Boundary, Right. Cross section station beyond which no dredging is performed, counterpart to XSD.
		+	Enter the station of the cross section coordinate point at the right of dredged channel. XFD should always be less than or equal to XFM.
		0	Either no dredging is required or XFD=XFM ( <b>H.4</b> ).
9	XDM		Cross section station of highest elevation inside the dredge template. It is used to test the elevation of that point against the elevation of dredged channel to determine whether or not dredging is required.
		+	Enter the X-coordinate of the coordinate point having the highest elevation within the portion of channel to be dredged.

**H Record - (Continued)**

Field	Variable	Value	Description
		0	Program uses the first (left-most) station within the dredged channel portion of the cross section.
10	DOD		Depth of Over dredging. Used to establish some extra depth below the required bottom elevation.
		+	Enter the amount of over dredging desired at this cross section. Do not allow over depth dredging below the bottom of the bed-sediment reservoir.
		0,b	Leave blank if over dredging is not required.

**E-14.2 HD-Record - Depth Option for Prescribing Bed Sediment Reservoir**

This record prescribes the width and depth of the bed sediment reservoir and the dredging template at a cross section. It replaces the **H**-Record and allows the depth of sediment in the bed to be prescribed directly with the variable **DLY** (**HD.2**) instead of implying it through the elevation of the model bottom, using **EMB** (**H.2**). All other fields of the **HD**-Record are the same as those on the **H**-Record and either record is acceptable to the program. Use only one **H**- **HD**- **HI**- or **HL**-Record at the same cross section, but it is appropriate to include an **HE**-Record with any of these **H**-Records.

```

Example:           FIELDS
1234567 1234567 1234567 1234567 1234567 1234567 1234567 1234567 1234567 1234567
NC .125 .125 .03
X1 4.1 90 10418.8 10493.6 1500 2200 3390 -0.5
X3 10
XL
GR 290 6550 285 8350 285 8500 280 8650 275 8800
GR ...
HD 4.1 10 10120 10490
HE
    
```

Field	Variable	Value	Description
0	ICG, IDT	HD	Record identification.
1	SECID	-, +	Cross Section Identification Number. Use the same value as previously entered in <b>X1.1</b> -Record for this cross section.
2	DLY	0, +	Depth of the Bed Sediment Reservoir at this cross section. Negative values are not permitted. There is no default. Blank is the same as zero.
3	XSM	-, +	Movable Bed Boundary, Left. Cross section station at change from fixed to movable bed boundary; counterpart to <b>XFM</b> ( <b>HD.4</b> ). Elevations at cross section coordinates will be adjusted vertically up or down for scour and deposition when the <b>GR</b> station falls between <b>XSM</b> and <b>XFM</b> .
		0	Program will automatically set the movable bed limits according to the location of the water surface.

HEC-6 Input Description  
Geometry and Channel Properties

Field	Variable	Value	Description
4	XFM		Movable Bed Boundary, Right. Cross section station at change from movable to fixed bed boundary, counterpart to XSM ( <b>HD.3</b> ).
		-,+	Enter the station of the last movable bed point on the right side of channel.
		0	Program will automatically set the movable bed limits according to the location of the water surface.
5	DLYR		Elevation correction for movable bed at restart.
		-,+	In restarting a run it is desirable to enter a value for DLYR, causing the program to correct all <b>GR</b> elevations within the movable bed limits by adding this value to the Y-coordinate.
		0,b	In most cases, leave this field blank.
6	EDC	-,+	Elevation of Bottom of Dredged Channel. Do not include over dredging here (see <b>HD.10</b> ). this value should always be above the model bottom.
			Note: The bottom of the bed sediment reservoir is $YMN - DLY = EMB$ , where YMN is the lowest elevation in the movable bed portion of the <b>GR</b> data and DLY is ( <b>HD.2</b> ) above.
		0	Dredging is not desired at this cross section. If the desired elevation of the dredged channel bottom is zero, enter a small positive value (e.g. 0.001).
7	XSD		Dredged Channel Boundary, Left. The cross section station where dredging will begin if this value equals a station coded on the <b>GR</b> -Records. If it does not coincide with a <b>GR</b> station, dredging will begin at the next <b>GR</b> station after the value coded here. This value should be equal to or greater than XSM. No new cross section station is interpolated.
		-,+	Enter the station of the cross section coordinate point on the left side of the dredged channel, so that the elevation of coordinate points within the dredge channel (from XSD to XFD, <b>HD.8</b> ) can be corrected for dredging. XSD should always be greater than or equal to XSM.
		b,0	XSD is set equal to XSM ( <b>HD.3</b> ).

HEC-6 Input Description  
Geometry and Channel Properties

Field	Variable	Value	Description
8	XFD		Dredged Channel Boundary, Right. Cross section station beyond which no dredging is performed, counterpart to XSD.
		-.+	Dredging will stop at the <b>GR</b> station equal to, or to the left of this station. This value should be less than or equal to XFM.
		b,0	XFD is set equal to XFM ( <b>HD.4</b> ).
9	XDM		The station of the cross section coordinate point having the highest elevation within the dredged channel. This is the station used to test whether or not dredging is required.
		0	The program uses the left-most point inside the dredging template.
10	DOD		Depth of Over dredging. Used to establish some extra depth below required bottom elevation.
		+	Enter the amount of over dredging desired at this cross section. Do not allow over depth dredging below the bottom of the bed-sediment reservoir.
		0,b	The default for over depth dredging is zero.

**E-14.3 HE-Record - Erosion Limits (optional)<sup>11</sup> HE-Record - Erosion Limits (Optional).** Erosion Limits restrict bed erosion while allowing deposition to extend to the limits of the movable bed. The HE-Record is optional. If it is omitted from the input data set, the limits of erosion are the same as the limits of deposition. If a blank HE-Record is included in the data set, the limits of erosion are set just inside the left and/or right channel stations on the X1-Record. If values are coded on the HE-Record, they must be within the limits of the movable bed.

Place the HE-Record last in the [[H, HD, HL, HI]-, HE]-Record types.

```

Example:
          FIELDS
1234567 1234567 1234567 1234567 1234567 1234567 1234567 1234567 1234567 1234567
NC  .125  .125  .03
X1  4.1   90 10418.8 10493.6 1500 2200 3390 -0.5
X3   10
XL
GR  290  6550  285  8350  285  8500  280  8650  275  8800
GR  ...
HD  4.1   10
HE  4.1           10420  10490
X1  ...
    
```

Field	Variable	Value	Description
0	ICG, IDT	HE	Record identification
1	ISI()		Cross Section Identification
2			Leave blank.
3	EROL	-,+	Enter the cross section station at the left side of the limit of erosion. It does not have to coincide with a GR station, but if it does not, the erosion will begin at the first GR station after EROL.
		Blank	Program will use Left Channel Station + 0.01
4	EROR	-,+	Enter the cross section station at the right side of the limit of erosion. It does not have to coincide with a coordinate point, but if it does not, erosion will cease at the last GR station prior to EROR.
		Blank	Program will use Right Channel Station - 0.01
5	SIDER()	-	Subsidence Rate in Feet/Year
		+	Rebound Rate in Feet/Year
		Blank, 0	No subsidence or rebound

<sup>11</sup> This record was re-designed in September 1995. All previous HE-Records must be re-coded.

**HD**

HEC-6 Input Description  
Geometry and Channel Properties

**HD**

Field	Variable	Value	Description
6 - 10			Leave Blank

**E-14.4 HI-Record - Add Stations Option for Prescribing Bed Sediment Reservoir**

This record can be used in place of the HD-Record. It prescribes the width and depth of the bed sediment reservoir like an HD-Record does, but handles dredging differently. The HI-Record interpolates four points for the dredging template, and it allows the dredging site number to be prescribed. None of the other records in the H-series insert points for the dredging template. They just use the points available in the GR-Records. Use only one H- HD- HI- or HL-Record at the same cross section, but it is appropriate to include an HE-Record with any of these H-Records.

```

Example:           FIELDS
1234567 1234567 1234567 1234567 1234567 1234567 1234567 1234567 1234567 1234567
NC .125 .125 .03
X1 4.1 6 -100 100 1500 2200 3390 -0.5
X3 10
GR 50 -200 50 -100 0 -99 0 99 50 100
GR 50 200
HI 4.1 10 -99.5 99.5 -1 -50 50 1
HE
    
```

Field	Variable	Value	Description
0	ICG,IDT	HI	Record identification.
1	SECID	-,+	Cross Section Identification Number. Use the same value as previously entered in <b>X1.1</b> -Record for this cross section.
2	DLY	b,0,+	Depth of the Bed Sediment Reservoir at this cross section. Negative values are not permitted. Blank is the same as zero.
3	XSM	-,+	Movable Bed Limit, Left; counterpart to XFM ( <b>HD.4</b> ). Enter the station, left side of channel, where the fixed bed stops. The next <b>GR</b> station will be in the bed sediment reservoir.
		0	Program will automatically set XSM equal to the first GR-Station.
4	XFM	-,+	Movable Bed Limit, Right; counterpart to XSM. Enter the station of the first fixed point on the right side of channel.

HEC-6 Input Description  
Geometry and Channel Properties

Field	Variable	Value	Description
		0	Program will automatically set XFM equal to the last GR-Station.
5	DLYR		Elevation correction for movable bed. It is sometimes desirable to modify bed elevations and restart a run. If so:
		-,+	Enter a value for DLYR and the program will add this value to the Y-coordinates within the movable bed.
		0,b	In most cases, leave this field blank.
6	EDC	-,+	Elevation of Bottom of Dredged Channel. This value should always be greater than or equal to YMIN - DLY where YMIN is the lowest bed elevation in the bed sediment reservoir. ( Do not include over dredging here (see <b>HI.10</b> ).
7	XSD		Beginning of Dredging Template, Left side. The program will insert this station into the cross section data set, and it will insert another station at XSD - 20 to form the left side of the trapezoidal dredging template.
		-,+	Enter the station of the left side of the dredged channel. Thging Tem45((ged Chantrapezoidal dredging template.

**HI**

## HEC-6 Input Description Geometry and Channel Properties

**HI**

Field	Variable	Value	Description
		+	Enter the amount of over dredging desired at this cross section. Do not enter over depth dredging below the bottom of the bed-sediment reservoir, (i.e. EMB).
		0,b	The default is zero over depth dredging.

**E-14.5 HL-Record - Multiple Dredging Sites**

This record prescribes the width and depth of the bed sediment reservoir and the dredging template at a cross section. It replaces the **HD**-Record and allows different dredging sites (HL-9). All other fields of the **HL**-Record are the same as those on the **HD**-Record and either record is acceptable to the program. Use only one H-**HD**- **HI**- or **HL**-Record at the same cross section, but it is appropriate to include an **HE**-Record with any of these H-Records.

```

Example:           FIELDS
1234567 1234567 1234567 1234567 1234567 1234567 1234567 1234567 1234567 1234567
NC  .125   .125   .03
X1  4.1    90 10418.8 10493.6   1500   2200   3390           -0.5
X3   10
XL
GR  290   6550   285   8350   285   8500   280   8650   275   8800
GR  . . .
HD  4.1    10  10120  10490
HE
    
```

Field	Variable	Value	Description
0	ICG, IDT	HL	Record identification.
1	SECID	-,+	Cross Section Identification Number. Use the same value as previously entered in <b>X1.1</b> -Record for this cross section.
2	DLY	0,+	Depth of the Bed Sediment Reservoir at this cross section. Negative values are not permitted. There is no default. Blank is the same as zero.
3	XSM	-,+  0	Movable Bed Limit, Left; counterpart to XFM ( <b>HD.4</b> ).  Enter the station, left side of channel, where the fixed bed stops. The next <b>GR</b> station will be in the bed sediment reservoir.  Program will automatically set XSM equal to the first GR-Station.
4	XFM	-,+	Movable Bed Limit, Right; counterpart to XSM.  Enter the station of the first fixed point on the right side of channel.

## HL-Record - Multiple Dredging Sites (Continued)

Field	Variable	Value	Description
		0	Program will automatically set XFM equal to the last GR-Station.
5	DLYR	-,+	Elevation correction for movable bed. It is sometimes desirable to modify bed elevations and restart a run. If so: Enter a value for DLYR and the program will add this value to the Y-coordinates within the movable bed.
		0,b	In most cases, leave this field blank.
6	EDC	-,+	Elevation of Bottom of Dredged Channel. This value should always be above the model bottom.
		0	Dredging is not desired at this cross section. If the desired elevation of the dredged channel bottom is zero, enter a small positive value (e.g. 0.001).
7	XSD	-,+	Dredged Channel Boundary, Left. The cross section station where dredging will begin if this value equals a station coded on the <b>GR</b> -Records. If it does not coincide with a <b>GR</b> station, dredging will begin at the next <b>GR</b> station after the value coded here. This value should be equal to or greater than XSM. No new cross section station is interpolated.
		b,0	XSD is set equal to XSM ( <b>HD.3</b> ).
8	XFD	-,+	Dredged Channel Boundary, Right. Cross section station beyond which no dredging is performed, counterpart to XSD. Dredging will stop at the <b>GR</b> station equal to, or to the left of this station. This value should be less than or equal to XFM.
		b,0	XFD is set equal to XFM ( <b>HD.4</b> ).
9	NDRR()		The dredging site number. Enter a value from 1 to 10.

**HL-Record - Multiple Dredging Sites (Continued)**

Field	Variable	Value	Description
		0	The default is NO DREDGING at this cross section.
10	DOD		Depth of Over dredging. Used to establish some extra depth below required bottom elevation.
		+	Enter the amount of overdredging desired at this cross section. Do not enter over depth dredging below the bottom of the bed-sediment reservoir, (i.e. EMB).
		0,b	The default is zero over depth dredging.

HEC-6 Input Description  
Geometry and Channel Properties

**E-15 EJ-Record (required)**

End of geometric model data is established by an **EJ**-Record. This record must be the last geometry record entered for each stream segment described in the geometry section.

```

Example:           FIELDS
1234567 1234567 1234567 1234567 1234567 1234567 1234567 1234567 1234567 1234567
X1  4.1      90 10418.8 10493.6   1500   2200   3390                -0.5
X3   10
XL
XL                11000
GR  290     6550     285    8350     285    8500     280    8650     275    8800
GR   ...
HD  4.1      10  10117   10449
HE
EJ
$SEG ...

```

Field	Variable	Value	Description
0	ICG, IDT	EJ	Record identification.
1-10			Leave blank.

**NOTE: The \$TRIB-Record is not used in Version 4.00 and higher. It is only included here because some historical data sets utilized this record. Those historical data sets may require modification.**

**E-16      \$TRIB-Record - Tributary Inflow Point (optional)**

This is the HEC-6 record which identifies the beginning of the geometry or sediment data set for each tributary in the stream network. The difference between a tributary and a local inflow is that the tributary is a branch in the network geometry data set whereas a local inflow point has no geometry. Refer to Chapter 3, Section 3.6 of the HEC-6 User's Manual for instructions on assembling data for tributary systems.

Place a \$TRIB command in front of each tributary geometry data set and in front of each tributary sediment data set.

Note: A \$TRIB-Record for versions of HEC-6 after 1984 has a different meaning than a \$TRIB-Record for versions between 1972 and 1986. A \$TRIB-Record from a data file setup to run under the prior version (all versions dated prior to October 1986) should be changed to a \$LOCAL-Record in order to run the identical data file using this version. Many geometric sets from the time period 1986 to 1994 which contain \$TRIB AND CP-RECORDS will still run in HEC-6T, but **they ARE NOT the recommended data structure** for new data sets. Use the \$SEG-Record instead.

Field	Variable	Value	Description
0	ICG,IDT	\$TRIB	Record identification (Columns 1 -5).

**E-17 CP-Record - Control Point Identification (optional)**

A CP-Record was used in historical data sets to form the structure of the network. The value entered in Field 1 was the control point number for the segment number coded on the Q-Record. A CP-Record followed each \$TRIB-Record in the geometry data set. Version 4.00 of HEC-6 will still read that historical data structure and perform the calculations being requested on those historical data sets, but the new options in HEC-6T can not be used with those old data sets.

The CP-Record is also used with features in Version 4.00. For example, the \$PRINT Option and the \$BASIN Option use a CP-Record to prescribe the control point number and the segment number for their data sets. The Sedimentary Data uses a CP-Record to locate the control point for sediment inflow tables.

Field	Variable	Value	Description
0	ICG, IDT	CP	Record identification.
1	NCP	+	Control Point Number.
		b	In this case, the program only uses the Stream Segment Number so NCP can be left blank.
2	NGDS	+	Stream segment number.

## **APPENDIX F**

### **INPUT DESCRIPTION FOR SEDIMENTARY DATA**



Sediment Properties and Transport Functions

**INPUT DESCRIPTION FOR SEDIMENTARY DATA**

**F-1 Title Records - Comments (five required - T4 - T8)**

**Five Title Records are required** to precede the sediment data for **each segment** in the network. They each have a T in Column 1 and the sequence number in Column 2. The number four is suggested for the first sequence number. A Data Echo print option is available; see below for details.

**Note:** Column 4 of **T4**-Record reserved for program use.

```

Example:          FIELDS
1234567 1234567 1234567 1234567 1234567 1234567 1234567 1234567 1234567 1234567
EJ
T4      THE TITLE RECORDS MAY CONTAIN ANY ALPHA-NUMERIC DATA  AFTER COLUMN 4 .
T5      SUGGEST SUCH AS DATE AND SOURCE OF SED SAMPLES.  PLAN-MODEL RUN NO
T6      ETC
T7      PERSON PERFORMING STUDY AND DATE ARE USEFUL INFORMATION
T8      AND COMPUTER FILE NAME.  THIS EXAMPLE IS NOT COMPLETE.  IT SHOWS RECORDS DOWN TO LQ-LT
I1      20          0          1          0          0          0
I2 CLAY  2          1          1          2.80        0.02          69          30.          16.
I2 CLAY  1          .02        .02          .02          100          0
I2 CLAY  2          .02        .02          .02          100          0
I3 SILT  2          1          4          2.80        0.02          69          65.          5.7
I4 Yang  4          1          15
I5      0          1          0          1          0          0          1          2
I6 MAXC  1          .301886   .301886   .150943
LQ DISCH 1          100        20000    100000
LT TOTAL 137786    137786    137786    137786
LF CLAY  .06          .06          .06          .06
LF SILT  .06          .06          .06          .06
    
```

Field	Variable	Value	Description
0	ICG,IDT	T4	Record identification in Columns 1 and 2. <b>T4, T5, T6, T7,</b> and <b>T8</b> for the first through fifth title records, respectively.
Column 4 of <b>T4</b> -Record only	ISI(2)	B	<b>Data Echo.</b> Each input record is echoed in the output file as it is read. This is available to help the user verify the initial conditions of the model and is not recommended for normal use. To exercise this option, enter B in Column 4 of the first title record ( <b>T4</b> ) of this group.
1-10		O	Turn off input data printout from sedimentary model.
			Fields 1 through 10 (Columns 5-80) may be used for identifying the stream segment, project date, or any other relevant information.

HEC-6 Input Description  
Sediment Properties and Transport Functions

**F-2 I1-Record - Sediment Properties (required)**

This record contains sediment properties for the job. See the T4-Record for a larger set of example records.

```

Example:           FIELDS
1234567 1234567 1234567 1234567 1234567 1234567 1234567 1234567 1234567 1234567
T8      AND COMPUTER FILE NAME.  THIS EXAMPLE IS NOT COMPLETE.  IT SHOWS RECORDS DOWN TO LQ-LT
I1      20      0      1      0      0      0
I2 CLAY      2      1      1      2.80  0.02      69      30.      16.
    
```

Field	Variable	Value	Description
0	ICG,IDT	II	Record identification.
1	ISI	Comment	Any alphanumeric characters or comments.
2	SPI <sup>12</sup>		<b>Specify iterations</b> of the Exner computations.
		b,0	The program assigns 20.
		+	Assign the desired number of iterations.
		-1	Program calculate the value.
			Note: The value of SPI computed by the program can become very large resulting in excessive computer time.
3	IBG		Bed Gradation Option. Instructs program to calculate gradation in surface layer based upon transport capacity. Not recommended in normal application.
		0	Program uses gradation on N-Records to calculate transport capacity.
		+3	Program calculates gradation of surface layer based on inflowing load and sediment transport theory. Iterative process performed in three iterations (i.e., IBG iterations).

---

<sup>12</sup> **Note:** SPI affects computation time. If the value is left blank, the program assigns 20. That is usually satisfactory, but if the BED CHANGE and/or SEDIMENT LOAD PASSING EACH CROSS SECTION oscillates from one time step to the next try increasing SPI to twenty, fifty, etc, until the bed change and sediment load values are essentially the same as those calculated with SPI set to -1. SPI is especially critical when some cross sections have a hard bottom.

HEC-6 Input Description  
Sediment Properties and Transport Functions

F-2 I1-Record - Continued

Field	Variable	Value	Description
4	MNQ		Number of Parallel Discharges. This option is <b>no longer permitted</b> .
		0	Program assigns one.
5	SPGF	+	Specific Gravity of Fluid. It is used with density and acceleration of gravity to calculate unit weight.
		0	Program assigns 1.0000 (fresh water at 39.2 degrees F).
6	ACGR	+	Acceleration Due to Gravity.
		0	Program assigns 32.174 ft/sec (standard at 45 degrees latitude, sea level).
7	NFALL		Fall Velocity Computation Method. Refer to Chapter 2, Section 2.3.6, in HEC-6 User's Manual for a discussion of the available methods.
		0	Program defaults to Method 2.
		1	Original Toffaleti fall velocities.
		2	Federal Interagency Sedimentation Project (FISP) method for computing fall velocities.
8	IBSHER		Bed Shear Stress Computation Method.
		0,1	Program calculates bed shear stress as $\gamma DS$ for clay/silt erosion and deposition.
		2	Program uses $U_*$ from smooth wall law velocity distribution to calculate bed shear stress for clay/silt erosion and deposition.

**F-3 I2-Record - Parameters Required for Clay Transport (optional)**

*WARNING: THIS PROGRAM WAS DESIGNED FOR NON-COHESIVE SEDIMENT TRANSPORT. SOME VERY LIMITED COHESIVE THEORY WAS ADDED FOR SPECIAL PURPOSES AS IT MIGHT RELATE TO NON-COHESIVE TRANSPORT. THIS CODE WAS NEVER INTENDED TO MODEL COHESIVE SEDIMENT TRANSPORT EXCLUSIVELY. HOWEVER IT HAS BEEN USED ON SOME SUCCESSFUL APPLICATIONS INVOLVING COHESIVE SEDIMENTS BY CAREFULLY POSING THE QUESTIONS AND CONFIRMING THE MODEL TO PROTOTYPE DATA.*

The presence of **I2**-Records instructs the program to include clay in the calculations. Always use method 2 and code the two **Special I2**-Records. The data included on these records provide coefficients for erosion, deposition and compaction of the clay deposit over time.

```

Example:           FIELDS
1234567 1234567 1234567 1234567 1234567 1234567 1234567 1234567 1234567 1234567
I1           20      0           1      0      0      0
I2 CLAY      2      1      1      2.80  0.02      69      30.      16.
I2 CLAY      1      .02      .02      .02      100      0
I2 CLAY      2      .02      .02      .02      100      0
I3 SILT      2      1      4      2.80  0.02      69      65.      5.7
    
```

A more complete sequence of records is shown at the T4-Record description. However, **do not** use the coefficients from these examples for a real problem.

Field	Variable	Value	Description
0	ICG,IDT	I2	Record identification.
1	ISI	Comment	Any alphanumeric characters or comments.
2	MTCL		Clay Transport Method.
		0,1	(The original method) Only Deposition is computed. No clay erosion is computed.
		2	Deposition and erosion of cohesive sediments are computed.
		<b>Note:</b>	<b>This method requires the addition of two Special I2-Records, as described in the following pages.</b>

**I2-Record - Parameters Required for Clay Transport (Continued)**

Field	Variable	Value	Description
3	ICS	b,1	Initial class size - i.e. first size class interval for clay. At present there is only one clay size available, so enter 1 or leave blank.
4	LCS	b,1	Last class size - i.e. final size class interval for clay. (SEE ICS) Enter 1 or leave blank.
5	SPGC	+ 0	Specific gravity of clay particles. The default is 2.65.
6	DTCL	+ 0	The shear threshold for clay deposition. This is the average bed shear stress in lbs/sq ft above which clay will not be deposited. This value is ignored when the Special I2-Records are used. The default is 0.02 lb/sq ft.
7			Leave blank.
8	PUCD	+ 0	The unit weight for fully compacted clay deposits, lb/cu ft. The default is 78 lb/cu ft.
9	UWCL	+ 0	The initial (before compaction) unit weight for clay deposits, lb/cu ft. The default is 30 lb/cu ft.
10	CCCD	+ 0	Compaction coefficient for clay deposits for the equation: where time is in years. See Chapter 2, Section 2.3.5.3, of HEC-6 User's MANUAL. The default is 16 lb/cu ft/yr.

**F-4 I2-Records(Continued) -Cohesive Sediment Transport Method 2: Supplemental Parameters (optional)**

The **Special I2**-Records are used to code the depositional and erosional shear stress thresholds for fine grained cohesive sediment (clay and silt) to be used by clay and silt transport Method 2 (MTCL - **I2.2**, MTSL -**I3.2**). Refer to Chapter 2, Section 2.3.9, of HEC-6 User's Manual. If used, two **Special I2**-Records must be employed (in addition to the **I2**-Record described earlier): one to describe the active layer and one to describe the inactive layer.

The erosion parameters defined on these **Special I2**-Records apply to silt as well as clay sediments. If erosion of silt sizes is desired then an **I3**-Record must follow the **I2**-Record.

Field	Variable	Value	Description
0	ICG,IDT	I2	Record identification.
1	ISI	Comment	Any alphanumeric characters or comments.
2	J	1	Data on this record applies to the active layer.
		2	Data on this record applies to the inactive layer.
3	DTCL	+	The shear threshold for clay and silt deposition. This is the average bed shear stress in lbs/sq ft above which clay and silt will not be deposited.
		0	The default is 0.02 lb/sq ft.
4	STCD	+	Shear stress threshold for erosion of clay and silt particles, lb/sq ft. This is the shear stress above which clay and silt material will be scoured from the bed. There is no default.
5	STME	+	Shear stress threshold for mass erosion, lb/sq feet. There is no default.
6	ERME	+	Erosion rate of clay and silt at STME, lb/sq ft/hr. There is no default.
7	ER2	+	Slope of the erosion rate curve for mass erosion, 1/hr. There is no default.
8	SLDTSL(J)	+	Enter the deposition threshold for Silt Particles if different from clay. J is the number of the layer type for this I2-Record.
		b	Program defaults silts to the clay deposition threshold bed shear stress

**I2-Record - Parameters Required for Clay Transport (Continued)**

Field	Variable	Value	Description
9	NFGSTY		If more than one set of erosion/deposition coefficients are needed to describe the characteristics of the Cohesive Sediment in this study area, enter the Coefficient TYPE Number in this field. The TYPE numbers are user assigned starting with 1. Up to 5 TYPES can be prescribed. Each Type requires two I2-Records: number one is for the active layer and number two is for the inactive layer.
		b	The default is 1. The program automatically assigns TYPE 1 to every cross section in the model. If only one set of Coefficients is used, that default is sufficient.
		1 - 5	Up to 5 sets of coefficients are permitted.
10	ASN(NXS)		If more than one type of cohesive sediment is coded, it is necessary to code where the coefficients apply. That can be done here for simple models. For stream networks it may require the IX-Record. (See the IX-Record in this data set.)  The Channel Station at the downstream end of the cohesive layer type coefficients in Field I2-8 on this record. Code the channel station where this TYPE number starts. It will be assigned to each cross section from there to the upstream end of this Segment.

**F-5 I3-Record - Parameters Required for Silt Transport (optional)**

The presence of an I3-Record instructs the program that the mixture of sediment to be analyzed contains silt size particles. The data included on this record provides parameters and guidelines within which to structure the computations for silt transport.

**NOTE: This model cannot transport SILT without CLAY.** The erosion of silts is based on the clay erosion parameters. If no clay is present in the inflowing water, enter zero for clay in the LF and [N, PF]-Records. There are no special or continuation I3-Records like there are above for clays. Silts use the values from the Clay records.

If sand transport is to be computed as well as silts, LASL should equal four. Grain sizes which are not found in the bed may be so noted with zero values in the bed material gradation specified on the [N, PF]-Records.

```

Example:           FIELDS
1234567 1234567 1234567 1234567 1234567 1234567 1234567 1234567 1234567 1234567
I2 CLAY      2      1      1      2.80  0.02      69      30.      16.
I2 CLAY      1      .02     .02     .02     100       0
I2 CLAY      2      .02     .02     .02     100       0
I3 SILT      2      1      4      2.80  0.02      69      65.      5.7
I4 Yang      4      1      15
    
```

Field	Variable	Value	Description
0	ICG,IDT	I3	Record identification.
1	ISI	Comment	Any alphanumeric characters or comments
2	MTSL		Silt Transport Method
		1	Original method for calculating deposition of silt.
		2	Method for including scour and deposition of silt.
			<b>Note:</b> Method 2 requires that Clay Transport also be Method 2 (I2-2). The two <b>Special I2-Records</b> will be required, as described previously.
3	IASL	+	ID number of the smallest grain size classification of silt to be transported (see Table A-2 below). IASL must always be less than LASL.
		0	Default IASL = 1.

F-5 I3-Record - Parameters Required for Silt Transport (Continued)

4	LASL	+	ID number of the largest grain size classification of silt to be transported .  0 Default
5	SGSL	+	Specific gravity of silt particles.  0 Default = 2.65
6	DTSL	+	Deposition threshold for silt. (NOTE: DTSL can be coded on the <b>Special I2-Records</b> , (I2-8).  The average bed shear stress in lb/sq ft above which silt material will not be deposited.  0 Default = 0.02 lb/sq ft (for lack of better data).
7			Leave blank.
8	PUSD	+	<b>Unit weight</b> of fully consolidated silt deposits in lb/cu ft.  0 Default = 85lb/cu ft.
9	UWSL	+	<b>Unit weight</b> of silt material at the moment it is deposited on the stream bed.  0 Default = 65 lb/cu feet.
10	CCSD	+	<b>Compaction coefficient</b> for silt deposits for the equation  where time is the accumulated simulation time expressed in years.  Default = 5.7 lb/cu ft/yr.

**Table A-2**  
**Grain Size Classes for Silt**

ID Number	Classification	Grain Size (mm)	Geometric Mean (mm)
1	Very Fine Silt	.004 - .008	0.0056
2	Fine Silt	.008 - .016	0.0113
3	Medium Silt	.016 - .032	0.0226

**IX**

HEC-6 Input Description  
Sediment Properties and Transport Functions

**IX**

**F-6 IX-Record - Cross Sections where Fine Sediment Coefficients Change (optional)**

The presence of an **IX**-Record allows the program to assign more than one set of sediment transport coefficients for clay and silt sediment.

Example:

```

                FIELDS
1234567 1234567 1234567 1234567 1234567 1234567 1234567 1234567
    
```

```

I3 SILT      2      1      4      2.80      0.02      69      65.      5.7
IX           1      1      1.0      5.50
IX           2      1      6.0      10
I4 Yang     4      1      15
I5          0      1      0      1      0      0      1      2
    
```

Field	Variable	Value	Description
0	ICG,IDT	I4	Record identification.
1	ISI	Comment	Any alpha-numeric characters or comments.
2	NFGSTY	1 Thru 5	The TYPE numbers are user assigned on I2-Records in this Sedimentary Data Set. <b>(SEE I2-Record in Sediment Data App.)</b> There is no default on this record.
3	NGDSL		Segment Number for Data on this Record.
4	ASN(NXSD)	-,+	The Channel Station at the downstream end of the reach where the cohesive layer type coefficients for the TYPE coded in IX-2 apply. It will be assigned to each cross section from there to the upstream end of this Segment.
		b	The program defaults to the Downstream End of the Reach.
	ASN(NXSU)	-,+	The Channel Station at the upstream end of the reach where these coefficient apply.
		b	The program defaults to the Upstream End of the Reach.

**F-7 I4-Record - Parameters Required for Sand Transport (optional)**

The presence of an I4-Record instructs the program that sand sizes are present in the mixture of sediment to be analyzed. The data included on this record provides parameters and guidelines within which to structure the computations for sand transportation. The following table of grain sizes is built into HEC-6. IASA and LASA must be selected from this table. All sizes between and including IASA and LASA will be transported.

**Table A-3  
Grain Size Classes for Sands and Larger**

ID Number	Classification	Grain Size (mm)	Geometric Mean (mm)
1	Very Fine Sand	.062 - .125	0.088
2	Fine Sand	.125 - .250	0.177
3	Medium Sand	.250 - .500	0.354
4	Coarse Sand	.500 - 1.0	0.707
5	Very Coarse Sand	1.0 - 2.0	1.414
6	Very Fine Gravel	2.0 - 4.0	2.828
7	Fine Gravel	4.0 - 8.0	5.657
8	Medium Gravel	8.0 - 16.0	11.314
9	Coarse Gravel	16.0 - 32.0	22.627
10	Very Coarse Gravel	32.0 - 64.0	45.255
11	Small Cobbles	64.0 - 128	90.50
12	Large Cobbles	128 -256	181.02
13	Small Boulders	256 - 512	362.04
14	Medium Boulders	512 - 1024	724.08
15	Large Boulders	1024 - 2048	1448.15

```

Example:           FIELDS
1234567 1234567 1234567 1234567 1234567 1234567 1234567 1234567 1234567 1234567
I3 SILT      2      1      4      2.80    0.02      69      65.      5.7
I4 Yang      4      1      15
I5           0      1      0      1      0      0      1      2
    
```

**I4-Record - Parameters Required for Sand Transport (Continued)**

Field	Variable	Value	Description
0	ICG, IDT	I4	Record identification.
1	ISI	Comment	Any alphanumeric characters or comments.
2	MTC <sup>13</sup>		Transport capacity relationship to be used by program to compute sediment load for a given water discharge.
		0,1	Toffaleti Method (1969).
		2	User Specified Transport Function. User must supply his own transport relationship in the form of DS versus transport coefficients (on records <b>J</b> and <b>K</b> ), where DS is depth times slope. See instructions for the <b>J</b> and <b>K</b> -Records for a more complete description.
		3	Madden's (1963) modification of Laursen's (1958) relationship.
		4	Yang's stream power (1973).
		5	Duboy's (Brown, 1950).
		6	Einstein.
		7	Ackers-White (1973).
		8	Colby (1964).
		9	Toffaleti and Schoklitsch combination.
		10	Meyer-Peter and Muller Gravel Transport (1948).
		11	Schoklitsch Gravel Transport
		12	Toffaleti (1969) - Meyer-Peter and Muller (1948) combination.
		13	Madden's (1985) modification of Laursen's (1958) relationship.
		14	Laursen-Copeland.
		15	Engelund-Hansen
		16	Parker Gravel Transport (1990)
		17	Not used at present.
		18	Profitt(Sutherland)

---

<sup>13</sup> Users should refer to Chapter 2 of the ASCE Manual 54, "Sedimentation Engineering" (1975), for information regarding the best transport function to use for specific types of rivers and bed material types.

**I4-Record - Parameters Required for Sand Transport (Continued)**

Field	Variable	Value	Description
		19	Brownlie (With Transport Normalized at D50 Value)
		20	Brownlie (With Transport Calculated for each Grain Size)
		21	Yang-High Concentration Formula, 1996
3	IASA	+	Grain Size Class number of the smallest grain size of sand to be transported in the calculations (see Table A-3). IASA must always be less than LASA.
		0	Default IASA = 1.
4	LASA	+	Grain Size Class number of the largest grain size of sand to be transported in the calculations (see Table A-3).
		0	Default LASA = 10.
5	SPGS	+	Specific gravity of sand particles. (Not the unit weight of deposited material.)
		0	Default = 2.65.
6	GSF	+	Grain shape factor.
		0	Default = 0.667.
7	BSAE	+	B coefficient in surface area exposed function. Equation is as follows:
			$FSAE = (1. - CSAE) * SAE^{BSAE} + CSAE$
		0	Default = 0.5.
8	PSI	+	The parameter $\psi$ from Einstein's method [29], used to approximate $\psi^*$ for calculating equilibrium bed elevation.
		0	Default = 30.
9	UWD	+	Unit weight of deposited sediment. Specify in lb/cu ft.
		0	Default UWD = 93 lb/cu ft, a reasonable value for sand. Program does not change this value with time.

HEC-6 Input Description  
Sediment Properties and Transport Functions

**F-8 I5-Record - Coefficients for Numerical Integration Method (optional)**

Use this record to enter the user selected hydraulic parameter integration coefficients. Chapter 2, Section 2.24 of the HEC-6 User's Manual presents two sets or schemes of weighing factors for the numerical integration method used by the program. If the I5-Record is omitted, the program defaults to the Scheme 2.

```

Example:           FIELDS
1234567 1234567 1234567 1234567 1234567 1234567 1234567 1234567 1234567 1234567
I4 Yang           4           1           15
I5                0           1           0           1           0           0           1           2
I6 MAXC          1 .301886 .301886 .150943
    
```

Field	Variable	Value	Description
0	ICG,IDT	I5	Record identification.
1	ISI	Comment	Any alphanumeric characters or comments.
2	DBI	+	Coefficient assigned to hydraulic properties at second cross section when calculating at downstream boundary.
3	DBN	+	Coefficient assigned to hydraulic properties at downstream boundary for downstream boundary calculations.
<b>Note:</b> If values are entered for DBI and DBN then DBI + DBN must equal 1.0.			
4	XID	+	Coefficient assigned to hydraulic properties at cross section downstream of section of interest - interior point calculations.
5	XIN	+	Coefficient assigned to hydraulic properties at cross section of interest - interior point calculations.
6	XIU	+	Coefficient assigned to hydraulic properties at cross section upstream of section of interest - interior point calculations.
<b>Note:</b> If values are entered for XID, XIN and XIU then XID + XIN + XIU must equal 1.0.			
7	UBI	+	Coefficient assigned to hydraulic properties at next to last cross section for calculation at upstream boundary.

HEC-6 Input Description  
Sediment Properties and Transport Functions

8	UBN	+	<p>Coefficient assigned to hydraulic properties at upstream boundary.</p> <p><b>Note:</b> If values are entered for UBI and UBN then UBI + UBN must equal 1.0.</p>
9	JSL	b,1,2	Numerical Options for Calculating Slope.
		b,1	The original HEC-6 option. The energy slopes on each side of the cross section are averaged.
		2	The $(Q/K)^2$ Slope at each cross section is weighted by the coefficients on this record.

**F-9 I6-Record - Concentrations for Flow Classification (optional)**

Use this record to change default values for the classification of Hyper-concentrated flow types. The default values are based on the classification proposed by the National research Council (1982).

```

Example:           FIELDS
1234567 1234567 1234567 1234567 1234567 1234567 1234567 1234567
I5           0           1           0           1           0           0           1           2
I6 MAXC      1 .301886 .301886 .150943
LQ DISCH     1           100       20000  100000
    
```

Field	Variable	Value	Description
0	ICG, IDT	I6	Record identification.
1	ISI	Comment	Any alphanumeric characters or comments.
2	LIDOPT		Option Number for Maximum permissible Concentration
		1	Version 4 Code: Original Method limited concentration of Cvmax and Cvud to 0.3 and Cvhyper to 0.15. To utilize option 1, code those values below.
		2	Version 5 Code: Program Defaults to this Option
3	CVMAX	+	Maximum Allowable Concentration (i.e. Transition to Landslide Event) of the water-sediment mixture by volume. [Cvmax = Cmg/SpGr Clay]
		b	Default is 0.5
4	CVMUD		Lower Limit of Mud Flow = Upper Limit of Hyper-concentrated flow. [Cvmud = Cmg/SpGr Clay]
		b	Default is 0.45
5	CVHYPER	+	Lower Limit of Hyper-concentrated flow = Upper Limit of water flood. [Cvhyper = Cmg/SpGr Clay]
		b	Default is 0.2
6	CURARE		A concentration to draw attention. (by volume) Reported at end of job in Summary Table
		b	Default is 0.0183 (50,000 mal)

$$GP_i = (((EFD * S$$

---

<sup>14</sup> If this special transport function option is selected, then a set of J-Records and a K-Record are required.

**J and K-Records - User Specified Transport Function (Continued)**

Use the **K** to define the coefficients of the function which is used to correct the User Specified Transport Function for variation in n-value.

$$STO = 1.E-6 * D * n^E$$

Field	Variable	Value	Description
0	ICG		Record identification (Column 1).
1	ISI	Comment	Comment information such as the name of the grain size classification to which the data on this record relates.
2	CNCO(1)		Coefficient corresponding to D in above equation.
3	CNCO(2)		Coefficient corresponding to E in above equation.

**LQ, LT**  
**LC, LF**

HEC-6 Input Description  
Sediment Properties and Transport Functions

**LQ, LT**  
**LC, LF**

**F-11 LQ-[LT, LC]-LF-Records - Sediment Inflow Boundary Condition (required)**

The inflowing sediment load is a boundary condition. A sediment load is needed for every water discharge in the inflowing hydrograph. However, rather than coding a sediment load for every water discharge, the inflowing sediment load is related to water discharge by a sediment discharge rating curve. That rating curve is then coded as a table having:

- (1) water discharge on the **LQ**-Record,
- (2) total sediment load in tons per day on the **LT**-Record, and
- (3) the fraction of the sediment load in each grain size class on **LF**-Records.

An alternative to the **LT**-Record is the **LC** in which total sediment inflow is prescribed in units of mg/l, and the sediment discharge is calculated with the following equation

$$QSED \text{ (tons/day)} = 0.0027 * QW(\text{cfs}) * CSED(\text{mal})$$

Example:                    FIELDS  
1234567 1234567 1234567 1234567 1234567 1234567 1234567 1234567 1234567 1234567  
CP            2  
LQ                    1        100        1000        10000        100000        840000  
**LT** **T/D**    .0027        0.81        48.6        10800        270000        6804000  
LF VFS            .80        .55        .40        .35        .40        .40  
LF FS             .15        .30        .40        .30        .30        .30  
LF MS             .04        .10        .10        .15        .15        .15  
LF CS             .01        .04        .06        .12        .10        .09  
LF VCS            .00        .01        .04        .08        .05        .06

or

Example:                    FIELDS  
1234567 1234567 1234567 1234567 1234567 1234567 1234567 1234567 1234567 1234567  
CP            2  
LQ                    1        100        1000        10000        100000        840000  
**LC** **mal**        1        3        18        400        1000        3000  
LF VFS            .80        .55        .40        .35        .40        .40  
LF FS             .15        .30        .40        .30        .30        .30  
LF MS             .04        .10        .10        .15        .15        .15  
LF CS             .01        .04        .06        .12        .10        .09  
LF VCS            .00        .01        .04        .08        .05        .06

**F-11.1 LQ-Record - Water Discharge for the Inflowing Sediment Load Relationship (required)**

**The Inflowing Sediment Load Relationship (Continued)**

Field	Variable	Value	Description
0	ICG, IDT	LQ	Record identification.
1	ISI	Comment	Any alphanumeric characters or comments.
2	QW(1)	+	Water discharge in cfs. Enter the first discharge value for the water discharge versus sediment load table. If the range of water discharges in the inflow hydrograph is beyond that specified in this table, the extreme values of sediment load from the table will be used (i.e. the program will not extrapolate beyond the ends of the table).
3	QW(2)	+	The second water discharge for the sediment load table. Each consecutive water discharge must be greater in value than the previous one.
4-10	QW(3) - QW(9)	+	Continue to enter increasing water discharge values W.r.e. d[(trem)89r[(a-R4404 lo

**LQ, LT**  
**LC, LF**

HEC-6 Input Description  
Sediment Properties and Transport Functions

**LQ, LT**  
**LC, LF**

**The Inflowing Sediment Load Relationship (Continued)**

3	QSED(2)	+,0	Total sediment load in tons per day. This value corresponds to the water discharge entered in Field 3 of the <b>LQ</b> -Record.
4-10	QSED(3)- QSED(9)	+,0	Continue to enter the total sediment load values for each subsequent water discharge entered on the <b>LQ</b> -Record. A maximum of nine values is permitted.

**The Inflowing Sediment Load Relationship (Continued)**

**F-11.3 LF-Record -Fraction of Inflowing Sediment Discharge in each grain size class (required)**

Each **LF**-Record will describe the sediment load of one grain size fraction. There must be one **LF**-Record for each grain size classification selected on records **I2** through **I4** even if the fraction of the load for any grain size equals zero. **LF**-Records should be entered from fine to coarse.

Field	Variable	Value	Description
0	ICG, IDT	LF	Record identification.
1	ISI	Comment	Any alphanumeric characters or comments. (It is recommended that the grain size class be entered in the comment field, i.e. CLAY, SILT1, SILT2, VFS, FS,...VCG.)
2	QSF	0. to 1.0	The fraction for this grain size of the total sediment load corresponding to the water discharge in Field 2 of the <b>LQ</b> -Record.
3	QSF	0. to 1.0	The fraction for this grain size of the total sediment load corresponding to the water discharge in Field 3 of the <b>LQ</b> -Record.
4-10	QSF	0. to 1.0	Continue to enter the fraction of the total sediment load corresponding to each subsequent water discharge entered on the <b>LQ</b> -Record. A maximum of nine values if permitted.

**F-12 LQ-SD-Records - Sediment Distribution Coefficients at a Junction**

The sediment discharge entering a distributary can be regulated by prescribing a table of Sediment Distribution Coefficients. That table has a form similar to the sediment inflowing load table. It uses the LQ-Record to prescribe water discharge but, rather than LT-LF-Records, the sediment distribution table expects a SD-Record for each grain size class which contains the sediment distribution coefficients. The program calculates the sediment distribution with the following equation

$$QSED \text{ (tons/day)} = 0.0027 * QW(\text{cfs}) * CSED(\text{mg/l}) * SDCOEF$$

The program calculates QW using the Closed Loop Function, and it calculates CSED by calculating the sediment discharge entering the junction. It interpolates from the LQ-SD table to get the distribution coefficient, SDCOEF.

Use only 1 distribution table at the same junction because only one of the distributary segments can be regulated. The other must be free to convey the remaining sediment out of the junction.

Example:            FIELDS

1234567	1234567	1234567	1234567	1234567	1234567	1234567	1234567	1234567	1234567
CP	2								
LQ		1	100	1000	840000				
SD	VFS	.8	.55	.40	.40				
SD	FS	.8	.30	.40	.30				
SD	MS	.4	.10	.10	.15				
SD	CS	.1	.04	.06	.09				
SD	VCS	00	.01	.04	.06				

**F-12.1 LQ-Record - Water Discharge for Sediment Distribution Coefficients at a Junction**

Same as above for the sediment load boundary condition

**Sediment Distribution Coefficients at a Junction (Continued)****F-12.2 SD-Record - Sediment Distribution Coefficient at a Junction**

Each **SD-Record** will contain the table of sediment distribution coefficients for one grain size fraction. There must be one **SD-Record** for each grain size class selected on records **I2** through **I4** - even if the fraction is zero (i.e. same number as there are **LF-Records**). Enter **SD-Records** in the sequence of **smallest to largest** grain size class (i.e. same as the **LF-Records** above).

Field	Variable	Value	Description
0	ICG,IDT	SD	Record identification.
1	ISI	Comment	Any alphanumeric characters or comments. (It is recommended that the grain size class be entered in the comment field, i.e. CLAY, SILT1, SILT2, VFS, FS,...VCG.)
2	SDCOEF	0. to 1.0	The fraction of the sediment concentration which will pass into this branch of the model for this grain size class. The value corresponds to the water discharge in Field 2 on the <b>LQ-Record</b> with this sediment distribution coefficient data.
3	SDCOEF	0. to 1.0	The distribution coefficient corresponding to the water discharge in Field 3 of the <b>LQ-Record</b> .
4-10	SDCOEF	0. to 1.0	Continue to enter the distribution coefficients corresponding to each subsequent water discharge on the <b>LQ-Record</b> . A maximum of nine values if permitted.

HEC-6 Input Description  
Sediment Properties and Transport Functions

**F-13 N-Record - Bed Material Gradation**

Note: The PF-RECORD was created to replace the N-Record. Use the PF for ease of coding bed gradation data. However, the \$TAPE12 Option uses N-Records; and N-Records cannot be mixed with PF-Records on the same data Segment of a model.

The initial **Bed Material Gradation** must be prescribed for each cross section in the model. The number of size classes is the sum of the number of grain sizes prescribed on the **I2 plus I3 plus I4**-Records. Enter data for each cross section even if the bed material gradation does not change between cross sections. Code from the downstream to the upstream direction. The fractions should sum to 1.0 at a cross section.

For example, if there are 60 cross sections, with one clay, four silts and four sands defined on the **I2 - I4**-Records (e.g., nine different size classifications), 120 N-Records will be required. Four grain sizes will fit on the first N-Record, and the remaining 5 will fit on the second N-Record as shown in the following example.

Example:        FIELDS  
 1234567 1234567 1234567 1234567 1234567 1234567 1234567 1234567 1234567  
 N 15.08            .00656   .00328       .90            .001    .001    .001    .002  
 N            .003    .005       .45       .37       .167

Field	Variable	Value	Description
0	ICG	N	Record identification (Column 1).
1	ISI	Comment	Comment field (recommend cross section ID number always to be used here).
2	SAE		The fraction of surface area of the bed that is not covered by armor layer at this cross section. Divide the surface area exposed to scour by the total surface area to obtain this value. this parameter is used to describe initial bed armoring conditions.
		Blank	Program uses 1.0 for initial value.
		.001-1.0	Program uses the value entered as the initial value rather than 1.0.

HEC-6 Input Description  
Sediment Properties and Transport Functions

**F-13 N-Record - Bed Material Gradation (Continued)**

Field	Variable	Value	Description
3	DMAX		Maximum grain size at this cross section. Obtain from the gradation curve the diameter for which 100 percent is finer.
		+	Enter grain size in feet.
		0	Program uses the diameter of the largest grain size defined on the <b>I2 - I4</b> -Records.
4	DXPI		Grain size in 80 to 95 percent finer range.
		+	Enter grain size in feet that is approximately 95 percent size on gradation curve. It should define the upper breakpoint in the gradation curve. Must be less than or equal to DMAX (N.3).
		0	Program uses DMAX (N.3).
5	XPI		Percent finer for DXPI (N.4) expressed as a decimal.
		+	Range is from 0 to 1.00.
6	SFITOT	+	Total of grain size fractions in the bed at this particular cross section. <b>(No longer used - leave blank.)</b>
7	SFIL(1)	.001-1.0	Program sums all values that follow for individual grain sizes. The fraction of the total amount of bed material composing the smallest size classification present in the bed at this particular cross section.
		0	Code a value for each grain size. If a grain size is not present at this cross section then enter zero.
8-10	SFIL(2)		If more than one grain size is present in the bed, enter fractions across this-Record, from finest to coarsest, for each size classification. Continue in Field 2 of a second N-Record if needed.

**F-14 PF-Record - Bed Material Gradation**

The **PF-Record** is an alternative to **N-Records** for prescribing the gradation of the bed sediment reservoir. They utilize the percent finer curve. The sediment computations require the bed material gradation at each cross section; however, it is not necessary to enter a **PF-Record** set for every cross section in the network. The program uses the following rules to fill in for missing **PF-Records**. An example is shown on the next page.

- a. There must be at least one **PF-Record** for each stream segment in the network. If only one **PF-Record** is present, that gradation is used for all cross sections on that stream segment.
- b. The cross section ID number (i.e. river mile) is coded in Field 2 and read by the program. That ID number should correspond to one used previously on an **X1-Record**. If more than one **PF-Record** is present, but not one for each cross section on the stream segment, linear interpolation is used to fill in the missing data.
- c. If the cross section ID number is omitted from a **PF-Record**, it will be assigned to the last cross section (i.e. the one most upstream), and values to the previous **PF-Record** will be interpolated.
- d. The gradation for any cross sections before the first or after the final **PF-Records** are assigned the values on those-Records.
- e. Do not skip grain sizes on the **I2, I3, and I4-Records** {i.e. When clay and silt are present, set **IASL** and **LASL** for 1 and 4, (**I3-3 and I3-4**) and set **IGS** = 1, (**I4-3**.) It is not necessary to calculate all 20 size classes.
- f. It is not necessary that a **PF-coordinate** correspond to a grain size class interval boundary, but it can. Semi-log interpolation is used to calculate the percent finer at each class interval boundary, and these are subtracted to calculate the fraction of sediment in each size class. Therefore, use **DAXIS** = .001 for the smallest size -- not **DAXIS** = 0.

```

Example:           FIELDS
1234567 1234567 1234567 1234567 1234567 1234567 1234567 1234567 1234567
PF      15.08           2       1       90       .5       45       .1       1
PFC .001           0
    
```

Field	Variable	Value	Description
0	ICG,IDT	PF	Record identification.
		PFC	Record identification, continuation-Records.
1	ISI	Comment	Comment on <b>PF</b> -Record; data on <b>PFC</b> -Records.
2	SECID	-,0,+	Cross section ID number (i.e. river mile). There is not default. Do not leave this field blank.
3	SAE	b,0	The fraction of the bed surface that is exposed to erosion. That is, a portion of the bed may be armored or partially covered with bedrock. Usually SAE is left blank in which case the program will default to 1.0.
		.001-1.0	The normal range.
4	DMAX	+	The diameter of the maximum particle size. Code all diameters in millimeters. <sup>15</sup> Always code a value. The program assigns a percent finer (PFXIS(1)=100) to correspond with DMAX. DMAX should be equal to the largest size being transported (I4-4). DMAX is also known as DAXIS(1).
5	DAXIS(2)	+	The grain size diameter at the first coordinate point down the percent finer curve from DMAX. If this particle size is larger than 64 mm, choose a point that will approximate the PF-Curve with two straight line segments from DMAX to 64 mm.
6	PFAXIS(2)	0,+	The percent finer corresponding to DAXIS(2). Code as a percent (e.g., enter 10 for 10 percent, 20 for 20 percent, etc.).
7-10	DAXIS- PFAXIS	0,+	Continue to code points from the percent finer curve in (grain size diameter, percent finer) pairs. Use up to three continuation <b>PFC</b> -Records to code a maximum of twenty points. Begin coding data in Field 1 on continuation-Records.

**OF**

HEC-6 Input Description  
Sediment Properties and Transport Functions

**OF**

**F-15      OF-Record - Active Layer Gradation (Optional)**

---

4 Millimeters and percent finer are required by the **PF**-Records rather than feet and fraction as required by the **N**-Records.

Use OF-Records only when it is necessary to prescribe the Active Layer. Normally the computer program calculates the Active Layer using the PF-Records and hydraulic parameters for the first water discharge event. When this-Record is used, it must be present for each cross section in the network.

Example:        FIELDS  
 1234567 1234567 1234567 1234567 1234567 1234567 1234567 1234567 1234567 1234567  
 OF        86.00        .25        93        0        0        0        1

Field	Variable	Value	Description
0		OF	Code RECORD Identifier in Col 1-2
		OFC	Continue Coding OF-Data
1	CMT		Comment in Columns 2-8
2	AVGS	-,b,+	Cross Section River Mile Corresponding to X1-1
3	DAL	b,+	Depth of Active Layer, Feet
4	AUWAL	+	Average Unit Weight of the Active Layer, pounds/cuft
5	FRAC(1)	0 to 1.	Fraction of the Smallest Size Class in this data set.
6	FRAC(2)	0 to 1.	Fraction of next larger size class in this data set.
7	FRAC(3)	"	Fraction of 3rd size class ...
10	FRAC(6)		...
	FRAC(7)	"	Continue Coding on a OFC-Record beginning in Field 1 with FRAC(7). The FRAC(i) values should sum to 1.0

**\$LOCAL**  
**LQL, LCL**  
**LTL, LFL**

HEC-6 Input Description  
Sediment Properties and Transport Functions

**\$LOCAL**  
**LQL, LCL**  
**LTL, LFL**

**F-16      \$LOCAL Option - Local Inflow and/or Outflow Points**

This-Record set is a water-sediment discharge rating table for local inflows and/or outflows. When a segment has a local inflow/outflow point, place the **\$LOCAL** command after the **PF** (or **N**)-Records for that segment. Follow that command with the inflow/outflow table.

The inflow/outflow table consists of water discharges and sediment concentration information. The water discharges are coded on the **LQL**-Record. The total inflowing sediment load is coded on the **LTL**-Record in units of tons/day. [An alternative for coding the sediment inflow is to use the **LCL**-Record.] The fraction of the total sediment inflow which is in each grain size class is coded on **LFL-Records**. Sediment outflows are not coded in tons/day. Those values will not be known. Code a fraction, from zero to 1, of the ambient concentration and the model will calculate the sediment outflow based on the water outflow.

Use only one **\$LOCAL** command per segment even though several inflow/diversion points may exist on a stream segment. Place the local inflow/outflow tables in sequence counting from the downstream end of the segment. Each inflow/outflow point prescribed by a **QT** or **QP**-Record needs a Local inflow/outflow table.

Enter one **LFL**-Record for each size class which has been requested on the **I2, I3 and I4**-Records. The **LFL**-Records should be placed in the data file from fine to coarse. That is, the first should be Clay if clay is present in the model, and the last should be Large Boulders if large boulders are present in the model. The fractions on these **LFL**-Records should sum to 1.00.

Examples of these data sets are shown for three cases:

1. A local where all flows are inflows;
2. A local where all flows are outflows (i.e. ...diversions);
3. A local where flows are mixed between inflows and outflows.

Each case uses the same-Record types. They differ in coding requirements as explained below.

**\$LOCAL  
LQL, LCL  
LTL, LFL**

HEC-6 Input Description  
Sediment Properties and Transport Functions

**\$LOCAL  
LQL, LCL  
LTL, LFL**

**F-16.1 \$LOCAL-Record**

**Note:** The \$LOCAL-Record replaces the \$TRIB-Record in 1975 Version Data Sets.

Field	Variable	Value	Description
0	ICG, IDT	\$LOCAL	Record identification (Columns 1 through 6).

**F-16.2 Case 1: LQL-[LTL, LCL]-LFL The Local entry point is only inflows (i.e. no diversions are present.)**

The following example is Case 1: Two local inflow points. All flows are inflows. It shows six water discharges for Local #1, but usually fewer than six are adequate to describe the sediment inflow rating curve. If more than 1 local inflow point is present, use only 1 \$LOCAL command. The number of water discharges can be different for each local inflow table. However, except for special occasions, the LQL-Record should contain at least two water discharge values.

```

Example:           FIELDS
1234567 1234567 1234567 1234567 1234567 1234567 1234567 1234567 1234567 1234567
$LOCAL
LQL #1           1      100    1000   10000  100000  840000
LTL T/D          .1      1      50     4000  200000 1450000
LFL VFS          .80     .55    .40    .35    .40     .40
LFL FS           .15     .30    .40    .30    .30     .30
LFL MS           .04     .10    .10    .15    .15     .15
LFL CS           .01     .04    .06    .12    .10     .09
LFL VCS          .00     .01    .04    .08    .05     .06
LQL #2           1      100    1000   40000
LTL T/D          .1      20     500   500000
LFL VFS          .80     .40    .35    .40
LFL FS           .15     .40    .30    .30
LFL MS           .04     .10    .15    .15
LFL CS           .01     .06    .12    .09
LFL VCS          .00     .04    .08    .06
  
```

The LQL, [LTL, LCL] and LFL-Records for this option are described in the next three tables.

**LQL-Record - Water Discharge for a Local Inflow**

**\$LOCAL  
LQL, LCL  
LTL, LFL**

HEC-6 Input Description  
Sediment Properties and Transport Functions

**\$LOCAL  
LQL, LCL  
LTL, LFL**

Field	Variable	Value	Description
0	ICG,IDT	LQL	Record identification (Columns 1 through 3).
1	ISI	Comment	Any alphanumeric character comment.
2	QWL(1)	+	Water Discharge, cfs - Enter a positive discharge whose absolute value is smaller than the smallest inflow value in the local inflow hydrograph for this local.
3	QWL(2)	+	Water Discharge - Enter discharges in increasing order as necessary to approximate the water-sediment discharge rating as plotted on log-log paper. The program will interpolate between the water discharge values using log-log interpolation.
4	QWL(3)	+	Continue entering water discharges
5	QWL(4)	+	
6-10	QWL(5-9)	+	... up to nine discharges are permitted. Enter in increasing order of magnitude. No inflow discharge in the local inflow hydrograph for this entry point should be larger than the largest QWL in this table.

No continuation-Record is permitted.

**LTL-Record - Total Sediment Load for a Local Inflow**

Field	Variable	Value	Description
0	ICG,IDT	LTL LCL	Record identification (Columns 1 through 3).
1	ISI	Comment	Any Alphanumeric Characters or comments.
2	QSED(1)	+	Total sediment load in tons/day if LTL-Record, or Total sediment concentration in mgl if LCL-Record. This is the sediment value corresponding to water discharge QWL <sub>1</sub> on the previous LQL-Record.
3	QSED(2)	+	Ditto for the second QWL
4	QSED(3)	+	Entering the sediment discharge for each water discharge on the previous LQL-Record.

**\$LOCAL  
LQL, LCL  
LTL, LFL**

HEC-6 Input Description  
Sediment Properties and Transport Functions

**\$LOCAL  
LQL, LCL  
LTL, LFL**

Field	Variable	Value	Description
5	QSED(4)	+	
6-10	QSED(5-9)	+	No continuation-Record is permitted.

**LFL-Record - Fraction of each size class in the Local Inflow**

The LFL-Records contains the fraction of the total sediment inflow which is in each grain size class. Therefore, enter one **LFL**-Record for each size classes which has been specified on the **I2, I3 and I4**-Records. The **LFL**-Records should be placed in the data file from fine to coarse. That is, the first should be Clay if clay is present in the model, and the last should be Large Boulders if large boulders are present in the model.

Field	Variable	Value	Description
0	ICG,IDT	LFL	Record identification (Columns 1 through 3).
1	ISI	Comment	Any alphanumeric character comment. (It is recommended that the grain size class be entered in the comment field, i.e. CLAY, SILT1, SILT2, VFS, FS, ... VCG).
2	FSC(1)	0 to 1.0	Enter the fraction of QSED(1) which is in this sediment size class. SEE LTL, LCL and LQL-Records.
3	FSC(2)	0 to 1.0	Enter the fraction of QSED(2) which is in this sediment size class.
4 - 10	FSC(3) to FSC(9)	0 to 1.0	Enter a value for each QSED(...).

**\$LOCAL  
LQL, LCL  
LTL, LFL**

HEC-6 Input Description  
Sediment Properties and Transport Functions

**\$LOCAL  
LQL, LCL  
LTL, LFL**

**F-16.3 Case 2: LQL-LTL-LFL The Local Inflow/Outflow Point Contains only Outflows (i.e. diversions).**

The following example is Case 2: All flows are outflows (diversions). It shows two water discharges and that is usually adequate to describe the diversion coefficients.

```
Example:          FIELDS
1234567 1234567 1234567 1234567 1234567 1234567 1234567 1234567 1234567 1234567
$LOCAL
LQL      -100000      -1
LTL              1      1
LFL VFS              1      1
LFL FS              1      1
LFL MS              1      1
LFL CS              1      1
LFL VCS              1      1
```

Diversion tables look like inflowing load tables; however it is not possible to prescribe the sediment concentrations in the outflow because those concentrations depend on how much sediment is moving, and that is what the program calculates. Therefore, coefficients, COEF(i), which relate the concentration in the outflow to the approaching sediment concentration in the main channel are coded on the LFL-Records. A COEF(i) is required for each grain size class. The program will multiply these COEF values times the approaching concentrations (called the ambient concentrations) to determine how much of that concentration to include in the water outflow. The following equation is used.

$$QSO(i) = 0.0027 * COEF(i) * C(i)_{Ambient} * QWO$$

where:

- C(i) = The approaching sediment concentration for size class i  
(Calculated by program)
- COEF(i) =  $\{C_{Diverted}/C_{Ambient}\}$  for size class i
- QSO(i) = Sediment discharge diverted out of channel
- QWO = Water discharge diverted out of channel

Since the diverted concentration may change with flow in the river, a table of coefficients is coded using the LQL-Record to vary water discharge. Also, a coefficient is required for each grain size class. That is, if

**\$LOCAL  
LQL, LCL  
LTL, LFL**

HEC-6 Input Description  
Sediment Properties and Transport Functions

**\$LOCAL  
LQL, LCL  
LTL, LFL**

a COEF(VCS) is 0.0, the approaching concentration for VCS (Very Coarse Sand) will be multiplied by 0 to determine how much very coarse sand to include in the diverted water discharge. The COEF values are coded on LFL-Records.

The LQL, LTL and LFL-Records for this option are described in the next three tables. **NOTE: Do not use the LCL-Record for CASE 2.**

**LQL-Record - Water Discharge for a Local Outflows**

Field	Variable	Value	Description
0	ICG, IDT	LQL	Record identification (Columns 1 through 3).
1	ISI	Comment	Any alphanumeric character comment.
2	QWL(1)	-	Water Discharge - Enter a negative number whose absolute value is larger than the largest outflow in the hydrograph. For example, if the maximum diversion value was -100000, then enter -100001.
3	QWL(2)	-	Enter a non-zero number whose absolute value is less than the smallest outflow in the hydrograph. For example, if the minimum diversion value is -1, enter -0.9. At least two QWL values are recommended. All water discharges in the outflow hydrograph should fall between these two values.
4-10			It is permissible to enter up to nine QWL.

**\$LOCAL  
LQL, LCL  
LTL, LFL**

HEC-6 Input Description  
Sediment Properties and Transport Functions

**\$LOCAL  
LQL, LCL  
LTL, LFL**

**LTL-Record - Water Discharge for a Local Outflows**  
(Note: Do not use LCL-Records for Case 2)

Field	Variable	Value	Description
0	ICG,IDT	LTL	Record identification (Columns 1 through 3).
1	ISI	Comment	Any Alphanumeric Characters or comments.
2	QSED(1)	1.0	This value should be 1.0
3 - 10	QSED(2) to QSED(9)	1.0	Enter a 1.0 corresponding to $QWL_2$ $QWL_9$ , respectively, on the previous LQL-Record.

**LFL-Record - Sediment Diversion Coefficient for Local Outflows**

Field	Variable	Value	Description
0	ICG,IDT	LFL	Record identification (Columns 1 through 3).
1	ISI	Comment	Any alphanumeric character comment. (It is recommended that the grain size class be entered in the comment field, i.e. CLAY, SILT1, SILT2, VFS, FS, ... VCG).
2	COEF(1)	0 to 1.0	Enter the fraction of the approaching concentration to assign to the water outflow, QWO
3	COEF(2)	0 to 1.0	Enter the fraction of the approaching concentration to assign to $QWL_2$
4-10	COEF(3) to COEF()		Usually there is not enough data to require more than 2 values. However, up to 9 values can be prescribed.

**\$LOCAL  
LQL, LCL  
LTL, LFL**

HEC-6 Input Description  
Sediment Properties and Transport Functions

**\$LOCAL  
LQL, LCL  
LTL, LFL**

**F-16.4 Case 3: LQL-[LTL, LCL]-LFL Combined Diversions and Inflows**

The following is an example data set for Case 3: Combined inflow and outflow at the same local entry point.

Example:                      FIELDS

	1234567	1234567	1234567	1234567	1234567	1234567	1234567	1234567	1234567
\$LOCAL									
LQL	-100000	-1	1	100	1000	10000	100000	840000	
LTL T/D	1	1	.1	1	50	4000	200000	1450000	
LFL VFS	1	1	.80	.55	.40	.35	.40	.40	
LFL FS	1	1	.15	.30	.40	.30	.30	.30	
LFL MS	1	1	.04	.10	.10	.15	.15	.15	
LFL CS	1	1	.01	.04	.06	.12	.10	.09	
LFL VCS	1	1	.00	.01	.04	.08	.05	.06	

**LQL-Record - Water Discharge for the Local Inflow/Outflow Table (optional)**

Field	Variable	Value	Description
0	ICG, IDT	LQL	Record identification (Columns 1 through 3).
1	ISI	Comment	Any alphanumeric character comment.
2	QWL(1)	-	Water Discharge, cfs - Enter a negative discharge whose absolute value is larger than the largest outflow value in the local inflow/outflow hydrograph for this local.
3	QWL(2)	-	Water Discharge - Enter a negative discharge whose absolute value is smaller than the smallest outflow value in the local inflow/outflow hydrograph for this local.
4	QWL(3)		Water Discharge - Enter a positive discharge whose absolute value is smaller than the smallest inflow value in the local hydrograph.
5	QWL(4)	+	The second Water Discharge in the inflow/diversion table.
6-10	QWL(5-9)	+	Enter up to nine discharges, in increasing order of magnitude, in fields 3 - 10. No inflow discharge in the local inflow hydrograph should be larger than the largest QWL.

No continuation-Record is permitted.

**[LTL, LCL]-Record - Diversion Coefficient for Local Outflows plus Inflowing Sediment Discharge or**

**\$LOCAL  
LQL, LCL  
LTL, LFL**

HEC-6 Input Description  
Sediment Properties and Transport Functions

**\$LOCAL  
LQL, LCL  
LTL, LFL**

**Concentration for Local Inflows**

Field	Variable	Value	Description
0	ICG,IDT	LTL, LCL	Record identification (Columns 1 through 3).
1	ISI	Comment	Any Alphanumeric Characters or comments.
2	QSED(1)	1.0	This value should be 1.0
3	QSED(2)	1.0	Enter a 1.0 corresponding to $QWL_3$ on the previous <b>LQL</b> -Record.
4	QSED(3)	+	Total sediment load in tons/day, or mg/l if LCL-Record, corresponding to the $QWL_4$ on the previous <b>LQL</b> -Record.
5 - 10	QSED(4-9)	+	Total sediment load corresponding to each additional water discharge coded on the previous <b>LQL</b> -Record. A maximum of seven values is permitted.

**LFL-Record - Diversion Coefficient for Local Outflows (i.e. Diversions)**

Field	Variable	Value	Description
0	ICG,IDT	LFL	Record identification (Columns 1 through 3).
1	ISI	Comment	Any alphanumeric character comment.
2	COEF(1)	0 to 1.0	Enter the fraction of the approaching concentration to assign to the water discharge, $QWL_1$ on the <b>LQL</b> -Record.
3	COEF(2)	0 to 1.0	Enter the fraction of the approaching concentration to assign to $QWL_2$ specified on the <b>LQL</b> -Record.
4	FSC(1)		Enter the fraction of the total sediment load for this size class corresponding to $QWL_3$ on the <b>LQL</b> -Record.
5	FSC(2)		Enter the fraction of the total sediment load for this size class corresponding to $QWL_4$ specified on the <b>LQL</b> -Record.
6-10	FSC(3) to FSC(9)	+,0	Enter one value for each water discharge specified on the <b>LQL</b> -Record. Up to 9 are permitted

**\$LOCAL  
LQL, LCL  
LTL, LFL**

HEC-6 Input Description  
Sediment Properties and Transport Functions

**\$LOCAL  
LQL, LCL  
LTL, LFL**

**F-16.5 Case 4: LQL-LTL-LFL-Records when using QL-Records**

One of the local inflow options is a "return flow" option. It is invoked with a QL-Record which links that return flow point with some outflow point in the network. (See instructions for Geometric and Channel Properties in Appendix E). The QL-Record provides 3 options for prescribing the amount of sediment in the returning water. One of those options is described here as Case 4. It will multiply the returning sediment by the fraction coded on the LFL-Records. The following is an example data set for Case 4.

```
Example:          FIELDS
1234567 1234567 1234567 1234567 1234567 1234567 1234567 1234567 1234567 1234567
T4      EX. NO. 40.  SEDIMENT DATA FOR QL-RECORD TEST          SEGMENT 1/3
T5      BED GRADATION ARE HYPOTHETICAL
T6      SEDIMENT INFLOW IS HYPOTHETICAL
T7
T8
I1          10
I4          14          1          2
PF          10          1.0  128.0   64.0   36.0   32.0   31.0   16.0   28.0
PFC 8.0    27.0    4.0    25.0    2.0    24.0    1.0    19.0    .50    16.0
PFC .250   15.0    .125   13.0
$LOCAL
LQL 3,1    .0001   40000
LTL          1          1
LFL          1          1
LFL          0          0
```

**LQL-Record - Water Discharge for the Local Inflow Table**

Field	Variable	Value	Description
0	ICG,IDT	LQL	Record identification (Columns 1 through 3).
1	ISI	Comment	Any alphanumeric character comment.
2	QWL(1)	+	Water Discharge - Enter a positive discharge whose absolute value is smaller than the smallest inflow value in the local hydrograph.
3	QWL(2)	+	The second Water Discharge in the inflow/diversion table.
4-10	QWL(3-9)	+	Enter up to nine discharges, in increasing order of magnitude. No inflow discharge in the local inflow hydrograph should be larger than the largest QWL in this table. No continuation-Record is permitted.

**\$LOCAL  
LQL, LCL  
LTL, LFL**

HEC-6 Input Description  
Sediment Properties and Transport Functions

**\$LOCAL  
LQL, LCL  
LTL, LFL**

**LTL-Record - Total Inflowing Sediment Discharge Coefficient**

Note: The LCL option is not available for the Case.

Field	Variable	Value	Description
0	ICG,IDT	LTL, LCL	Record identification (Columns 1 through 3).
1	ISI	Comment	Any Alphanumeric Characters or comments.
2	QSED(1)	1.0	This value should be 1.0
3	QSED(2)	1.0	Enter a 1.0 for $QWL_2$ on the previous <b>LQL</b> -Record.
...			
4 - 10	QSED(3-9)	1.0	Complete by entering a 1 under each water discharge coded on the previous <b>LQL</b> -Record. A maximum of nine QSED values are permitted.

No continuation-Record is permitted.

**LFL-Record - 2 0 0 12 298perms Giz Class.]TJ/TT1 1 Tf0.0002 Tc 0 Tw 1.1386 -43.494Td[(Field)-3933(Variable)-4014(Value)-1**

## **APPENDIX G**

### **INPUT DESCRIPTION FOR HYDROLOGIC DATA**



**\$HYD**

HEC-6 Input Description  
Hydrologic Data

**\$HYD**

**INPUT DESCRIPTION FOR HYDROLOGIC DATA**

**G-1      \$HYD-Record - Hydrologic Model (required)**

The **\$HYD**-Record marks the beginning of the hydrologic data. This-Record is required to precede discharge data-Records described on the following pages.

Field	Variable	Value	Description
0	ICG,IDT	\$HYD	Record identification (Columns 1 through 3).

\*

## HEC-6 Input Description Hydrologic Data

\*

### G-2      \*-Record - Comment and Print Control (required)

One comment-Record is required for each Q-Record in the hydrologic data. This-Record provides title information for each time step defined in the hydrologic data. It also allows the user to specify various output printing options.

```

Example:           FIELDS
1234567 1234567 1234567 1234567 1234567 1234567 1234567 1234567 1234567
*   B A EVENT 0 .. CONDITION THE NETWORK
Q   -1      -2      -3  350000
R   .6
T                               40
W   .1

```

Field	Variable	Value	Description
0	ICG	*	Record identification (Column 1).
<b>Column 5</b>	CLINE		Select printout from the hydrau

\*

HEC-6 Input Description  
Hydrologic Data

\*

\*-Record (continued)

Field	Variable	Value	Description
<b>Column 6</b>	CLINE		Select printout from sediment transportation computations.
		blank	No printout except summary at end of job. For this option leave Column 6 blank, not zero.
		A	A table showing the volume of sediment entering and leaving each segment and the computed trap efficiency for each segment.
		B	In addition to A, the bed change from the initial elevation in feet, water surface elevation in feet, bed thalweg elevation in feet, sediment load passing in tons/day for clay, silt and sand. This and all higher level selections cause a "solution file" to be written at this time step for post-processing purposes.
		C	A detailed printout of calculations (in addition to the above).
		D	In addition to the above values from Toffaleti's procedure showing the detailed distribution by grain size fraction for the bed surface material at each cross section before the values are corrected by percentage present in the bed. (Not recommended for normal applications.)
		E	Detailed trace for debugging purposes in addition to the above. (Not recommended for normal applications.)
2-10	Comment		Comment data for discharge-elevation-duration data that follows. Use the remainder of this-Record to provide title/comment information for this time step. This data will appear in the output

**Note:** Printout levels D and E produce a very large amount of output. This output was designed primarily for debugging purposes. Execution time will increase if any of these options are used.

\*

HEC-6 Input Description  
Hydrologic Data

\*

\*-Record (continued)

Field	Variable	Value	Description
Column 8	CLINE		Select printout from Closed Loop Calculations.
		blank	No printout.
		A	A-Level Print out provides a table of Final Flows for this event.
		B	Flows in each segment and discharge error at convergence.
		C	Conveyance data and detailed printout of Flow Distribution Calculations. (Excessive printout - use only for Program Debugging)

Q

## HEC-6 Input Description Hydrologic Data

Q

### G-3 Q-Record - Water Discharge Entering the Model(required)

The water discharge entering the model is prescribed on the Q-Record, but **IT IS DIFFERENT FROM PREVIOUS VERSIONS OF HEC-6**. This Q-Record contains water discharges entering each segment of the network at the **UPSTREAM** end rather than leaving at the downstream end. When there is only 1 segment and no local inflow points, the-Record is the same as old versions of HEC-6. However, when local inflows are present or when there are several segments, new Q-Records must be coded.

The program associates Discharge with location in the network by the position of that discharge on the Q-Record. Field 1 is always the Downstream most inflow point. The program expects the discharges to be coded in sequence by segment, see printout table entitled NETWORK STRUCTURE.

Example:        FIELDS

```

1234567 1234567 1234567 1234567 1234567 1234567 1234567 1234567
*    B A EVENT 0 .. CONDITION THE NETWORK
Q    -1        -2        -3    350000
R    .6
T                    40
W    .1

```

Field	Variable	Value	Description
0		Q	RECORD Identifier goes in Col 1-2
1	Q(1)	+	The First Water discharge entering the network. This is assigned to the first segment to have a water inflow boundary condition. It could be a Local inflow or it could be the upstream boundary condition inflow.
		-	Code as negative if flow is in the upstream direction or if it is a local outflow.
2	Q(2)	+	The second water discharge entering the network. Continue coding the inflows in the sequence of the segmentes until all inflow points have been satisfied.
		-	ETC
10	Q(I)	+,-	If more than 10 values are required, continue coding in FIELD 1 of the next Q-Record.

**G-4 R-Record - Downstream Water Surface Elevation Boundary Condition (required)**

A starting water surface elevation **is required** at the downstream boundary of the model for every time step. HEC-6 provides three methods for prescribing this downstream boundary **value**: (1) a rating curve, (2) **R**-Records, or (3) a combination of a rating curve and **R**-Records.

The first method involves the use of a rating curve which can be specified using a **\$RATING**-Record followed by a set of **RC**-Records containing the water surface elevation data as a function of discharge. The rating curve need only be specified once at the start of the hydrologic data (immediately following the **\$HYD**-Record) and a water surface elevation will be determined by interpolation using the discharge given on the **Q**-Record for each time step. The rating curve may be temporarily modified using the **S**-Record or replaced by entering a new set of **\$RATING** and **RC**-Records before and **\***-Record in the hydrologic data.

In Method 2, **R**-Records are used **instead** of a rating curve to define the water surface elevation. To use this method, and **R**-Record is required for the first time step. The elevation entered in Field 1 of this-Record will be used for each succeeding time step until another **R**-Record is found with a non-zero value in Field 1 to change it. In this way, you need only inset **R**-Records to change the water surface elevation to a new value.

Method 3 is a combination of the first two methods. This method makes it possible to use the rating curve most of the time to determine the downstream water surface elevation while still allowing the user to specify the elevation exactly at given time steps. In this method, the **R**-Record's non-zero Field 1 value for the downstream water surface elevation will override the rating curve for that time step. On the next time step, the program will go back to using the rating curve unless another **R**-Record is found with a non-zero value in Field 1.

**R**-Records have a secondary purpose. They are used to define the water surface elevation at certain internal control points in the geometry. The location of internal control points is defined using **X5**-Records. **R**-Records are necessary to define the water surface at those internal control points where the UPE option on the **X5**-Record has not been set (**X5.2**) and

**R-Record (continued)**

the active field value is prescribed. The water surface elevation (UPE) for that time step will be read from the **R**-Record at the field prescribed on the **X5**-Record (**X5.4**). Note that if a value is given for HLOS (head loss) on the **X5**-Record, that value **will** be used in conjunction with the water surface elevation (UPE) value found on the **R**-Record.

In the case of a distributary, code the elevations across the R-Record in the sequence of the Segments: i.e. Code the Elevation for Segment 1 in field 1, the Elevation for Segment 2 in field 2, etc. The program will retain these elevations. Enter new values when the elevations need to be changed.

```
Example:   FIELDS
1234567 1234567 1234567 1234567 1234567 1234567 1234567 1234567 1234567
*   B A EVENT 0 .. CONDITION THE NETWORK
Q   -1      -2      -3  350000
R   .6
T                               40
W   .1
```

Field	Variable	Value	Description
0		R	RECORD Identifier goes in Col
1	R()	+	The Water Surface Elevation for Segment 1
2	R()	+	In the case of a distributary, enter the Water Surface Elevation for segment in Field 2.
	.		
	.		
	.		
10	Q()	+	If more than 10 values are required, continue coding in FIELD 1 of the next Q-Record.

**G-5 S-Record - Rating Shift (Optional)**

This-Record allows the user to alter the starting water surface elevation by a constant value. This alteration will remain in effect for succeeding time steps until another S-Record is read with a new shift value.

```

Example:           FIELDS
1234567 1234567 1234567 1234567 1234567 1234567 1234567 1234567 1234567
*   B A EVENT 0 .. CONDITION THE NETWORK
Q   -1      -2      -3  350000
R   .6
S   -2
T                               40
W   .1

```

Field	Variable	Value	Description
0	ICG	S	Record identification (Column 1).
1	SHIFT(1)	+,-	Enter the rating shift for starting water surface elevations at Control Point 1. All starting elevations read for Control Point 1 will be shifted by the value of SHIFT for this and subsequent events until a new S-Record is read.
		b,0	Return SHIFT to zero at Control Point 1.
2	SHIFT(2)	+,-	Same description for Second Downstream Boundary Control Point. Note: The SHIFT values are position dependent on the S-Record - not control point dependent. That is, the second control point having a Downstream Boundary Condition may not be Control Point 2. It may be 3 ... etc, but the SHIFT value goes in Field 2.
3	SHIFT(3)		Continue coding up to 10 values. Program does not permit shifting more than 10 Control Points.
ONLY 1 S-RECORD IS PERMITTED PER EVENT.			

**G-6 T-Record - Water Temperature (Optional)**

The **T-Record** provides water temperature data (refer to Chapter 3, Section 3.4.2 in the HEC-6 User's Manual). This-Record is required only in the first time step. Include subsequent **T-Records** only if the water temperature changes. The water temperature(s) entered on this-Record will remain in effect until another **T-Record** is entered to change it. Water temperature is important for computing sediment settling velocity. Its becomes more importance as particle size becomes smaller.

The water temperature is still prescribed on the T-Record, but **IT IS DIFFERENT FROM PREVIOUS VERSIONS OF HEC-6**. The T-Record in HEC-6T contains water temperature for discharges entering each segment of the network at the **UPSTREAM** end rather than the values leaving at the downstream end.

Code a water temperature for each inflowing water discharge on the Q-Record as shown in the following example. The 350,000 cfs value is the mainstem inflow, and the water temperature is 40 degrees Fahrenheit. The negative Q's are local outflows, and the program uses the ambient water temperature for outflows. Any inflow, be it mainstem or local, must have a water temperature value.

```

Example:           FIELDS
1234567 1234567 1234567 1234567 1234567 1234567 1234567 1234567 1234567
*   B A EVENT 0 .. CONDITION THE NETWORK
Q   -1      -2      -3  350000
R   .6
T                               40
W   .1

```

Field	Variable	Value	Description
0		T	RECORD Identifier goes in Col 1
1	WT(1)	33 <WT< 211	Temperature for the Water Discharge in Q.1
2	WT(2)	"	Temperature for the Water Discharge in Q.2
	.		
	.		
	.		
10	WT(I)	"	If more than 10 values are required, continue coding in FIELD 1 of the next T-Record.

**G-7 W-Record - Computation Time Step (required)**

The **W-Record** contains the computation time step. The water discharge hydrograph is partitioned into short intervals for calculating the sedimentation processes. Each interval is called an **EVENT**. The water discharge is constant during each event, and the length of the event becomes the computation time step for the numerical integration. Each time step can be different (refer to Chapter 3, Section 3.4 and Figure 3.7 of the HEC-6 User's Manual).

```

Example:           FIELDS
1234567 1234567 1234567 1234567 1234567 1234567 1234567 1234567 1234567 1234567
*   B A EVENT 0 .. CONDITION THE NETWORK
Q   -1      -2      -3  350000
R   .6
T
T
W   1
    
```

Field	Variable	Value	Description
0	ICG	W	Record identification (Column 1).
	DD(1)	+	<b>The computation time step.</b> Code this time in days or fractions of a day.
2-10	DD(2)..DD(10)	+	<b>Obsolete - The parallel discharge option should not be used.</b>

**G-8 X-Record - Alternate Format for Coding Computational Time Step**

The X-Record may be used to define the computation time step, in place of the W-Record. The purpose, of the X-Record is to partition the time of a single event, the time on a W-Record, into shorter intervals for the numerical computations. For example, this need arises when unstable computation steps are not detected until after the hydrologic data has been assembled using the traditional W-Record approach. The X-Record allows the computation time interval to be shortened without requiring additional event data sets (\*, Q, W-Record sets) to be inserted into the hydrologic data. To use X-Records, replace the W-Record with an X-Record coded with one of the following options.

Note: When printing with X-Records, only the final computation step is printed. This is appropriate for displaying results, but it is misleading when debugging. Always convert X-Records to W-Records when debugging.

```
Example:           FIELDS
1234567 1234567 1234567 1234567 1234567 1234567 1234567 1234567 1234567 1234567
*   B A EVENT 0 .. CONDITION THE NETWORK
Q   -1      -2      -3  350000
R   .6
T                               40
X           .1      1
```

**Coding Option #1**

Field	Variable	Value	Description
0	ICG	X	Record identification (Column 1).
1			Leave blank.
2	DT	+	<b>Computation Time</b> in days. Should be the exact multiple of the duration of this event.
3	DD	+	<b>The Duration</b> of this Event in days. This is the value coded in a W--Record:  i.e. $DD \div DT$ is the number of computational time steps that will be used.
4-10			Leave blank.

**X**

HEC-6 Input Description  
Hydrologic Data

**X**

**X Record - (Continued)**

**Coding Option #2**

This coding option is useful for prescribing the exact time for the event. It must be the total accumulated time since the start of the run.

```

Example:           FIELDS
1234567 1234567 1234567 1234567 1234567 1234567 1234567 1234567 1234567 1234567
*   B A EVENT 0 .. CONDITION THE NETWORK
Q   -1   -2   -3 350000
R   .6
T
T
X   1   .1

```

Field	Variable	Value	Description
0	ICG	X	Record identification (Column 1).
1	TCH	+	<b>The Total Accumulated Time</b> in days at the end of this Event. This value must be greater than the accumulated time at the end of the previous event.  The duration of this event equals TCH minus the accumulated time at the end of the previous event.
2	DT	+	<b>Computation time step</b> in days. Should be the exact multiple of the duration of this event.  Event duration divided by DT equals the number of computational time steps that will be used.
3-10			Leave blank.

**X**

## HEC-6 Input Description Hydrologic Data

**X****X Record - (Continued)****Coding Option #3**

This coding option is useful for partitioning a computation time step into *n*-sub intervals

```

Example:           FIELDS
1234567 1234567 1234567 1234567 1234567 1234567 1234567 1234567 1234567 1234567
*   B A EVENT 0 .. CONDITION THE NETWORK
Q   -1      -2      -3  350000
R   .6
T
T
X           1           4
  
```

Field	Variable	Value	Description
0	ICG	X	Record identification (Column 1).
1			Leave blank
2	DT	+	Computation time step in days.
3			Leave blank
4	INT		The number of computational sub-intervals that will be used.
5 - 10			Leave blank.

**\$\$END**

HEC-6 Input Description  
Hydrologic Data

**\$\$END**

**G-9      \$\$END-Record - Required**

Last-Record in the data file.

Field	Variable	Value	Description
0	ICG,IDT	\$\$END	Record identification (Columns 1 through 5).

## **APPENDIX H**

# **SPECIAL COMMANDS AND PROGRAM OPTIONS**



## SPECIAL COMMANDS AND PROGRAM OPTIONS

### H-1 \$AV Record - Compute Surface Area and Volume of Storage in Model (Optional)

The **\$AV** command instructs the program to calculate the surface area and storage volume in the model. It replaces the the X-Option on the \$VOL command. The following example illustrates two options:

H-1.1 When the \$AV command is used with no VJ or VR Records, the surface area, storage volume and cross section properties are calculated for the water surface profile just prior to the \$AV record in the input data file.

H-1.2 The \$AV command is requesting the surface area and storage volume at two elevations - 4450 and 4500. The Conveyance Limits are turned off so the entire cross section will be included in the calculations starting with station STST and ending with station ENST. (SEE XL-Record for STST and ENST). The Ineffective Area Option has not been prescribed so it will default to "ON." That will not include the cross section in the computations at elevations below the ineffective area elevations for Ineffective Area Option 10. The calculations obeyed both the X3 and XL-Record rules. The XL-Options are satisfied first and the X3-Options are satisfied last.

```
Example:          FIELDS
1234567 1234567 1234567 1234567 1234567 1234567 1234567 1234567 1234567

$HYD
$AV    A

$HYD
$AV    A    X3=ON XL=OFF
VJ     2
VR    4450    4500
```

Field	Variable	Value	Description
0	ICG,IDT	\$AV	Record identification (Columns 1 through 3).

HEC-6 Input Description  
Special Commands & Program Options

**\$AV, VJ,  
VR**

Column 8	ISI(6)	A	Additional printout showing end areas, top widths and reach lengths used in surface area - storage volume computations.
		B	Printout showing trace information from the STOVOL computations. (Not recommended for normal applications.)
	USEX3	[ON, OFF]	This option applies ineffective area rules in the calculation of Surface Area - Storage Volume. (See the X3-Record.) It does not replace or over-ride the USEXL option but works in addition to it.
		blank or ON	The Default is ON. Surface Area-Storage Volume computations obey the Ineffective Area Option 10 Rules (SEE X3-1).
		OFF	Calculations ignore the Option 10 Ineffective Area Constraint
	USEXL	ON,OFF	This option applies the Conveyance Limits rules in the calculation of Surface Area - Storage Volume. (SEE XL-Record.)
		ON	Obey the Conveyance Limits Rules.
		blank or OFF	The Default. Ignore the Conveyance Limits Rules and include the cross section from STST to ENST. NOTE: Unless STST and ENST were prescribed on an XL-Record, all of the cross section will included in the computations. This option works with the USEX3 - It does not over ride USEX3.

HEC-6 Input Description  
Special Commands & Program Options

**\$AV, VJ,  
VR**

**H-1.3 VJ Record - Elevation Table for Cumulative Volume Computations (Optional)**

This record tells the program how many elevations are coded on the following VJ-Record, what the slope of the surface plain is, and whether or not there are lateral restrictions on the cross section for calculating the surface area and storage capacity tables.

When calculating surface area - volume for the existing water surface profile omit the VJ and VR Records

```
Example:           FIELDS
1234567 1234567 1234567 1234567 1234567 1234567 1234567 1234567 1234567 1234567
$AV
VJ      1 .001667                               2
VR     200
```

Field	Variable	Value	Description
0		VJ	Record Identification.
1	JM	1 to 30	Enter the number of water surface elevations in the area and capacity tables.
NOTE: When computing surface area - storage volume for the existing water surface profile, omit the VJ and VR-Records			
2	AVGSLO	0,+	The slope of the computation elevation (i.e. the lid).
10	LIMNSS	0	Use the entire cross section.
		1	Limit area-capacity calculations to the Left overbank subsection when using standard HEC-2 cross section subdivisions. (i.e. Count the number of cross section subdivisions from left to right.)
		2	Limit calculations to the Channel Subsection with standard HEC-2 cross section subdivisions.
		3	Right overbank subsection when using standard HEC-2 input.

HEC-6 Input Description  
Special Commands & Program Options

**\$AV, VJ,  
VR**

**H-1.4 VR Record - Elevation Table for Cumulative Volume Computations (Required when using VJ-Record)**

This record tells the program what the starting elevations are for calculating the surface area and storage capacity tables.

Field	Variable	Value	Description
0	ICG,IDT	VR	Record identification.
1	ELSTO(1)	-,0,+	Enter up to thirty elevations in Fields 1 through 10 on this and succeeding <b>VR</b> records.

**\$B**

HEC-6 Input Description  
Special Commands & Program Options

**\$B**

**H-2      \$B-Record - Transmissive Boundary Condition (optional)**

The **\$B**-Record is used to change the sediment discharge crossing the downstream boundary from a calculated rate to the rate approaching from the next upstream section. Use this option when sediment deposits at the downstream boundary and there is no physical explanation for it (e.g., as in a supercritical flow reach when the sediment concentration is very high).

```
Example:                    FIELDS
1234567 1234567 1234567 1234567 1234567 1234567 1234567 1234567 1234567 1234567
$HYD
$B     2
*     Begin Coding hydrologic data ...
Q
R
T
W
...
```

Field	Variable	Value	Description
0	ICG,IDT	\$B	Record identification.
1 or 2	ISBT	1	Sediment discharge is calculated at the outflow boundary.
		2	Approaching sediment discharge is transmitted past the outflow boundary section without change.

**\$CL**

HEC-6 Input Description  
Special Commands & Program Options

**\$CL**

**H-3      \$CL-Record - Closed Loop (Optional)**

Command-Record which instructs the program that a distributary is present in the data set. In the example below, the initial estimate is that 70 % of the flow will pass down branch 1.

```
Example:                    FIELDS
1234567 1234567 1234567 1234567 1234567 1234567 1234567 1234567 1234567 1234567
$HYD
$CL 70            1            0            1            1
... Begin Coding Hydrologic Data
```

Field	Variable	Value	Description
0		\$CL	Record Identification
1	OQC	0 to 100%	Discharge Coefficient, percent, of Total Q flowing in Branch in next field. This value is used for the first estimate only.
2	NGDSL	+	The smallest segment number in the loop. Only Loops involving 2 Branches are permitted. NGDSL is always the smaller of the two segment numbers. The other segment leaving the control point must be numbered NGDSL + 1.
3	IDWAX	b,1	Instructs the program to calculate the flow distribution that will balanced the energy head at the junction at the upstream end of this segment. This is the default option.
		2	Calculate water surface profiles for the prescribed flow distribution and <b>do not</b> balanced the energy head at the junction. Rather, write the resulting discharges and heads to Tape17 at the junction.
4	ILOOP	+	Loop number for data on this-Record.
5	IZONE	+	Zone number for this Loop
		b	Default = 1

**H-4.1 \$DREDGE -Record - Dredging Option**

This command initiates dredging calculations to be performed at all cross sections where dredging parameters have been specified (See H\*-Series of Records, Geometric Data Set). Dredging will begin where the **\$DREDGE-Record** occurs. It will continue until all dredging criteria have been met. Then it will turn itself off. **DO NOT USE THE NODREDGE OPTION WITH HEC-6T.** Dredging can be turned on as often as desired.

```
Example:          FIELDS
1234567 1234567 1234567 1234567 1234567 1234567 1234567 1234567 1234567 1234567
*
Q
W
$DR      D      (Insert $DR after any W or X Record in the Hydrologic Data
$NODR Turn off Dredging any time, but immediately fits most situations
*          Resume coding hydrologic data sets with * or $-Record.)
Q
W
...
```

Field	Variable	Value	Description
0	ICG,IDT	\$DREDG	Record identification (Columns 1 through 6).
col 8	KSW	B	Extra Printout such as end area and bed layers in the dredged cross section and the volume dredged by cross section (reach).
		C	Trace printout for program debugging
col 9	KSL(3)	W	Waste the dredged material and do not include the volume in the accumulators displayed in the dredging printout.
col 10	IDRDIR	[ ],D	This flag controls the direction of dredging. The default direction is from downstream to upstream. Placing a D will change the direction from upstream to downstream.

**H-4.2 \$NODREDGE Record - Stop Dredging**

The presence of a **\$NODREDGE-Record** stops the dredging option selected by previous **\$DREDGE-Record**.

Field	Variable	Value	Description
0	ICG,IDT	\$NODREDGE	Record identification (Columns 1 - 9).

**H-4.3 DF-Record - Draft Option**

The depth of water required for navigation (draft) can be the criteria for initiating dredging. The program will use the cross section stations prescribed on the H-Series of-Records (See Geometric Data Set), but it will calculate the bottom elevation of the dredged cut by subtracting the draft, plus any over-depth from the H-Record, from the water surface profile elevation.

```
Example:          FIELDS
1234567 1234567 1234567 1234567 1234567 1234567 1234567 1234567
*
Q
W
$DR      D      (Insert $DR after any W or X Record in the Hydrologic Data
DF       9
DC      1      1      40000
*
*          Resume coding hydrologic data sets with * or $-Record.)
Q
W
...
```

Field	Variable	Value	Description
0	ICG,IDT	DF	Record identification (Columns 1 and 2).
1	DFT	+	Depth of water required for navigation.
		0,b	Program will compute dredging elevations by subtracting the DFT from the water surface elevation at the time the DF-Record was read.

**H-4.4 DC-Record - Dredging Capacity**

In some cases it desirable to dredge at a rate which resembles field equipment rather than instantaneously. The DC option allows one to prescribe a capacity for each dredging site. It also allows one to dispose of the dredged material into the water column. It should be used with Dredging Template option HL - not H or HD.

Field	Variable	Value	Description
0	ICG,IDT	DC	Record identification (Columns 1 and 2).
1	IDDR	1-10	Dredging site number.
2	IDSTY	+	Disposal Type.
		0	Material vanishes from the model.
		1	Material is disposed into the water column 1 cross section downstream from the reach being dredged.
		2	Material is disposed into the water column at first cross section downstream from dredging site IDDR (DC-1).
3	DRCAP	0,+	Dredge capacity in cubic yards per day
		0	Capacity defaults to 1.E+15 cubic yards/day (considered infinite)
		-1	Dredging Capacity set = 0

**\$EX**

HEC-6 Input Description  
Special Commands & Program Options

**\$EX**

**H-5      \$EX-Record - Exner Options**

The \$EX command controls the solution of the Exner Equation. The Exner Equation is the sediment continuity equation which controls bed sorting and armoring. The HEC-6 program distributed by HEC defaults to EXNER 5 solution. HEC-6T supported by Mobile Boundary Hydraulics defaults to EXNER 5. HEC-6W supported by WES defaults to EXNER 7.

To select an Exner Solution other than the default, place the \$EX-Record at the beginning of the input data file. If no \$EX command is present, the program interprets Bed Sediment Reservoir data coded on the H, HD or HL-Records according to a different rule for EXNER 1 & 5 than is used for EXNER 7. One may obtain significantly different results.

Field	Variable	Value	Description
0	ICG, IDT	\$EX	Record identification (Columns 1 through 3).
Column 8	ISI(6)	1	Original method in HEC-6. (Default option from September 1971 - 1984 and still available upon request).
		5	EXNER5 is the default option in HEC-6T at the time of this manual. It was the default option in the WES version of code from 1984 - August 1995 when WES began using HEC-6W. EXNER5 is the default option in the HEC version of HEC-6 released after November 1987.
		7	EXNER7 is the new solution of the bed sorting and armoring process. It was developed by R. R. Copeland. It is the default option for HEC-6W codes dated after August 1995.

**H-6      \$GR-Record - Cross Section Shape Option**

The original HEC-6 code retained the cross section shape coded on **GR**-Records and moved the Y-coordinates vertically by a constant amount after each time step.

The **\$GR**-Record allows the user to adjust the depth of deposit in a cross section to vary according to the depth of flow. Therefore, deeper portions of a cross section will receive more deposited material rather than a uniform depth of deposit. The Y-coordinates still move vertically but the amount of deposition depends on the depth of flow in the cross sections. Erosion is still a uniform value.

Field	Variable	Value	Description
0	ICG, IDT	\$GR	Record identification (Columns 1 through 3).
Column 8		[1,b]	The default. Move Y-coordinates by a constant amount after each computation.
		2	Vary the amount of deposition depending on depth.
		3	Limit the width of deposition to the dredged channel.

**H-7 \$HOT-Record - Resume a Run<sup>16</sup>**

This command is used to resume a run. The HOT start file is written by HEC-6T when the \$WRITE Command is encountered. The .HOT File cannot contain Geometry or Sediment Data. The Command should be inserted into the Hydrological Data set at the place where the \$WRITE command provided the .HOT file. Begin the .T5 file with the \$HOT command as shown in the following example. Do not include a \$HYD command in the file.

```
Example:          FIELDS
1234567 1234567 1234567 1234567 1234567 1234567 1234567 1234567 1234567
$HOT      YRU50FU
*   AB   This is this the first event in the hydrograph being resumed.
Q  10000
W      1
*       The Hydrological Data Set continues as in a normal run
Q  20000
W      1
...
etc
```

Field	Variable	Value	Description
0	ICG,IDT	\$HOT	Record identification (Columns 1 through 4).
1	FNHOT	name	Enter the name of the .HOT start file here.

---

<sup>16</sup> Reactivated December 6, 1994

**H-8      \$K-Records - Channel N Values by Relative Roughness (Optional)**

The model ignores the prescribed Manning's n-values for the channel (NC or NV-Records) when a \$KL-Record is encountered and calculates bed roughness as a function of the bed material gradation via Limerinos' (1970) relative roughness method (see Chapter 3, Section 3.7.1 in the HEC-6 User's Manual). To return to standard n-values insert a \$KI-Record.

```
Example:                    FIELDS
1234567 1234567 1234567 1234567 1234567 1234567 1234567 1234567 1234567
$KB                        2
```

Field	Variable	Value	Description
0	ICG,IDT	\$K	Record identification (Columns 1 and 2).
COL=3		I	Use n-Values from Input NC or NV-Records.
		B	Calculate bed roughness using Brownlie Equations
		L	Calculate bed roughness using Limerinos Equation
COL=2&3		IG	Must tell program to Ignore the error test for bank roughness values when using a B or L option to calculate bed roughness in a 3-strip model.
1	MCHRUF		Methods for Compositing Channel n-Values when bed and banks are prescribed separately. Overbank n-values are not included in the compositing.
		0	No Compositing. Use this for a 3 strip model.
		1	Alpha Method. Only Recommended for very wide channels.
		2	Equal Velocity Method

**H-9 \$MXMN - Save Maximum and Minimum Values (Optional)<sup>17</sup>**

This command will cause the program to sample each event and save the maximum and minimum water discharges, maximum and minimum water surface elevations, maximum and minimum bed elevations and the sediment discharge and concentration coincidental with the maximum and minimum water discharges.

In the following example, the second \$MXMN command turns off the request and causes the results to be printed.

```

Example:           FIELDS
1234567 1234567 1234567 1234567 1234567 1234567 1234567 1234567 1234567 1234567
$MXMN 3      3      3      0
...
$MXMN

```

Note: This-Record turns off the Max/Min Tests

Field	Variable	Value	Description
0		\$MXMN	RECORD Identifier goes in Col 1-5.
			A blank \$MXMN-Record turns off the Max/Min Tests and Prints the results.
1	MXMNQ	3	Save both the maximum and the minimum water discharges at each cross section.
		2	Save the Minimum Water Discharge at each cross section.
		1	Save the Maximum Water Discharge at each cross section.
		0	Turn off Maximum/Minimum Tests For Water Discharge. <b>NOTE: Blank is not the same as 0 on this-Record. Code the 0</b>
		.	.
2	MXMNWS	3	Save both the maximum and the minimum water surface Elevations at each cross section.
		2	Save the Minimum Water Surface Elevation at each cross section.

<sup>17</sup> Prepared: January 10, 1995

**\$MXMN**

HEC-6 Input Description  
Special Commands & Program Options

**\$MXMN**

Field	Variable	Value	Description
		1	Save the Maximum Water Surface Elevation at each cross section.
		0	Turn off Maximum/Minimum Tests for Water Surface Elevation.
3	MXMNBS	3	Save both the maximum and the minimum Bed Surface Elevations at each cross section.
		2	Save the Minimum Bed Elevation at each cross section.
		1	Save the Maximum Bed Elevation at each cross section.
		0	Turn off Maximum/Minimum Tests for Bed Surface Elevation.
3	MXMNQS	3	Save, at each cross section, the Maximum Sediment Discharge and Concentration corresponding to the Maximum water discharge and the minimum Sediment Discharge and Concentration corresponding to the Minimum water discharge.
		2	Save, at each cross section, the minimum Sediment Discharge and Concentration corresponding to the Minimum water discharge.
		1	Save, at each cross section, the Maximum Sediment Discharge and Concentration corresponding to the Maximum water discharge.
		0	Turn off Maximum/Minimum Tests for Sediment Discharge

**H-10      \$OQC Data Set - Flow Distribution Coefficients**

**H-10.1      \$OQC-Record - Command Record <sup>18</sup>**

The Command Record for water discharge distribution coefficients that follow on OC-Records.

```

Example:           FIELDS
1234567 1234567 1234567 1234567 1234567 1234567 1234567 1234567 1234567 1234567
$HYD
$OQC
OC      2      1      70
OC      2      2      30

```

Field	Variable	Value	Description
0	ICG, IDT	\$OQC	Record identification.

---

<sup>18</sup> Modified: August 19, 1996

**H-10.2 QC-Records - Flow Distribution Coefficient Records**

Water Distribution Coefficients for the program to use to make the first estimate of the water discharge entering each Segment of a Closed Loop Network. These coefficients are needed at each control point having more than one outflow. Such is the case for Distributaries or closed loop networks. Enter One QC-Record for each distributary or outflowing segment in a closed loop. The coefficients must sum to 1.0 at each control point. Do not enter a coefficient for the inflow segments.

```

Example:           FIELDS
1234567 1234567 1234567 1234567 1234567 1234567 1234567 1234567 1234567
$HYD
$OQC
OC      2      1      70
OC      2      2      30

```

Field	Variable	Value	Description
0		OC	Record Identification
1	NCPL	+	Control Point Number
2	NGDSL	+	Segment Number for this-Record.
3	OQC(NGDSL)	0-100	Percent of Control Point outflow entering Segment NGDSL. Calculations use the water inflow to Control Point No. NCPL. (Note: OQC values at Control Point NCPL must sum to 100% .)

**H-11      \$PLOT-Record - Plot Option<sup>19</sup>**

The Plot command instructs the program to write output files in DSS form. To plot with MBH graphics, attach a P to the plot command as follows: \$PLOT P. The available plots are explained in Chapter 10 and summarized in the table below. The \$PLOT-Record is inserted in the HYDROLOGIC DATA SET where the plot(s) is(are) desired.

```

V PLOT(1) = 'TOTAL WATER DISCHARGE      '
V PLOT(2) = 'CHANNEL DISCHARGE         '
V PLOT(3) = 'TOP WIDTH                 '
V PLOT(4) = 'AVERAGE BED ELEVATION     '
V PLOT(5) = 'SLOPE                     '
V PLOT(6) = 'CHANNEL VELOCITY          '
V PLOT(7) = 'CHANNEL N-VALUE           '
V PLOT(8) = 'WATER SURFACE ELEVATION    '
V PLOT(9) = 'BED SURFACE ELEVATION     '
V PLOT(10) = 'EFFECTIVE WIDTH           '
V PLOT(11) = 'EFFECTIVE DEPTH           '
V PLOT(12) = 'SAND DISCHARGE RATE      '
V PLOT(13) = 'SILT DISCHARGE RATE      '
V PLOT(14) = 'CLAY DISCHARGE RATE      '
V PLOT(15) = 'X-SECTION COORDINATES    '
V PLOT(16) = 'X-SECTION WITH WS ELEV   '
V PLOT(17) = 'TOP BANK PROFILES        '
V PLOT(18) = 'ACCUM VOLUME PROFILES    '
V PLOT(19) = 'ACCUM SURF AREA PROFS    '
V PLOT(20) = 'TOTAL CLAY INFLOW, TONS   '
V PLOT(21) = 'ACCUM CLAY DELIVERY, TONS'
V PLOT(22) = 'TOTAL SILT INFLOW, TONS  '
V PLOT(23) = 'ACCUM SILT DELIVERY, TONS'
V PLOT(24) = 'TOTAL SAND INFLOW, TONS  '
V PLOT(25) = 'ACCUM SAND DELIVERY, TONS'
V PLOT(26) = 'ACCUMULATED DEP/ER, CY   '
V PLOT(27) = 'CHANGE IN AVG BED ELEV.  '
V PLOT(28) = 'MAX/MIN Q PROFILES       '
V PLOT(29) = 'MAX/MIN WS ELEVATIONS    '
V PLOT(30) = 'MAX/MIN BED ELEVATIONS   '
V PLOT(31) = 'MAX/MIN SED DISCHARGE    '
V PLOT(32) = 'MAX/MIN SED CONC         '
V PLOT(33) = 'SHEAR STRESS & THRESHOL '

```

The PLOT-Record is read with a free field format. It must contain the word TITLE (ALL CAPS) for the

---

<sup>19</sup> Modified: January 23, 1997

**\$PLOT[P]**

HEC-6 Input Description  
Special Commands & Program Options

**\$PLOT[P]**

**\$PLOT-Record - Plot Option (Continued)**

code to expect a titling string. Put the titling string in " ". The title can be up to 20 Characters. Separate the plot types with a comma or a blank. Both Title and Plot types can be changed within the run. When placed as above, the first plot will show the initial BED profile and the cross sections in the model. No hydraulic or sediment parameters are available for plotting because this location in the file is before the first event.

**H-12      \$PRT-Record - Selective Printout Option**

This data set does not request output. It restricts printout to selected cross sections for all print options in the Hydrologic Data set (SEE description of columns 5 and 6 on the \*-Record, Hydrologic Data Set.)

This set of input-Records, \$PRT-CP-[PS,PN], is referred to as the selective printout option. It is used to restrict output to specified cross sections. The selective printout will remain in effect until it is turned off by an \$PRT-Record with an ALL option.

Normally, selective printout will control all cross section output except the B-Level Table for Sedimentation output. It is possible to also include that table in the selective printout by requesting the B Option on the \$PRT-Record.

```

Example:           FIELDS
1234567 1234567 1234567 1234567 1234567 1234567 1234567 1234567 1234567 1234567

*   B  RUN 4
Q 90000 10000
W   1
$PR
CP   2      2
PS 0.78
CP   2      3
PN   1      2
*   C  RUN 5
Q 90000 10000
W   1

```

Field	Variable	Value	Description
0	ICG,IDT	\$PRT	Record identification (Columns 1 through 4).
Column 8	ISI(6)	N	Turn Printout OFF at all sections.
		A	Turn Printout ON at all sections.
"	PRINTBL		Option to apply Selective Printout to SB-2 Tables.
		B	Only those Cross Sections Selected on the following PN or PS-Records will be printed in the SB-2 Table.
		blank	The SB-2 Sediment Table is not affected by selective printout.

**H-12.1 CP-Record - Control Point for Selective Printout**

The CP-Record, in the old HEC6 code, prescribed the stream segment for which the cross sections on the following PN or PS-Record(s) apply. It is still recognized; however, the \$SEG-Record is more consistent with current version and can be used in place of the CP-Record. (SEE Geometric Data Set)

Field	Variable	Value	Description
0	ICG,IDT	CP	Record identification.
1	NCP	+	Control Point Number.
		b	In this case, the program only uses the Stream Segment Number so NCP can be left blank.
2	NGDS	+	Stream segment number.

**H-12.2 PN-Record - Cross Section Sequence Number for Selective Printout**

Use the PN-Record to prescribe the cross section sequence number where output is desired. The limit is 10 cross sections. Note that each PN-Record must follow a CP-Record to prescribe the segment of the network for which print out is being requested.

Field	Variable	Value	Description
0	ICG,IDT	PN	Record identification.
1-10	IPXS	+	Enter the index numbers of the desired cross sections. No. 1 is the downstream most cross section on the segment. Count in the upstream direction. Restart the count at 1 for each new segment in the network. The program prints output for the IPXSth cross section on segment NGDS (CP.2).

**\$PRT, CP,  
[PS, PN]**

HEC-6 Input Description  
Special Commands & Program Options

**\$PRT, CP,  
[PS, PN]**

**H-12.3 PS-Record - Cross Section Identification(River Mile) for Selective Printout**

Use the **PS**-Record to prescribe the cross section identification (channel station or river mile) number where output is desired. The limit is 10 cross sections.

Field	Variable	Value	Description
0	ICG,IDT	PN	Record identification.
1-10	SECID	+	This-Record works exactly like the PN-Record. Sometimes it is more convenient to prescribe cross section identification rather than sequence number. Enter up to 10 cross section identification (X1-1) values. The program will location those cross sections in the cross section array and determine the proper sequence number for printout.

**H-13 \$RATING - Tailwater Rating Curve Boundary Condition (Optional)**

**H-13.1 \$RATING Command Record**

HEC-6 provides two methods for prescribing the downstream boundary condition (i.e. the tailwater). One is the R-Record and the other is a tailwater rating curve.

The **\$RATING**-Record tells the program that a set of **RC**-Records, containing the rating curve points, will follow. A new **\$RATING** can be input, or an existing one changed, between "EVENT DATA SETS" in the hydrologic data. The following example shows one, along with some other Command Records, before the first event data set.

```

Example:          FIELDS
1234567 1234567 1234567 1234567 1234567 1234567 1234567 1234567 1234567

$HYD
$KI      2
$RATING 1
RC      31      1000      0      -6      198.0      198.3      200.1      202.1      204.0
RC      206.0      206.8      207.4      208.0      208.8      209.5      210.0      210.5      211.0
RC      211.5      212.0      212.6      213.0      213.5      214.0      214.5      214.9      215.3
RC      215.7      216.2      216.6      216.9      217.3      217.7      218.1      218.6
$SED
LR NONAM      .1      3      1
*   AB      Event 1
Q      2000
T      55
W      .1
...

```

Field	Variable	Value	Description
0	ICG,IDT	\$RATING	Record identification (Columns 1 through 7).
2	NCPDB	1,3	Control point number where this Rating Curve applies. (Note: Program uses a Free Field Read to extract this numeric data.)

# \$RATING, RC

## HEC-6 Input Description Special Commands & Program Options

# \$RATING, RC

Field	Variable	Value	Description
0	ICG,IDT	RC	Record identification.
1			Leave blank.
2	MNI	+	The number of water surface values that will be read. (May not exceed forty).
3	TINT	+	The discharge interval between water surface values in cfs. Use as small as interval as desired, but it must be a constant for the full range of water surface elevations that follow.
4	QBASE	+	If the first discharge in the table is not zero enter its value here in cfs.
5	GZRO	+	If the rating table is a stage-discharge curve rather than elevation-discharge, enter gage zero here.
6	RAT(1)	+	Lowest <b>water surface elevation or stage</b> goes here.
7-10	RAT(2)... RAT(MNI)		Continue entering <b>water surface elevation or stage values</b> defining the rating curve using Fields 7-10 on this-Record and Fields 2-10 on continuation <b>RC</b> -Records. A maximum of forty points can be entered to define the curve.

**14 \$RE Record - Recirculate Option**

The recirculating option causes HEC-6T to take sediment passing a cross section and re-circulate it to become the inflowing sediment discharge for the next event. Therefore, several events having the same discharge and tailwater elevation should be coded into the hydrological data set when using this option. Do not attempt to use this option in a stream network. Determine the inflowing sediment load for each segment before forming the segments into a network and code that load into the sedimentary data set.

```
Example:          FIELDS
1234567 1234567 1234567 1234567 1234567 1234567 1234567 1234567 1234567 1234567
$HYD
$RE      9
*          Event 1
Q 100000
R      22
T      60
W      1
*          Event 2
Q 100000
W      1
*          Event 3
Q 100000
W      1
*          Event 4
Q 100000
W      1

etc

$$END
```

# \$RE-CIRCULATE

## HEC-6 Input Description Special Commands & Program Options

# \$RE

Field	Variable	Value	Description
0	CMD	\$RE	Record identification. The program will match the characters coded with the string "RECIRCULATE". It does not require the entire string.
FreeField	IRECIR	+	Code the sequence number of the cross section where the sediment discharge is picked up for the re-circulation. This sequence number is counted from the Downstream End of the Model, and it is displayed in the Geometric Printout as cross sections are read.

**H-15. \$\$CRT-Record - Supercritical Flow Option**

HEC-6T does not calculate the supercritical flow profile at this time. However, the program tests for supercritical flow at every cross section, and when the test indicates that supercritical flow is possible, the program will automatically calculate the normal depth solution to the energy equation. This option recognizes that the slope is steep rather than mild, and it provides the supercritical velocity and corresponding normal depth to the sediment transportation calculation. HEC-6T is different from the Library Version of HEC-6 at this calculation. The library version will provide the velocity, depth, slope and width at critical depth, but it does not make the normal depth approximation for supercritical flow conditions.

The \$\$CRT Command-Record instructs HEC-6T to use the same computation as the Library Version.

```
Example:          FIELDS
1234567 1234567 1234567 1234567 1234567 1234567 1234567 1234567
$$CRT           OFF
```

Field	Variable	Value	Description
0	CMD	\$\$CRT	Record identification
FreeField	ICRTON	ON,OFF	The option is coded in field 2 of the \$\$CRT-Record
			Default is ON
		OFF	Use the values of velocity, depth, slope and width at critical depth. This the only calculation available in the Library Version

**\$SED, LP  
LR, LRATIO,  
LQ- LT-LF, END**

HEC-6 Input Description  
Special Commands & Program Options

**\$SED, LP  
LR, LRATIO,  
LQ- LT-LF, END**

**H-16 \$SED-Record - Water Discharge-Sediment Load Table (Optional)**

This program command option allows the user to change a sediment load table during a simulation. A change to a sediment load table can be made by either entering a new sediment load table definition on **LP, LQ, LT** and **LF**-Records or by altering the existing table with a ratio defined on **LP** and **LR**-Records. However, the new table must have **the same number of columns and rows as the original table.**

A **\$SED** command precedes a **LP, LQ, LT, LF**-Record combination that defines the discharge-sediment load rating curve. It can also precede a **LP, LR**-Record combination (see **LR**-Record). The **LP**-Record is used to specify the location where the modified sediment load table applies. It is required with either the **LQ, LT** and **LF**-Records or with the **LR**-Record. An **END**-Record is required as the last-Record to close the **\$SED** option.

If the sediment load table for the main stem or a tributary is to be replace, see the input descriptions for the **LQ, LT** and **LF**-Records for the Sediment data set. However, if the sediment load table for a local inflow or outflow is to be replaced, refer to the input description for the **LQL, LTL,** and **LFL**-Records in the Sediment data set instead (i.e. **LQ, LT, LF**-Records are used for the main channel and tributaries. The **LQL, LTL** and **LFL**-Records are used for local inflows and outflows).

```
Example:          FIELDS
1234567 1234567 1234567 1234567 1234567 1234567 1234567 1234567 1234567 1234567

$SED
$LOCAL
LP MAIN          1
LQ cfs           1 100000
LT t/d          .0002 500000
LF vfs          .20 .10
LF fs           .35 .30
LF ms           .20 .25
LF cs           .20 .20
LF vcs          .05 .15
END
```

Field	Variable	Value	Description
0	ICG,IDT	\$SED	Record identification (Columns 1 through 4).

**\$SED, LP  
LR, LRATIO,  
LQ- LT-LF, END**

HEC-6 Input Description  
Special Commands & Program Options

**\$SED, LP  
LR, LRATIO,  
LQ- LT-LF, END**

**H-16.1 LP-Record - Inflow Point Identification for Changing the Inflowing Load Table (Optional)**

The **LP**-Record defines the stream segment and/or inflow point whose sediment load table will be modified by the succeeding **LQ, LT, LF, or LR**-Records. NOTE: This version of HEC-6T REQUIRES A DIFFERENT LP-RECORD THAN HEC-6W AND PRIOR WES VERSIONS OF HEC-6. ALSO, THE LPOINT-RECORD IS NOT AVAILABLE FOR HEC-6T AT THIS TIME.

Field	Variable	Value	Description
0	ICG,IDT	LP	Record identification.
1	ISI	Comment	Any alphanumeric character comment.
2	NGDS	+	Segment number
3	NLIP	b,0,+	Local inflow/outflow point number. Blank is the same as 0 = no local inflow/outflow points
4	NCP	b,0,+	Control point number.
5	IDSD	b	Identifier. Leave blank for LQ-LT-LF-Records
		1	Enter 1 for LQ-SD-Records
6-10			Leave blank.

**\$SED, LP  
LR, LRATIO,  
LQ- LT-LF, END**

HEC-6 Input Description  
Special Commands & Program Options

**\$SED, LP  
LR, LRATIO,  
LQ- LT-LF, END**

**H-16.2 LR-Record - Ratio for Changing the Sediment Load Table (Optional)**

When changing the sediment concentration or discharge with the **\$SED** option, the existing sediment-discharge load table can be modified by entering an **LR-Record** with a multiplier constant, rather than by entering a whole new table. The following set of-Records are required to enter a change in the sediment discharge table using a load ratio.

```
Example:          FIELDS
1234567 1234567 1234567 1234567 1234567 1234567 1234567 1234567 1234567

$SED
LR          2          .9          1
LR          .9          1          1
```

Field	Variable	Value	Description
0	ICG, IDT	LR	Record identification.
1	ISI	Comment	Any alphanumeric character comment.
2	NCP	+	The Control Point number of sediment rating table to modify. (Usually the upstream end of the segment.) Required for main stem tables.
		0	Not needed for local inflows. See Fields 4 and 5
3	RATIO	+	The existing sediment-discharges in the rating table will be multiplied by RATIO.
4	NGDS	+	Enter the segment number.
		0	Not required for main stem inflows, but it helps interpret some printout tables. (See Field 2)
5	NLIP	+	Local inflow point Number on this segment. The numbering starts over with 1 at the downstream end of each new segment. Numbers increase in the upstream direction.
		0	Not needed for main stem inflows. See Field 2

**\$SED, LP  
LR, LRATIO,  
LQ- LT-LF, END**

HEC-6 Input Description  
Special Commands & Program Options

**\$SED, LP  
LR, LRATIO,  
LQ- LT-LF, END**

**H-16.3 LRATIO-Record - Ratio for Changing Sediment Load Table (Optional)**

When changing the sediment discharge with the **\$SED** option, the existing sediment-discharge load table can be modified by entering a **LRATIO**-Record with a multiplier constant, rather than by entering a new sediment load table.

```
Example:           FIELDS
1234567 1234567 1234567 1234567 1234567 1234567 1234567 1234567 1234567 1234567
*
Q
W
$SED
LRATIO           2           1           .8
*   B ...
```

Field	Variable	Value	Description
0	ICG,IDT	LR	Record identification.
1	ISI	Comment	Any alphanumeric character comment.
2	NGDS	+	The Segment Number for the sediment rating table.
3	NLOC	+	Enter the Local Inflow Point number. It starts at 1 for each new segment.
		b,0	Not a local inflow load table
4	RATIO	+	The existing sediment-discharges in the rating table will be multiplied by RATIO.

**\$SED, LP  
LR, LRATIO,  
LQ- LT-LF, END**

HEC-6 Input Description  
Special Commands & Program Options

**\$SED, LP  
LR, LRATIO,  
LQ- LT-LF, END**

**H-16.4 END-Record - Termination Record for the \$SED Option**

An **END**-Record is used to indicate the end of the changes made to the sediment load table(s). This-Record should be inserted after the last **LR** or **LF**-Record. If changes are to be made to more than one sediment load table sets of **LP, LR** or **LP, LQ, LT, LF**-Records may be stacked one after another. Insert the **END**-Record only after the last set of change-Records.

Field	Variable	Value	Description
0	ICG,IDT	END	Record identification (Columns 1 through 3).

# \$SMOOTH

# \$SMOOTH

## H-17. \$SMOOTH-Record - Smoothing Command

This command has three options: cross section smoothing, bank caving, and Model Bottom Elevation.

The cross section can become very irregular during a long term simulation containing periods of low flows. The \$SMOOTH Command record instructs HEC-6T to test the slope across the movable bed versus the angle of repose for sand. When the calculated values are less than 0.3, the program assumes the material to be sand and assigns 0.3 as the stable slope. Values larger than 0.3 are assigned as the angle of repose for that panel.

Bank caving is just a special case of the smoothing calculation. The program does not insert new caved bank coordinates into the cross section. Therefore, code extra points, using the [GE and GR] Records, as needed to capture the shape of the failed bank.

The third feature of the smoothing command is an option to prevent erosion below model bottom. This option is only needed when there is a hard bottom.

```
Example:           FIELDS
1234567 1234567 1234567 1234567 1234567 1234567 1234567 1234567
$HYD
$SMOOTH           ON           1
$RATING           1
RC                6           200           100           1.37           1.84           2.01           2.16           2.28
RC                2.39
*   AB           RUN 1
Q           1000
T           55
W           1
.
.
.
$$END
```

Smoothing is turned OFF by default. If smoothing is desired, place a \$SMOOTH-Record at the beginning of the HYDROLOGIC Data set. The following example illustrates a request for smoothing each time step. The command can be placed anywhere a COMMAND-Record is

permitted. Smoothing can be turned on or off when the user desires. Different smoothing intervals can be prescribed.

Field(1)	Variable	Value	Description
1	CMD	\$SMOOTH H	Record identification
2	ISMOPT	[ON, OFF]	Code the option in Field 2 of the \$SMOOTH-Record  Default is OFF. No smoothing calculations are made.
3	LSMO	[0, b]  +	The smoothing interval.  Program will default to a smoothing interval of 100 time steps. (Note: X-Records allow more than one time step per event.)  Prescribe the smoothing interval. It is the number of time steps between smoothing calculations.
4	IDBSR_TEMPLATE	b,0  1	Template option that controls the shape the Bed Sediment Reservoir as sediment is eroded from it.  This is the Historic HEC-6/6T rules. The program will test for the availability of sediment in the Bed Sediment Reservoir (BSR) using the mass of sediment. It does not consider the channel invert elevation. Continuity of mass is preserved, but the bed can erode below Model Bottom Elevation.  The elevation of the channel invert will not erode below the Elevation of Model Bottom

**H-18      \$SUBSID-Record - Subsidence Option**

This option allows areas to be modeled which are either settling or rebounding due to subsidence or uplift of the ground. It requires that each cross section be assigned a subsidence rate. (SEE HE-Records in the Geometric Data Set.)

```

Example:           FIELDS
1234567 1234567 1234567 1234567 1234567 1234567 1234567 1234567 1234567
$HYD
$SUBSID           ON           ON           ON           ON           0           10
*   B  RUN 1
Q  90000  10000
W           1

```

Field	Variable	Value	Description
0	CLINE	\$SUBSID	Record identification (Columns 1 through 7).
2	ISIDEX	ON,OFF	Command tells code whether or not to include cross section elevations in the Subsidence. (Note: SEE HE-Record for Rate of Subsidence)
3	ISIDEB	ON,OFF	Command tells code whether or not to include Tailwater Elevation in the Subsidence. (I.e. R or \$Rating Curve)
4	ISIDED	ON,OFF	Command tells code whether or not to include Dredged Channel Template in the Subsidence. (H-Records)
5	ISIDEV	ON,OFF	Command tells code whether or not to include \$VOL Elevations in the Subsidence. (See VJ- & VR-Records)
6	SIDETI	0,+	Enter the Time-in-Days between Subsidence calculations. In some cases it is not necessary to correct for subsidence every event and some computer time can be saved using this option.
7	SIDETS	0,+	Scaling Factor = Calendar Time/Model Hydrograph Time. The Subsidence rate is coded as feet/year. (This ratio is provided for those cases when low-low days are omitted from the model hydrograph. Fewer than 365 days will make a year.)

### H-19 \$TAPE12-Record - End of Run Data Set (Optional)

This command-Record controls writing the End of Job data file. Make this the first Record in the Data File. It has the general form:

```
$TAPE12  KT12=[ON,OFF], HE=[OLD,NEW,OFF], HL=[OLD,NEW,OFF], SED [ON,OFF], PF=[OLD,NEW,OFF], OF=[OLD,NEW,OFF],  
HYD[OLD,NEW,OFF]
```

#### Options:

1. If the \$TAPE12-Record is omitted, the program defaults to the historical option. (i.e. The geometric data file is written.) However, that file is now a complete geometric data set for HEC-6T whereas the historical option provided only the X1-GR-Records.
2. There is not an option to write a HEC-2 compatible TAPE12 file; however, the following command will write the X1-X3-GR and NC-NV-NH-Records into a file which can be edited for HEC-2.

```
Example:           FIELDS  
1234567 1234567 1234567 1234567 1234567 1234567 1234567 1234567 1234567 1234567  
  
$TAPE12 X3=OLD, HE=OFF, HL=OFF, SED=OFF, HYD=OFF  
$SEG   1       2       1
```

3. To write a \$TAPE12 file that will save the updated cross sections and the updated sediment gradations from the end of a run and then copy any hydrology data below the \$\$END-Record from the original \*.T5 file, use the following command:

```
Example:           FIELDS  
1234567 1234567 1234567 1234567 1234567 1234567 1234567 1234567 1234567 1234567  
  
$TAPE12 HE=OLD, HL=NEW, PF=NEW, OF=NEW, HYD=NEW  
$SEG   1       2       1
```

4. To write a \$TAPE12 file that will save the updated cross sections and the updated sediment gradations from the end of a run and then copy all hydrology data below the \$HYD-Record from the original \*.T5 file, use the following command:

\$TAPE12-Record - (Continued)

```

Example:          FIELDS
1234567 1234567 1234567 1234567 1234567 1234567 1234567 1234567 1234567
$TAPE12 HE=OLD, HL=NEW, PF=NEW, OF=NEW, HYD=OLD
$SEG  1      2      1

```

Field	Variable	Value	Description
0 <sup>20</sup>		\$TAPE12	Record Identification. <b>Use Upper Case Letters</b> for all Data on this Record.
	KT12		Write a TAPE12 at the END of RUN
		b, ON	The default option is "ON" I.e. A *.T12 File will be written at the End of Job if no \$TAPE12-Record is supplied.
		OFF	Prevents the program from writing a .T12 file.
	HE		Options for writing HE-Record (Erosion Limits) into the *.T12 File
		OLD	Copy the HE-Records from the .T5 file.
		NEW	Write HE-Records using Erosion Limits at the END of RUN.
		OFF	No HE-Record will be written into the .T12 File.
	HL		Options for writing HL-Record (Limits of Bed Sediment Reservoir) into the *.T12 File
		OLD	Copy the HL-Records from the .T5 file.
		NEW	Write HL-Records using values from END of RUN.
		OFF	No HL-Record will be written into the .T12 File.
	HYD12		Options for writing HYDROLOGIC DATA into the *.T12 file.
		OLD	Copy the HYDROLOGIC DATA from the *.T5 File Beginning with \$HYD
		NEW	Copy the HYDROLOGIC DATA from the *.T5 File Beginning after \$\$END

---

<sup>20</sup> This-Record is read with a Free Field Format. Leave a blank or place a comma between each option.

**\$TAPE12-Record - (Continued)**

Field	Variable	Value	Description
	PF		Options for writing PF-Records (Gradation of Bed Sediment Reservoir) into the *.T12 File
		OLD	Copy the PF-Records from the .T5 file.
		NEW	Write PF-Records using values from END of RUN.
		OFF	No PF-Records will be written into the .T12 File.
	OF		Options for writing OF-Records (Gradation of Bed Surface) into the *.T12 File
		OLD	Copy the OF-Records from the .T5 file.
		NEW	Write OF-Records using values from END of RUN.
		OFF	No OF-Records will be written into the .T12 File.
	NEWX3		Options for writing X3-Records (Ineffective Flow Area) into the *.T12 File
		OLD	Copy the X3-Records from the .T5 file.
		NEW	Write X3-Records using values from END of RUN.
		OFF	No X3-Records will be written into the .T12 File.
	NEWXB		Options for writing XB-Records (Separate Bed & Bank) into the *.T12 File
		OLD	Copy the XB-Records from the .T5 file.
		NEW	Write XB-Records using values from END of RUN.
		OFF	No XB-Records will be written into the .T12 File.
	NEWXC		Options for writing XC-Records (Separate Bed & Bank) into the *.T12 File
		OLD	Copy the XC-Records from the .T5 file.
		NEW	Write XC-Records using values from END of RUN.
		OFF	No XC-Records will be written into the .T12 File.
	NEWXD		Options for writing XD-Records (Separate Bed & Bank) into the *.T12 File

**\$TAPE12-Record - (Continued)**

Field	Variable	Value	Description
		OLD	Copy the XD-Records from the .T5 file.
		NEW	Write XD-Records using values from END of RUN.
		OFF	No XD-Records will be written into the .T12 File.
	NEWXL		Options for writing XL-Records (Conveyance Limits) into the *.T12 File
		OLD	Copy the XL-Records from the .T5 file.
		NEW	Write XL-Records using values from END of RUN.
		OFF	No XL-Records will be written into the .T12 File.
	SED12	b, OFF	The default option is "OFF" No Sediment Data will be written. (I.e. Sediment Data Begins with the T4-Record and Ends with LOCAL Inflow/Outflow Load Records.)
		ON	Write sediment data as requested by PF and OF options.

**H-20 \$UNET-Record - Unsteady Flow Hydrograph at every Cross section (Optional)**

The UNET command tells the program that the hydrologic data set will contain a water discharge for each cross section. The first Q, line 5 in the example below, goes with cross section # 1. The next Q is for cross section number 2, ... and they are read in sequence. Do not code the sequence number. Code Q in column 1 and the value in columns 2 - 8. Follow example data set 10 or example data set 11 in this document.

If local inflows/outflows are present, enter them after the last Q-Record (i.e. lines 16 and 43 below.) Code 1-Record for each branch having a local inflow point. For more than one local on a branch, code across the Record, one value in each field. Up to 10 locals are permitted, and all may be on the same branch). Code sequence is from downstream to upstream.

Water temperatures (T-Records) follow the same pattern as water discharges. Code one for each cross section. Enter new water temperatures as needed to change from the current values.

The tailwater elevation (R or \$RATING options) follows the T-Records. See the appropriate coding instructions in this appendix.

The following hydrology data set is for a network of 3 segments having 4 cross sections on each.

```

Example:           FIELDS
1      1234567 1234567 1234567 1234567 1234567 1234567 1234567 1234567 1234567 1234567
2      $HYD
3      $UNET
4      *   AB  RUN 1
5      Q   2000
6      Q   1800
...
15     Q    900
16     Q    800
17     R 5575.00
18     T    45
19     T    45
...
30     W    .1
31     *   AB  RUN 1
32     Q   2200
33     Q   2000
...
43     Q    800
44     W    .1
45     $$END

```

Field	Variable	Value	Description
0	UNET	\$UNET	Record Identification

**H-21      \$VOL-Record - Compute Cumulative Volume and Deposits at all Sections (Optional)**

The **\$VOL** command causes the program to calculate the cumulative bed change and load passing each cross section.

```
Example:                    FIELDS
1234567 1234567 1234567 1234567 1234567 1234567 1234567 1234567 1234567 1234567

$HYD
$VOL
VJ     1 .001667
VR     200
```

Field	Variable	Value	Description
0	ICG,IDT	\$VOL	Record identification (Columns 1 through 4).
Column 7	ISI(5)	X	Causes the program to look for a <b>VJ</b> -Record immediately after the <b>\$VOL</b> command and compute the storage volume for a table of elevations specified on succeeding <b>VR</b> -Records.
Column 8	ISI(6)	A	Additional printout showing cumulative weight of sediment passing each cross section by size class.
		B	"A" level printout plus extra trace information from the PRTVOL and STOVOL routines. (Not recommended for normal applications.)

**H-21.1 VJ -Record - Elevation Table for Cumulative Volume Computations (Required when using \$VOL)**

Data Record containing the number of elevations, the slope of the surface plain, and lateral restrictions for the surface area and capacity tables.

```
Example:           FIELDS
1234567 1234567 1234567 1234567 1234567 1234567 1234567 1234567 1234567 1234567
$VOL  X
VJ    1 .001667                2
VR    200
```

Field	Variable	Value	Description
0		VJ	Record Identification.
1	JM	1 to 30	Enter the number of water surface elevations in the area and capacity tables.
2	AVGSLO	0,+	The slope of the computation plain.
10	LIMNSS	0	Use the entire cross section.
		1	Limit area-capacity calculations to the Left overbank subsection when using standard HEC-2 cross section subdivisions. (i.e. Count the number of cross section subdivisions from left to right.)
		2	Limit calculations to the Channel Subsection with standard HEC-2 cross section subdivisions.
		3	Right overbank subsection when using standard HEC-2 input.

**H-21.2 VR-Record - Elevation Table for Cumulative Volume Computations (Required when using \$VOL-Record)**

Field	Variable	Value	Description
0	ICG,IDT	VR	Record identification.
1	ELSTO(1)	-,0,+	Enter up to thirty elevations in Fields 1 through 10 on this and succeeding VR-Records.

# \$WRITE & \$HOT

## HEC-6 Input Description Special Commands & Program Options

# \$WRITE & \$HOT

### H-22 \$WRITE-Record - Write a Resume File (Optional)

The **\$WRITE** command causes the program to write a restart file. It can be placed at any point in the hydrologic data set as any other command- Record. The program identifies the restart file by adding a .HOT extension to the input file name. If some other name is desired for the .HOT file, add that name to the \$WRITE-Record. SEE \$HOT for the description of the Resume command.

```
$HYD
* AB Event 1, Trace Discharge at the end of Year 2000
Q 2000
T 55
W .001
...
* AB Event 5000, Trace Discharge at the end of Year 2040
Q 2000
T 55
W .001
$WRITE YRU50FU.HOT
$PLOT TITLE = "TEST 26" 8,9,16,24
$$END
```

Field	Variable	Value	Description
0	ICG,IDT	\$WRITE	Record identification (Columns 1 through 6).
1	FNHOT	b	The program will write the current data into a file named <b>input_file_name.HOT</b> which can be used to resume the run.
		new_name	The program will write the current data into a file named <b>new_name.HOT</b> which can be used to resume the run.

**H-23      \$WSCP-Record - Water Surface Elevation Control Points (Optional)**

Command Record for the tailwater boundary condition. This Record is only needed when distributaries are present in the model. It tells the program which control points to apply the water surface elevations on the R and \$RATING-Records.

```

Example:           FIELDS
1234567 1234567 1234567 1234567 1234567 1234567 1234567 1234567
$WSCP  1      3
R      .6     .6

```

Field	Variable	Value	Description
0	LWSCP	\$WSCP	Record identification.
1	IWSCP(1)	+	The Water Surface coded in field 1 of the R-Record will be assigned to this control point number.
2	IWSCP(2)	+	The Water surface coded in field 2 of the R-Record will be assigned to this control point number.
etc			Code the Control Point Number for each Downstream Boundary in the Network.

# INDEX

3-strip .....	E-10, E-12, E-15, H-9
5-strip .....	E-10, E-12, E-15, E-18
ABORT .....	1-3, 6-1, D-3, E-18
Active Layer .....	7-2, 7-5, 7-6, 7-11, 7-12, 9-5, B-1, B-5-9, B-11, B-32, B-35, B-37, B-38, F-6, F-7, F-28, F-29
ALER .....	6-5, 11-3, B-1, E-4, E-6
ALPHA .....	6-9, D-11, D-15, D-16, E-5, E-7, E-29, F-1, F-10, G-4, H-9
Angle of Repose .....	8-4, H-29
Armor .....	7-5, B-5, B-10, F-25
ASCII .....	1-2, 6-6
Attenuation .....	6-1, 11-4, 11-9
Average Bed .....	6-9, 8-5, 8-6, 10-2, 10-4, 11-3, D-15, F-5, F-6, F-9, G-4
A-Level .....	6-8, 6-9, C-2, C-4, D-3, D-4, D-15, D-16, G-6
Backwater .....	6-1-3, 6-7, 11-4, B-1, B-6, B-20
Bank .....	2-3, 4-1, 6-7, 11-5, C-22, E-3, E-10, E-15, E-27, E-29-32, E-35, H-9, H-14, H-29, H-30
Top of .....	8-5, 10-3, 11-5, E-30
Basin .....	11-4, 11-9, 11-10, C-1, C-14, E-56
Bed . 2-4, 2-8, 3-1, 6-7, 6-9, 7-1-5, 7-9-12, 8-1, 8-3-6, 9-1, 9-3, 10-2-5, 10-10, 11-2, 11-3, 11-6, B-2-12, B-15, B-19, B-22, B-26, B-28-30, B-34-38, C-3, C-4, C-8, C-10, C-12-15, C-17, C-20, C-22, C-26, C-29, D-1, D-3, D-4, D-8-13, D-15, D-16, E-10, E-12, E-15, E-18, E-28, E-29, E-35, E-39-46, E-48-53, F-2, F-3, F-5, F-6, F-8, F-9, F-12, F-13, F-25-28, F-39, G-4, G-5, H-3, H-6, H-9-11, H-14, H-15, H-29, H-30, H-29, H-30, H-33	
Material . 4-1, 7-2, 9-6, B-5-7, B-12, B-13, B-16, B-17, B-19, B-22, B-37, B-38, E-40, F-6, F-8, F-9, F-12, F-13, F-25-27, G-5, H-3, H-5, H-7, H-9, H-29	
Roughness .....	3-1, 6-7, E-8, E-12, E-18, E-27, E-29, H-9
Wet .....	6-8, 7-1, 7-2, 8-1, B-11, B-24, B-26, B-34, B-36, B-37, C-24, C-26
Width . . . 1-3, 3-1, 6-7-9, 8-1, 8-5, 8-6, 9-1, 9-5, 10-1-4, B-7-9, B-11, B-34, D-4, D-10, D-11, D-15, D-16, E-28, E-29, E-32, E-35, E-39, E-43, E-48, E-51, G-4, H-7, H-14, H-23	
bed profile .....	10-5, D-12, H-15
Bed Sediment Reservoir . . . 2-4, 7-2, 7-12, 8-1, 10-3, 10-4, 11-2, 11-6, B-3, B-6, B-11, B-28, B-34, B-36, B-37, D-1, D-9, E-39, E-40, E-43, E-44, E-48, E-49, E-51, F-27, H-6, H-30, H-29, H-30	
Bottom Width .....	9-5
boundary condition . 2-3, 4-1-2, 7-1, B-13, B-14, B-18, B-27, B-28, B-34, C-4, C-5, D-4, D-11, F-19, F-23, G-7, G-8, G-10, H-1, H-19, H-36	
Boundary Conditions .....	2-3, 6-3, 7-1, 11-3, 11-7, B-27, C-6, D-3
by particle size .....	2-3, 4-1-3, 7-7, B-1-3, B-5, B-12, B-33, B-34, D-1, D-4, F-28, G-11
concentration . 3-3, 7-3-7, 7-9-12, 10-4, 11-2, B-6, B-9, B-14, F-13, F-16, F-20, F-24, F-30, F-32, F-34-36, F-38, F-40, H-1, H-10, H-11, H-26	
downstream . . 2-2, 2-3, 4-2, 6-1, 6-2, 6-5, 6-7, 7-1, 7-12, 9-6, B-2, B-5, B-6, B-12, B-14, B-16, B-18, B-22, B-23, B-27-32, B-34, B-36, B-38, C-2, C-4-6, C-8, D-1, D-4, D-7, D-9, D-15, E-1, E-2, E-26, E-27, E-34, F-7, F-10, F-14, F-25, F-30, G-7, G-8, G-10, G-11, H-1, H-3, H-5, H-17, H-19, H-22, H-26, H-32, H-36	
Internal .....	2-2, 2-3, 4-1, B-13, B-24, B-25, B-33, C-5, E-34, G-8
re-circulation .....	H-22
sediment . . 2-1, 2-3, 2-4, 3-1, 3-3, 4-1, 4-2, 5-1, 6-3, 6-7, 6-8, 7-1-12, 8-1, 8-4, 9-3, 9-6, 10-2-4, 11-2, 11-3, 11-6, 11-8, 11-10, B-1-17, B-22, B-24, B-26-28, B-30, B-31, B-33-38, C-2-4, C-6, C-8, C-10, C-12-15, C-17, C-20,	

	C-22, C-26, C-29, D-1, D-4, D-8-10, D-12, D-13, E-26, E-29, E-34, E-39, E-40, E-42-45, E-48-51, E-53, E-55, E-56, F-1, F-2, F-4, F-6-8, F-10-14, F-16, F-17, F-19-25, F-27, F-28, F-30-34, F-36-40, G-5, G-11, H-1, H-6, H-8, H-10, H-11, H-15, H-16, H-21-28, H-30, H-28-31, H-33
tailwater	4-1, E-34, H-19, H-21, H-31, H-32, H-36
upstream	2-2, 2-3, 6-1, 6-2, 6-4, 6-5, 6-7, 7-1, 7-12, 10-3, 10-4, B-2, B-6, B-9, B-12, B-13, B-16, B-29, B-31, B-33, B-34, C-2, C-4-6, C-8, D-4, D-7, E-1, E-2, E-19, E-23, E-24, E-34, F-7, F-10, F-14, F-15, F-25, F-27, G-7, G-11, H-1-3, H-17, H-26, H-32
water	1-1-4, 2-8, 4-1-3, 6-1-9, 7-1, 7-2, 7-4-7, 7-9-12, 8-5, 9-1, 9-6, 10-1-5, 10-10, 11-4, 11-8, 11-9, B-4-10, B-13-15, B-19, B-24-26, B-28, B-29, B-31, B-33, B-34, B-37, B-38, C-2, C-4-7, D-3, D-4, D-10-12, D-15, D-16, E-4, E-6, E-8, E-13, E-23-26, E-32, E-34-36, E-40, E-43, E-44, F-3, F-8, F-12, F-16, F-19-24, F-29-32, F-34-40, G-4, G-5, G-7-12, H-19, H-21, H-2, H-4, H-5, H-10-14, H-20, H-24, H-32, H-34, H-36
Branch	2-2-6, 6-1-6, 6-8, 7-1, 7-12, B-24, B-30, C-1-2, E-55, F-24, H-2, H-32
Brownlie	6-7, E-12, E-29, F-13, H-9
B-Level	6-8, 6-9, 10-2, B-16, D-3, D-4, D-15, H-16
Capacity	7-3, 7-5, 9-2-4, B-6, B-7, B-9, B-12, B-23, B-25, F-2, F-12, H-21, H-22, H-5, H-34
Card	7-1, 11-5, 11-7, 11-9, B-8, B-17, B-28, B-30, D-6, D-7
caving	H-29
Channel	2-3, 2-8, 6-7-9, 8-1, 8-5, 8-6, 9-1, 9-5, 10-1-4, 11-3, 11-5, 11-6, A-1, B-2, B-4, B-7, B-8, B-14, B-22, B-33, B-38, C-2, C-5, C-6, D-15, E-2-4, E-6-8, E-10, E-12, E-13, E-15, E-18-20, E-23-25, E-27-46, E-48, E-49, E-51, E-52, E-54-56, F-7, F-10, F-34, F-39, H-21, H-7, H-9, H-18, H-24, H-30, H-31, H-34
Banks	10-2, 10-3, E-29, E-30, H-9
channel bed	2-4, 2-8, 3-1, 6-7, 6-9, 7-1-5, 7-9-12, 8-1, 8-3-6, 9-1, 9-3, 10-2-5, 10-10, 11-2, 11-3, 11-6, B-2-12, B-15, B-19, B-22, B-26, B-28-30, B-34-38, C-3, C-4, C-8, C-10, C-12-15, C-17, C-20, C-22, C-26, C-29, D-1, D-3, D-4, D-8-13, D-15, D-16, E-10, E-12, E-15, E-18, E-28, E-29, E-35, E-39-46, E-48-53, F-2, F-3, F-5, F-6, F-8, F-9, F-12, F-13, F-25-28, F-39, G-4, G-5, H-3, H-6, H-9-11, H-14, H-15, H-29, H-30, H-29, H-30, H-33
station	2-8, 8-3, 8-4, 9-1, 9-5, 10-1-4, 11-2, 11-5, 11-6, B-4, B-9, B-17, B-18, B-21, B-26, B-36, B-37, C-20, E-18, E-19, E-21, E-27-30, E-33, E-35-38, E-40-46, E-48, E-49, E-51, E-52, F-7, F-10, H-19, H-18
strip	1-3, 6-7, 6-9, 11-2, 11-5, B-9, B-14, B-17, B-22, B-24, B-29, B-30, D-15, E-10, E-12, E-15, E-17-21, E-29, H-9
subsection	2-8, 6-8, 10-2, 10-3, 11-5, B-16-18, B-22, B-31, B-33, B-34, E-8, E-10, E-13, E-15, E-16, E-18, E-28, E-29, E-31, G-4, H-21, H-34
Clay	3-3, 7-2-7, 7-9, 7-12, 10-2-4, 11-7, B-2, B-3, B-5, B-7, B-10, B-12, B-13, B-15, B-16, B-21, B-22, B-25, B-26, B-30, B-32, B-33, B-36-38, D-4, D-13, F-1-6, F-8, F-10, F-22, F-24, F-25, F-27, F-30, F-33, F-36, G-5, H-14
deposition	2-4, 2-8, 3-3, 7-2-5, 8-1, 9-6, 10-4, 11-2, 11-7, B-1, B-2, B-5-8, B-25, B-27, B-36, E-35, E-40, E-43, E-46, F-3-9, H-7
erosion	2-4, 7-4, 7-5, 8-1, 10-3, 10-4, 11-2, 11-7, B-1, B-2, B-8, B-14, B-34, E-28, E-35, E-39, E-46, F-3, F-4, F-6-8, F-28, H-7, H-29
shear stress	6-7, 7-3-5, 11-2, 11-7, B-36, F-3, F-5, F-6, F-9
Closed Loop	6-3-6, 11-4, 11-6, B-2, B-6, B-9, B-12, B-14, B-21, B-24, B-33, B-34, B-38, F-23, G-6, H-2, H-13
coefficient	3-1, 6-3, 6-9, 9-3, 11-8, B-1-3, B-5, B-7, B-23, B-26, B-28, B-33, B-38, D-15, E-4, E-6, E-8, E-9, E-26, F-5, F-7, F-9, F-10, F-13-15, F-17, F-18, F-23, F-24, F-34, F-36-38, F-40, H-2, H-13
Cohesive Sediment	3-3, 7-3, 7-4, 7-6, B-37, F-4, F-6, F-7
Compaction	B-3-5, F-9
Composite	6-7, 6-8, 7-6, E-17-20, E-29
Conveyance	2-4, 10-3, 11-5, B-2, B-4, B-8, B-11, B-20, B-38, E-17-20, E-28, E-29, E-35, E-36, G-6, H-19, H-20, H-31
Roughness	3-1, 6-7, E-8, E-12, E-18, E-27, E-29, H-9
Specific Weight	7-6, 7-9-11, 9-3, 11-2, B-8, B-33, B-37

Computation Step .....	G-13
Computation Time .....	7-12, 11-8, B-5, B-7-9, B-11, B-12, B-32, E-34, F-2, G-12-15
Computational .....	2-1, 2-3, 7-11, B-1, B-6, B-8, B-9, B-12, B-33, B-38, D-3, G-13-15
Concentration .....	3-3, 7-3-7, 7-9-12, 10-4, 11-2, B-6, B-9, B-14, F-13, F-16, F-20, F-24, F-30, F-32, F-34-36, F-38, F-40, H-1, H-10, H-11, H-26
Confluence .....	6-6
Consolidation .....	7-2
Control Point .....	2-2, 2-3, 2-5, 4-1-3, 6-2, 6-5, 6-6, 11-4, 11-8, 11-9, B-1, B-12-14, B-17, B-18, B-24-28, B-33, B-38, C-2, C-4, C-5, D-3, D-6-8, E-2, E-34, E-56, G-10, H-2, H-13, H-17, H-19, H-25, H-26, H-36
Converge .....	6-3, 11-4, B-14
Convergence .....	6-5, 11-3, B-15, E-4
Conveyance .....	2-4, 10-3, 11-5, B-2, B-4, B-8, B-11, B-20, B-38, E-17-20, E-28, E-29, E-35, E-36, G-6, H-19, H-20, H-31
Coordinates .....	1-2, 8-4, 9-5, 10-3, 11-2, 11-5, B-8, B-26, B-32, E-5, E-7, E-37-40, E-43, E-49, E-52, G-4, H-7, H-14, H-29
Co-ordinate .....	8-3, B-6, B-14, B-16, B-25, B-26, B-28, B-30
Cross Section .....	1-2, 1-3, 2-2-4, 2-7, 2-8, 4-1, 4-2, 6-1-3, 6-7-9, 7-1, 7-11, 7-12, 8-1-6, 9-1, 9-3, 9-5, 9-6, 10-1-4, 11-2-6, 11-9, B-1-12, B-14-16, B-18-24, B-27-38, C-4, C-6, D-1, D-3, D-4, D-6, D-8, D-11, D-15, D-16, E-1, E-3-8, E-16-19, E-21, E-23, E-24, E-27, E-28, E-30, E-32-46, E-48-53, F-2, F-7, F-10, F-14, F-15, F-25-29, G-4, G-5, H-19-21, H-3-5, H-7, H-10, H-11, H-16-18, H-21-23, H-29, H-31-34
CS .....	C-8, C-10, C-11, C-22, C-29, D-8, F-17, F-19, F-23, F-31, F-34, F-37, H-24
curve .....	4-2-3, B-6, B-13, B-18, B-23, B-35, B-38, C-3, C-4, C-20, F-6, F-19, F-26-28, F-31, G-8, H-19, H-20, H-24, H-31
C-Level .....	1-3, 8-4, E-3
Data .....	1-1-3, 2-1-4, 2-7, 2-8, 4-1-3, 6-1, 6-5, 6-8-10, 7-12, 8-1, 8-4-6, 9-1, 9-2, 10-1, 10-3, 10-4, 11-1-9, B-2, B-7, B-8, B-10, B-11, B-13-17, B-20, B-22, B-23, B-27-32, B-37, B-38, C-41, C-1-6, C-8, C-10, C-12-15, C-17, C-20, C-22, C-26, C-29, D-1, D-3, D-7, D-8, D-10, D-11, D-14, D-15, D-17, E-1-4, E-6, E-8, E-12, E-17-19, E-24, E-26, E-27, E-37-39, E-44, E-46, E-49, E-54-57, F-1, F-4, F-6-11, F-17, F-18, F-24, F-25, F-27-31, F-33, F-36, F-37, F-39, F-41, G-3-8, G-10-13, G-16, H-19, H-1-4, H-6, H-8, H-12, H-14, H-16, H-17, H-19, H-21, H-24, H-29, H-31, H-28, H-29, H-31, H-32, H-34, H-35
Error .....	1-3, 11-1-3, 11-5, 11-7-9, B-1, B-4-6, B-10, B-15, B-18, B-20, B-25, B-27, D-1, E-4, H-9
Input .....	1-1-3, 2-2, 2-4, 4-1, 6-8, 7-9, 8-5, 8-6, 9-1, 9-2, 10-1, 10-3, 10-4, 11-1-4, 11-7, 11-9, B-7, B-8, B-10, B-11, B-14, B-15, B-17, B-18, B-22, B-29, B-33, B-37, B-38, C-41, C-1, C-2, C-8, D-1, D-3, D-7, D-10, D-17, E-1-4, E-6, E-8, E-10, E-12, E-13, E-15, E-23-25, E-27, E-29, E-31, E-32, E-34, E-35, E-37-39, E-43, E-46, E-48, E-51, E-54-57, F-1, F-2, F-4, F-6, F-8, F-10, F-11, F-14, F-16, F-17, F-19, F-23, F-25, F-27, F-28, F-30, F-41, G-3-8, G-10-13, G-16, H-19, H-21, H-1, H-2, H-6-10, H-12, H-14, H-16, H-19, H-23, H-24, H-31, H-28, H-32-36
Days .....	7-12, 11-8, B-1, B-5, B-8, B-10, B-34, C-7, D-4, D-11-13, G-4, G-12-15, H-31
Deck .....	2-8
Default .....	4-2, 6-5, 6-8, 7-3, 7-9-11, 8-1, C-5, E-4, E-17-19, E-21, E-26, E-29, E-30, E-39, E-43, E-45, E-49-51, E-53, F-5-10, F-13, F-16, F-28, H-19, H-20, H-2, H-3, H-6, H-7, H-23, H-29, H-30, H-29, H-31
DELEGL .....	6-6
Deposit .....	7-3, 7-11, 8-1, 11-2, B-8, B-22, B-32, F-4, H-7
Deposition .....	2-4, 2-8, 3-3, 7-2-5, 8-1, 9-6, 10-4, 11-2, 11-7, B-1, B-2, B-5-8, B-25, B-27, B-36, E-35, E-40, E-43, E-46, F-3-9, H-7
Depth .....	3-1-1, 6-7-9, 7-2-5, 8-4, 8-5, 9-1, 9-5, 10-2-11, B-13, B-22, B-25, B-27, B-28, B-32, B-35-37, D-10, D-15, E-8, E-10, E-11, E-13, E-14, E-17, E-18, E-20, E-21, E-29, E-39, E-40, E-42, E-43, E-45, E-48-51, E-53, F-12, F-29, H-4, H-7, H-14, H-23
Diagnostic Message .....	11-1
Dimensions .....	9-1, 11-2, 11-6, 11-8, B-26, D-1, D-10
Directory .....	10-5
Discharges .....	2-3, 2-4, 6-1, 6-3-5, 7-1, 7-10, 11-7, 11-9, B-24-26, B-30, C-2, C-4, C-5, D-3, D-4, D-10, E-15, E-16, F-3, F-20,

	F-30-32, F-34, F-35, F-37, F-39, G-7, G-11, H-2, H-10, H-26, H-27, H-32
Discharge-elevation	2-3, G-5
Disk	1-1
Distributaries	6-3, C-2, D-16, H-13, H-36
Distributary	2-2, 4-2, 6-3, B-18, B-33, C-1, C-3, C-14, C-15, F-23, G-9, H-2, H-13
Distribution	ii, 1-1, 6-3-6, 11-4, 11-8, B-14, B-26, B-29, B-33, C-1, C-3, D-11, D-15, D-16, F-3, F-23, F-24, G-4-6, H-2, H-12, H-13
at a junction	2-5, C-3
coefficients	2-1, 2-3, 2-7, 3-1, 6-8, 7-2, 7-3, 7-11, 11-8, B-3, B-14, B-22, B-28, B-31-33, C-3, E-8, F-4, F-7, F-10, F-12, F-14, F-15, F-17, F-18, F-23, F-24, F-34, H-12, H-13
flow	2-2, 2-3, 2-5, 6-1-9, 7-1-4, 7-8, 7-10-12, 11-3, 11-4, B-2-5, B-8-10, B-12-14, B-22, B-24, B-26, B-27, B-30, B-33, C-1, C-6, C-16, C-17, C-26, D-6, D-7, D-11, D-15, D-16, E-25, E-26, E-32, E-33, F-16, F-34, F-39, G-4, G-6, G-7, H-1, H-2, H-7, H-12, H-23, H-30, H-32
sediment	2-1, 2-3, 2-4, 3-1, 3-3, 4-1, 4-2, 5-1, 6-3, 6-7, 6-8, 7-1-12, 8-1, 8-4, 9-3, 9-6, 10-2-4, 11-2, 11-3, 11-6, 11-8, 11-10, B-1-17, B-22, B-24, B-26-28, B-30, B-31, B-33-38, C-2-4, C-6, C-8, C-10, C-12-15, C-17, C-20, C-22, C-26, C-29, D-1, D-4, D-8-10, D-12, D-13, E-26, E-29, E-34, E-39, E-40, E-42-45, E-48-51, E-53, E-55, E-56, F-1, F-2, F-4, F-6-8, F-10-14, F-16, F-17, F-19-25, F-27, F-28, F-30-34, F-36-40, G-5, G-11, H-1, H-6, H-8, H-10, H-11, H-15, H-16, H-21-28, H-30, H-28-31, H-33
Diversion	4-1, E-23, E-24, F-30, F-34-39
coefficients	2-1, 2-3, 2-7, 3-1, 6-8, 7-2, 7-3, 7-11, 11-8, B-3, B-14, B-22, B-28, B-31-33, C-3, E-8, F-4, F-7, F-10, F-12, F-14, F-15, F-17, F-18, F-23, F-24, F-34, H-12, H-13
sediment	2-1, 2-3, 2-4, 3-1, 3-3, 4-1, 4-2, 5-1, 6-3, 6-7, 6-8, 7-1-12, 8-1, 8-4, 9-3, 9-6, 10-2-4, 11-2, 11-3, 11-6, 11-8, 11-10, B-1-17, B-22, B-24, B-26-28, B-30, B-31, B-33-38, C-2-4, C-6, C-8, C-10, C-12-15, C-17, C-20, C-22, C-26, C-29, D-1, D-4, D-8-10, D-12, D-13, E-26, E-29, E-34, E-39, E-40, E-42-45, E-48-51, E-53, E-55, E-56, F-1, F-2, F-4, F-6-8, F-10-14, F-16, F-17, F-19-25, F-27, F-28, F-30-34, F-36-40, G-5, G-11, H-1, H-6, H-8, H-10, H-11, H-15, H-16, H-21-28, H-30, H-28-31, H-33
water	1-1-4, 2-8, 4-1-3, 6-1-9, 7-1, 7-2, 7-4-7, 7-9-12, 8-5, 9-1, 9-6, 10-1-5, 10-10, 11-4, 11-8, 11-9, B-4-10, B-13-15, B-19, B-24-26, B-28, B-29, B-31, B-33, B-34, B-37, B-38, C-2, C-4-7, D-3, D-4, D-10-12, D-15, D-16, E-4, E-6, E-8, E-13, E-23-26, E-32, E-34-36, E-40, E-43, E-44, F-3, F-8, F-12, F-16, F-19-24, F-29-32, F-34-40, G-4, G-5, G-7-12, H-19, H-21, H-2, H-4, H-5, H-10-14, H-20, H-24, H-32, H-34, H-36
DOS	1-1, 1-2
Dredged	7-2-6, 11-3, B-2, B-4, B-7, B-8, B-14, B-37, E-28, E-41, E-42, E-44, E-45, E-49, E-52, H-3-5, H-7, H-31
Dredging	9-1-3, 9-5, 9-6, 11-4, 11-6, B-5-8, B-14-16, B-25, B-27-29, B-32, B-35, C-24, E-28, E-39, E-41-45, E-48-53, H-3-5
EDIT	1-3, E-37
Editor	1-1, E-37
Effective Depth	7-3, 10-2, B-8, B-28, B-35, E-10
Effective Width	10-2, E-32
Einstein	E-17, E-29, F-12
END OF FILE	11-9
END OF JOB	1-2, 11-4, 11-10, B-27, D-14, F-16, G-5, H-28, H-29
ENDJOB	11-4, 11-10
END-OF-RUN	1-2
Energy	2-3, 4-1, 4-2, 6-4-9, 10-2, B-1, B-4, B-6, B-9, B-12, B-14, B-37, C-6, D-11, D-15, D-16, E-4, E-6, E-13, E-25, F-15, G-4, H-2, H-23
Equation	3-1, 4-3, 6-5, 6-7, 7-3, 7-9-12, 8-3-5, 9-3, 9-5, 10-3, 10-4, B-2, B-3, B-5, B-14, B-16, B-29, B-36, E-12, E-25, F-5, F-9, F-13, F-17-19, F-23, F-34, H-6, H-9, H-23
Head	2-3, 6-1, B-6, B-12, B-23, B-37-39, D-11, D-16, E-34, G-4, G-9, H-2
Line	6-5, 6-6, 6-8, 7-5, 10-2, B-1, B-6, B-9, B-10, B-23, B-24, B-37, C-2, D-1, D-11, D-15, D-16, E-4, E-6, F-28, G-4, H-32

Entrainment	7-2, 7-3, 7-5, 7-11, B-9
Equilibrium	7-2, 7-3, B-5, B-6, B-9, B-10, B-22, B-28, F-13
Erode	7-5, 8-1, B-22, H-30
erosion	2-4, 7-4, 7-5, 8-1, 10-3, 10-4, 11-2, 11-7, B-1, B-2, B-8, B-14, B-34, E-28, E-35, E-39, E-46, F-3, F-4, F-6-8, F-28, H-7, H-29
Erosional	8-1, F-6
Erratic	8-3
Error	1-3, 11-1-3, 11-5, 11-7-9, B-1, B-4-6, B-10, B-15, B-18, B-20, B-25, B-27, D-1, E-4, H-9
Abort	1-3, 6-1, D-3, E-18
Data	1-1-3, 2-1-4, 2-7, 2-8, 4-1-3, 6-1, 6-5, 6-8-10, 7-12, 8-1, 8-4-6, 9-1, 9-2, 10-1, 10-3, 10-4, 11-1-9, B-2, B-7, B-8, B-10, B-11, B-13-17, B-20, B-22, B-23, B-27-32, B-37, B-38, C-41, C-1-6, C-8, C-10, C-12-15, C-17, C-20, C-22, C-26, C-29, D-1, D-3, D-7, D-8, D-10, D-11, D-14, D-15, D-17, E-1-4, E-6, E-8, E-12, E-17-19, E-24, E-26, E-27, E-37-39, E-44, E-46, E-49, E-54-57, F-1, F-4, F-6-11, F-17, F-18, F-24, F-25, F-27-31, F-33, F-36, F-37, F-39, F-41, G-3-8, G-10-13, G-16, H-19, H-1-4, H-6, H-8, H-12, H-14, H-16, H-17, H-19, H-21, H-24, H-29, H-31, H-28, H-29, H-31, H-32, H-34, H-35
Fatal	1-1, 1-3, 11-1, B-30, D-14
INFO	11-1, B-16
MAGO	11-1, B-25
Message	1-3, 2-2, 7-11, 11-1, B-5, B-27
NOGO	1-3, 11-1, B-30
Tolerance	6-5, B-15
Event	ii, 1-1, 2-3, 4-2, 4-3, 6-6, 7-7, 8-1, 8-5, 9-1, 11-3, 11-4, 11-7-9, B-5, B-7-9, B-24, B-30, B-33, B-35, C-7, D-3, D-4, D-11, D-12, F-16, F-29, G-4, G-6, G-7, G-9-15, H-8, H-10, H-15, H-19, H-21, H-30, H-31, H-35
Example	1-1-2, 2-8, 6-4, 6-6, 7-9, 7-10, 7-12, 8-4, 8-5, 9-2, 10-5, 11-1, B-27, C-1, C-5, C-6, C-8, C-9, C-12, C-14, C-16, C-19, C-22, C-24, C-28, C-31, D-1, D-6, D-11-13, D-15, E-2, E-4, E-6, E-8, E-10, E-12, E-13, E-15, E-17-19, E-21, E-23-27, E-29, E-31, E-32, E-35, E-37-39, E-43, E-46, E-48, E-51, E-54, E-56, F-1, F-2, F-4, F-8, F-10, F-11, F-14, F-16, F-17, F-19, F-23, F-25, F-27, F-29, F-31, F-34, F-35, F-37, F-39, G-4, G-7, G-9-15, H-19, H-21, H-1-4, H-8-10, H-12, H-13, H-16, H-19, H-21, H-23, H-24, H-26, H-27, H-29, H-31, H-28, H-29, H-32-34, H-36
Execute	1-1, 1-2
Executive	2-1-1, 11-4
Exner Equation	7-12, B-2, B-5, B-16, B-29, B-36, H-6
Expansion	2-7, B-3, E-4, E-6, E-8, E-9
Extend Model	11-1, 11-4
failure	4-1, E-40
Files	1-1-1, 10-5, 10-6, C-1, C-2, H-14
.t12	1-1, 1-2, H-29-31
.t5	1-1, 1-2, H-8, H-28-31
.t6	1-1, 1-2, 11-1
.t98	1-1, 1-2, 10-1, 10-6
Attach	10-1, 10-6, H-14
Hot Start	H-8
Input	1-1-3, 2-2, 2-4, 4-1, 6-8, 7-9, 8-5, 8-6, 9-1, 9-2, 10-1, 10-3, 10-4, 11-1-4, 11-7, 11-9, B-7, B-8, B-10, B-11, B-14, B-15, B-17, B-18, B-22, B-29, B-33, B-37, B-38, C-41, C-1, C-2, C-8, D-1, D-3, D-7, D-10, D-17, E-1-4, E-6, E-8, E-10, E-12, E-13, E-15, E-23-25, E-27, E-29, E-31, E-32, E-34, E-35, E-37-39, E-43, E-46, E-48, E-51, E-54-57, F-1, F-2, F-4, F-6, F-8, F-10, F-11, F-14, F-16, F-17, F-19, F-23, F-25, F-27, F-28, F-30, F-41, G-3-8, G-10-13, G-16, H-19, H-21, H-1, H-2, H-6-10, H-12, H-14, H-16, H-19, H-23, H-24, H-31, H-28, H-32-36
Name	1-1, 1-2, 10-5, 10-6, 11-2, 11-8, B-5, B-7, B-10, B-20, B-29, F-1, F-2, F-17, F-18, H-8, H-35

FIND .....	1-3, 11-3
Fixed Bed .....	E-40, E-43, E-44, E-48, E-51
flow ...	2-2, 2-3, 2-5, 6-1-9, 7-1-4, 7-8, 7-10-12, 11-3, 11-4, B-2-5, B-8-10, B-12-14, B-22, B-24, B-26, B-27, B-30, B-33, C-1, C-6, C-16, C-17, C-26, D-6, D-7, D-11, D-15, D-16, E-25, E-26, E-32, E-33, F-16, F-34, F-39, G-4, G-6, G-7, H-1, H-2, H-7, H-12, H-23, H-30, H-32
Flow Direction .....	2-3, 6-1
Flow-through Time .....	7-2
Frame .....	10-5, 10-6
Plot .....	1-1, 1-2, 10-1-10, B-16, B-22, B-26, H-14, H-15, H-35
Friction .....	6-8
Front Water .....	6-2, 6-7
FS .....	C-8, C-10, C-11, C-15, C-20, C-22, C-29, D-8, F-17, F-19, F-22-24, F-31, F-33, F-34, F-36, F-37, H-24
GE-Record .....	E-37
Geometric Data ..	1-2, 2-2-4, 3-1, 4-2, 9-1, 11-5, 11-6, 11-9, B-15, B-27, B-29, B-31, C-2, C-5, D-1, D-7, D-15, E-1, E-3, E-17, H-3, H-4, H-17, H-31, H-28
Gradation ..	3-1, 7-2, 7-6, 7-12, B-35, B-36, B-38, C-3, C-4, C-8, C-10, C-12-15, C-17, C-20, C-22, C-26, C-29, D-1, D-8, D-9, F-2, F-8, F-25-28, F-39, H-9, H-30
Grain Size ...	2-3, 3-1, 7-3, B-1, B-7, B-10, B-12, B-13, B-16, B-17, B-22-24, B-29, B-34, B-35, C-3, F-9, F-11, F-13, F-17-20, F-22-24, F-26-28, F-30, F-33, F-34, F-36, G-5
Graphics .....	1-2, 6-8, 10-1, H-14
GR-Station .....	11-5, 11-6, B-26, E-48, E-49, E-51, E-52
Guidelines .....	F-8, F-11
Header .....	6-6, 10-5, 10-6, 10-8, 10-9
Heat .....	2-3, 4-2
Hot Start .....	H-8
Hydraulic .....	2-3, 2-7, 4-2, 6-1-3, 6-7-9, 8-5, 10-1, 10-2, 11-4, 11-5, B-7, B-10, B-29, B-34, B-36, C-2, D-3, D-10, D-15, E-8, E-12, E-29, E-34, E-35, F-14, F-15, F-29, G-4, H-15
depth ..	3-1-1, 6-7-9, 7-2-5, 8-4, 8-5, 9-1, 9-5, 10-2-11, B-13, B-22, B-25, B-27, B-28, B-32, B-35-37, D-10, D-15, E-8, E-10, E-11, E-13, E-14, E-17, E-18, E-20, E-21, E-29, E-39, E-40, E-42, E-43, E-45, E-48-51, E-53, F-12, F-29, H-4, H-7, H-14, H-23
Radius .....	6-7, B-34
Results ..	1-1, 2-8, 6-1, 6-6, 6-8, 7-5, 7-12, 10-4, B-10, C-5, D-3, D-16, E-8, E-17, E-19, E-20, E-39, G-13, H-6, H-10
Hydrograph .....	8-1, 8-5, 9-1, 10-3-4, B-13, D-4, F-19, F-20, F-32, F-35, F-37, F-39, G-12, H-8, H-31, H-32
Hydrologic Data ..	1-2, 4-1-3, 6-1, 6-8, 7-12, 8-1, 8-4, 10-1, 11-3, 11-4, 11-8, 11-9, B-13, C-2, C-4, C-6, D-3, E-12, E-24, F-41, G-3-8, G-10-13, G-16, H-1-4, H-14, H-16, H-19, H-29, H-32, H-35
Hyper-concentration .....	11-2
IDBSR_TEMPLATE .....	H-30
Inactive Layer .....	9-5, B-4-7, B-11, B-28, B-32, B-33, B-35-38, F-6, F-7
Inflow ..	2-2-4, 7-1, 7-2, 7-10, 7-12, 10-3, 10-4, 11-3-6, 11-9, 11-10, B-1, B-3, B-12, B-20, B-21, B-23-26, B-28-30, B-33, B-34, B-38, B-39, C-1, C-2, C-4-10, C-12, C-13, C-15, C-17, C-20, C-22, C-26, C-29, D-4, D-6, D-8, D-12-14, E-23-26, E-55, E-56, F-19, F-20, F-30-34, F-37, F-39, G-7, G-11, H-13, H-14, H-24-27, H-31, H-32
Initial .....	6-4, 8-1, 8-3-6, 10-5, B-3, B-6, B-14, B-15, B-28, B-29, B-35, B-37, D-1, D-8, F-1, F-5, F-25, G-5, H-2, H-15
bed gradation .....	3-1, B-36, B-38, C-3, C-4, C-8, C-10, C-12-15, C-17, C-20, C-22, C-26, C-29, D-8, F-2, F-25, F-39
conditions .....	2-3, 6-1-3, 7-1, 7-5, 7-10, 7-11, 8-4, 11-3, 11-7, B-27, C-6, D-3, E-36, F-1, F-25, H-23
Input Data Record .....	E-37
GE-Record .....	E-37
Input Data Records .....	B-15

\$\$END-Record	G-16, H-28
\$B-Record	H-1
\$CL-Record	2-2, 11-8, H-2
\$DREDGE -Record	H-3
\$EX-Record	H-6
\$GR-Record	8-1, H-7
\$HOT-Record	H-8
\$HYD-Record	C-5, D-1, G-3, G-8, H-28
\$K-Record	6-7, E-12
\$KI-Record	H-9
\$KL-Record	H-9
\$LOCAL-Record	E-55, F-31
\$MNMX-Record	H-10
\$OQC-Record	H-12
\$PLOT-Record	1-2, 6-8, 10-3, 10-4, H-14
\$PLOTP-Record	10-1
\$PRT-Record	H-16
\$RATING-Record	G-8, H-19
\$SCRT-Record	H-23
\$SED-Record	H-24
\$SEG-Record	8-4, C-2, C-3, E-2, E-55, H-17, H-29, H-30
\$SUBSID-Record	H-31
\$TAPE12-Record	H-28, H-29
\$TRIB-Record	2-2, E-55, E-56, F-31
\$UNET-Record	H-32
\$VOL-Record	H-33, H-34
\$WRITE-Record	H-35
\$WSCP-Record	2-2, 4-2, H-36
*-Record	1-1, 6-8, 7-12, 9-1, E-27, G-4-6, G-8, H-16
CP-Record	2-2, 3-1, 11-4, E-56, H-17
DC-Record	9-2, H-5
DF-Record	H-4
EJ-Record	E-54
END-Record	G-16, H-24
GE-Record	E-37
GR-Record	8-1, 11-6, E-38, H-7
H-Record	11-6, E-28, E-39, E-43, H-4
HD-Record	E-39, E-43, E-48, E-51
HE-Record	2-4, E-35, E-43, E-46, E-48, E-51, H-31, H-29
HI-Record	E-39, E-48
HL-Record	9-1, E-39, E-43, E-48, E-51, H-29
I1-Record	F-2
I2-Record	11-7, F-4, F-6, F-10
I3-Record	11-2, F-6, F-8
I4-Record	7-10-12, 11-2, D-1, F-11
I5-Record	6-8, 10-2, F-14
I6-Record	7-11, 11-2, F-16
IX-Record	11-7, F-7, F-10
J-Record	F-17

K-Record	3-1, 6-7, E-12, F-17, H-9
LC-Record	F-20
LCL-Record	F-30, F-32, F-35, F-38
LF-Record	C-4, F-22, H-24, H-28
LFL-Record	F-30, F-33, F-36, F-38, F-40
LP-Record	11-8, 11-9, H-24, H-25
LQ-Record	F-19-24
LQL-Record	F-30-32, F-34-40
LR-Record	H-24, H-26
LRATIO-Record	H-27
LT-Record	F-19, F-20
LTL-Record	F-30, F-32, F-36, F-40
N-Record	E-12, F-25, F-26
NC-Record	E-3, E-4, E-6, E-8, E-18, E-19
ND-Record	E-10, E-11, E-17, E-18, E-20
NH-Record	11-6
NK-Record	E-12
NM-Record	E-13, E-14
NV-Record	E-10, E-15, E-16, E-18, E-19, E-21
OC-Record	11-8
OF-Record	F-28
P-Record	6-5, C-8, D-6, D-8, D-10-13, E-4, E-6
PF-Record	F-25, F-27, F-28
PN-Record	H-17, H-18
PS-Record	H-17, H-18
PX-Record	11-1, E-5, E-6
Q-Record	11-7, E-24, E-56, G-4, G-7-9, G-11, H-32
QL-Record	11-5, 11-6, E-25, F-39
QP-Record	11-6, E-23, E-25, E-26, F-30
QT-Record	2-2, E-23, E-24
R-Record	4-2, G-8, G-9, H-19, H-36
S-Record	4-3, G-8, G-10
SD-Record	C-3, F-23, F-24
T-Record	G-11
T1-Record	1-3, E-3
T3-Record	E-4
T4-Record	F-1, F-2, F-4, H-31
VJ-Record	H-21, H-22, H-33
VR-Record	H-34
W-Record	G-12, G-13
X-Record	11-8, 11-9, G-13
X1-Record	8-5, E-1, E-8, E-23, E-24, E-27, E-32, E-35, E-46, F-27
X3-Record	E-32, H-20
X5-Record	2-3-5, B-30, E-34, G-8, G-9
XB-Record	11-3, E-29, E-31
XC-Record	E-29, E-31
XL-Record	11-2, 11-6, E-35, H-19, H-20
Installation	1-1
Internal Boundary Condition	B-13

invert .....	E-5, E-7, H-30
Island Flow .....	2-2, 6-7, 11-3, B-22, B-24, B-33, C-1, C-16, C-17, C-26
ISMOPT .....	H-30
Iterations .....	1-2, 11-4, B-24, D-14, F-2
junction .....	2-2-5, 5-1, 6-4, 11-6, B-1, B-19, B-23, B-33, B-34, C-1-6, C-12, C-13, C-19, C-20, D-3, E-24, F-23, F-24, H-2
Keyboard .....	10-6
Layer ...	7-2, 7-5, 7-6, 7-11, 7-12, 9-3, 9-5, 11-2, 11-7, B-1, B-4-11, B-22, B-28, B-32-38, D-8, F-2, F-6, F-7, F-10, F-25, F-28, F-29
active layer .....	7-2, 7-5, 7-6, 7-11, 7-12, 9-5, B-1, B-5-9, B-11, B-32, B-35, B-37, B-38, F-6, F-7, F-28, F-29
cover layer .....	B-10, B-11
depth of ...	9-5, 10-2, B-5-9, B-22, B-32, B-37, E-39, E-40, E-42, E-43, E-45, E-48, E-49, E-51, E-53, F-29, H-4, H-7
inactive layer .....	9-5, B-4-7, B-11, B-28, B-32, B-33, B-35-38, F-6, F-7
surface layer .....	B-4, F-2
Thickness .....	7-5, B-4
LB .....	B-21, F-5, F-6, F-9, F-13
Legend .....	10-5, 10-6
Limerinos .....	6-7, E-12, E-29, H-9
LIST .....	1-2, 10-5
Local Inflow .....	2-3, 4-1-6, B-1, B-20, B-23-26, B-29, B-30, B-33, B-34, B-38, B-39, C-1, C-2, C-4-6, C-9, C-10, C-20, D-6, E-23-26, E-55, F-30-34, F-37, F-39, G-7, H-24-27, H-31, H-32
LSMO .....	H-30
MAGO .....	11-1, B-25
Main Channel .....	3-1, 4-1, B-4, C-5, D-15, F-34, H-24
Manning .....	10-2, B-14, E-8, E-29
Maximum ...	7-3, 7-7, 7-11, 10-4, 11-8, B-1, B-2, B-5-7, B-23, B-25, B-26, B-28, B-36, D-6, E-18, E-21, E-38, F-16, F-20-22, F-24, F-26, F-28, F-35, F-38, F-40, H-10, H-11, H-20
Mbh-plotter .....	10-5
Meander .....	E-8
Measurement .....	2-3
Menu .....	10-5, 10-6
Movable Bed .....	2-4, 2-8, 8-1, 8-3, 8-4, 11-2-3, B-11, E-28, E-40, E-41, E-43, E-44, E-46, E-48, E-49, E-51, E-52, H-29
MS .....	ii, C-8, C-10, C-11, C-22, C-29, D-8, F-17, F-19, F-23, F-31, F-34, F-37, H-24
Mudflow .....	7-5
NETCP .....	2-5
Network .	2-1-3, 4-1, 4-3, 6-1-4, 7-1, 7-12, 11-6, B-15, B-19, B-22, B-24-26, B-28-31, B-33, B-35, B-36, B-38, C-1-6, C-8, D-3, D-7, D-10, D-12, E-2, E-3, E-25, E-55, E-56, F-1, F-27, F-29, F-39, G-4, G-7, G-9-15, H-13, H-17, H-21, H-32, H-36
Network Schematic .....	4-1
NEVNT .....	6-6, B-28
NEWGR .....	B-1, B-8
NGDS .....	2-5, 11-8, 11-9, B-13, B-16, B-19, B-23, B-29, B-30, B-33, E-2, E-56, H-17, H-25-27
Node .....	5-1, B-19, B-30
NOGO .....	1-3, 11-1, B-30
Non-cohesive .....	7-5, 7-6, B-26, B-32, B-33, B-37, F-4
Normal Depth .....	6-1, 6-8, B-13, H-23
NWSCP .....	4-2
NWSP .....	6-6, B-31
NXS .....	11-8, B-32, F-7

n-value	6-7-9, 10-2, 11-5, B-3, B-4, B-27, B-29, D-1, D-15, E-8, E-10, E-11, E-15-21, E-29, F-17, F-18, H-14
Operating Rule	2-3, 2-4, 4-1, B-16, B-24, E-34
Organization	ii, 1-1, 1-2
Original	2-2, 2-3, 2-8, 3-1, 6-7, 7-1, 7-5, 9-6, B-12, B-14, B-36, E-4, E-39, F-3, F-4, F-8, F-15, F-16, H-6, H-7, H-24, H-28
Outflow	2-2-4, 4-1-3, 7-2, 7-12, 11-3, 11-5, 11-6, 11-8, 11-9, B-1, B-12, B-21, B-23, B-25, B-29, B-30, B-33, B-34, B-38, B-39, C-5, C-28, C-29, D-4, D-12, E-23-26, F-30, F-34-37, F-39, G-7, H-1, H-13, H-24, H-25, H-31
Outlets	6-2, 6-3, 6-6
Output	1-1-3, 6-8, 10-1, B-10, B-19, D-4, D-15, F-1, G-4, G-5, H-14, H-16-18
Overbank	D-6, D-7, D-15, E-7, E-8, E-10, E-12, E-15, E-18-20, E-27, E-28, E-31, E-33, H-21, H-9, H-34
Particle Size	2-3, 4-1-3, 7-7, B-1-3, B-5, B-12, B-33, B-34, D-1, D-4, F-28, G-11
Path	10-5
Perimeter	6-8, B-4, B-9, B-20, B-37, E-17, E-18, E-20, G-4
Pier	2-8
Plot	1-1, 1-2, 10-1-10, B-16, B-22, B-26, H-14, H-15, H-35
Plot Sort	10-1
ppm	7-5, F-20
Print	1-2, 1-3, 7-11, 7-12, 10-6, B-15, C-4, E-56, F-1, G-4, G-6, H-16, H-17
Printout	1-1-3, 6-8, 6-9, 7-12, 8-4-6, 10-1-3, B-2, B-10, B-16, B-18, B-21, B-24, C-2, C-4, C-5, C-31, D-1, D-3, D-4, D-6, D-15, D-16, E-3, F-1, G-4-7, H-20, H-3, H-16-18, H-22, H-26, H-33
A-Level	6-8, 6-9, C-2, C-4, D-3, D-4, D-15, D-16, G-6
B-Level	6-8, 6-9, 10-2, B-16, D-3, D-4, D-15, H-16
C-Level	1-3, 8-4, E-3
Trace	8-4, B-18, E-3-5, H-20, H-3, H-33, H-35
Profile	1-1, 6-5, 6-6, 6-8, 10-1-5, B-31, B-38, D-3, D-4, D-12, D-16, E-4, E-38, H-19, H-21, H-4, H-15, H-23
Bed	2-4, 2-8, 3-1, 6-7, 6-9, 7-1-5, 7-9-12, 8-1, 8-3-6, 9-1, 9-3, 10-2-5, 10-10, 11-2, 11-3, 11-6, B-2-12, B-15, B-19, B-22, B-26, B-28-30, B-34-38, C-3, C-4, C-8, C-10, C-12-15, C-17, C-20, C-22, C-26, C-29, D-1, D-3, D-4, D-8-13, D-15, D-16, E-10, E-12, E-15, E-18, E-28, E-29, E-35, E-39-46, E-48-53, F-2, F-3, F-5, F-6, F-8, F-9, F-12, F-13, F-25-28, F-39, G-4, G-5, H-3, H-6, H-9-11, H-14, H-15, H-29, H-30, H-29, H-30, H-33
Bed Surface	10-2, 10-4, 10-5, 10-10, B-4, B-7, B-34, B-35, F-28, G-5, H-11, H-30
Plot	1-1, 1-2, 10-1-10, B-16, B-22, B-26, H-14, H-15, H-35
Printout	1-1-3, 6-8, 6-9, 7-12, 8-4-6, 10-1-3, B-2, B-10, B-16, B-18, B-21, B-24, C-2, C-4, C-5, C-31, D-1, D-3, D-4, D-6, D-15, D-16, E-3, F-1, G-4-7, H-20, H-3, H-16-18, H-22, H-26, H-33
Water Surface	1-1, 2-3, 2-4, 2-8, 4-2, 4-3, 6-1, 6-2, 6-5-9, 8-5, 10-1-5, 10-10, 11-4, B-1, B-4, B-5, B-8, B-15, B-19, B-29, B-31, B-38, C-6, D-3, D-4, D-15, D-16, E-4, E-6, E-32, E-34, E-40, E-43, E-44, G-4, G-5, G-8-10, H-19, H-21, H-2, H-4, H-10, H-11, H-20, H-34, H-36
Program Commands	1-2, 2-1, 2-2, 6-1, 6-8, 10-1, 11-4, 11-8, 11-9
QICP	6-5
QTOTAL	6-4, 6-5, 11-4
rate of	7-2, 7-5, 7-10, B-3, B-8, F-6, H-31
Rating Curve	4-2, 4-3, B-18, B-35, F-19, F-31, G-8, H-19, H-20, H-24, H-31
Rating Shift	G-10
Reach	2-2-3, 6-7, 6-9, 7-1-4, 7-12, 8-1-3, 9-6, 11-1, 11-4, 11-5, B-2, B-4-7, B-9-12, B-15, B-20, B-23, B-24, B-27, B-29-32, B-34, B-35, C-5, D-1, D-8, D-13, D-15, E-1, E-7, E-8, E-17, E-27-29, E-31, E-34, F-10, H-20, H-1, H-3, H-5
length	2-2, 2-4, 4-1, 7-2, 7-4, 9-1, 9-3, 11-1, 11-4, 11-5, B-4, B-6, B-9-11, B-22, B-28, B-34, B-35, D-9, D-10, E-1, E-6, E-7, E-27-29, E-31, E-34, G-12
n-value	6-7-9, 10-2, 11-5, B-3, B-4, B-27, B-29, D-1, D-15, E-8, E-10, E-11, E-15-21, E-29, F-17, F-18, H-14
properties	6-7, 7-9, 9-1-4, E-6, E-8, E-10, E-12, E-13, E-15, E-18, E-23-25, E-27, E-29, E-31, E-32, E-34, E-35, E-37-39, E-43, E-46, E-48, E-51, E-54-56, F-1, F-2, F-4, F-6, F-8, F-10, F-11, F-14-17, F-19, F-23, F-25, F-27, F-28, F-30, F-39, H-19

Reservoir	2-4, 6-1, 7-2, 7-12, 8-1, 10-3, 10-4, 11-2, 11-6, B-3, B-6, B-11, B-28, B-34, B-36, B-37, D-1, D-9, E-39, E-40, E-42-45, E-48-51, E-53, F-27, H-6, H-30, H-29, H-30
Reset	11-4
Residence	7-12, D-4
Residual	B-7, B-11, B-34, B-36, B-38
Restart	11-8, E-40, E-44, E-49, E-52, H-17, H-35
Restricted	2-4, 8-4, E-35
Resume	4-2-4, H-8, H-35
Return Flow	E-25, E-26, F-39
Reuse	10-6, B-6, E-37
Re-circulation	H-22
River Mechanics	A-1
Roadway	2-8
Robust	6-1
roughness	3-1, 6-7, E-8, E-12, E-18, E-27, E-29, H-9
Roughness, Bed	
Brownlie	6-7, E-12, E-29, F-13, H-9
Limerinos	6-7, E-12, E-29, H-9
Manning	10-2, B-14, E-8, E-29
Routing	5-1, E-25
Sand	7-6, 7-7, 7-9-12, 8-4, 10-2, 10-4, B-2, B-6, B-12, B-15, B-16, B-21, B-22, B-24, B-26, B-30, B-33, B-35-38, D-4, D-8, D-12-14, E-12, F-8, F-11, F-13, F-35, G-5, H-14, H-29
SB-2	8-5, 10-1, 10-2, D-4, D-12, H-16
Schematic	2-1, 2-2, 4-1
Scope	1-1, 7-2
Scour	2-8, 7-4, A-1, B-5, B-6, B-35, E-40, E-43, F-8, F-25
Screen	1-1, 10-5-10
Scroll	1-1
Search	C-2, D-1
Section	1-2, 1-3, 2-2-4, 2-7, 2-8, 4-1, 4-2, 6-1-3, 6-7-9, 7-1, 7-11, 7-12, 8-1-6, 9-1, 9-3-6, 10-1-4, 11-2-6, 11-9, B-1-12, B-14-24, B-27-38, C-4-6, D-1, D-3, D-4, D-6, D-8, D-10-13, D-15, D-16, E-1, E-3-8, E-16-19, E-21, E-23, E-24, E-27, E-28, E-30, E-32-46, E-48-55, F-2, F-3, F-5-7, F-10, F-14, F-15, F-17, F-25-29, G-4, G-5, G-11, G-12, H-19-21, H-1, H-3-5, H-7, H-9-11, H-14, H-16-18, H-21-23, H-29, H-31-34
Sediment Delivery	D-4, D-13
Sediment Load	7-3, 7-10, 10-4, 11-3, B-14, B-16, B-33, D-1, D-4, D-12, F-2, F-12, F-19-23, F-30, F-32, F-38, G-5, H-21, H-24-28
Sediment Mixture	7-6, 7-11, 11-2, F-16
Sedimentary Data	1-2, 1-3, 11-7, C-3, C-6, D-1, D-3, D-8, E-26, E-56, E-57, F-1, F-10, H-21
Sedimentation	i, 2-3, 6-1-3, 6-9, 8-1, 8-6, 10-2, 10-5, C-2, C-6, D-3, D-4, D-6, D-15, F-3, H-16
compaction	B-3-5, F-9
deposition	2-4, 2-8, 3-3, 7-2-5, 8-1, 9-6, 10-4, 11-2, 11-7, B-1, B-2, B-5-8, B-25, B-27, B-36, E-35, E-40, E-43, E-46, F-3-9, H-7
entrainment	7-2, 7-3, 7-5, 7-11, B-9
erosion	2-4, 7-4, 7-5, 8-1, 10-3, 10-4, 11-2, 11-7, B-1, B-2, B-8, B-14, B-34, E-28, E-35, E-39, E-46, F-3, F-4, F-6-8, F-28, H-7, H-29
transportation	3-1, 7-3-7, B-4, B-9-14, B-25, B-27, B-28, B-31, B-34, B-36, D-8, F-1, F-2, F-4, F-6, F-8, F-10-14, F-16-19, F-23, F-25, F-27, F-28, F-30
Sedimentation Processes	7-1, 8-1, G-12
Segment	2-2, 2-4, 4-1-3, 5-1, 6-2, 6-4, 6-6, 7-1, 7-12, 9-1, 9-6, 11-3-6, 11-8, 11-9, B-1, B-2, B-6, B-9, B-10, B-12-14, B-16,

	B-17, B-19, B-21-33, B-35, B-36, C-1-8, C-12-17, C-19, C-20, C-24-26, D-1, D-3, D-4, D-6-8, D-10-13, D-15, E-1-5, E-23, E-25, E-26, E-34, E-54, E-56, F-1, F-7, F-10, F-25, F-27, F-30, F-39, G-5-7, G-9, G-11, H-2, H-13, H-17, H-21, H-25-27
Network . . .	2-1-3, 4-1, 4-3, 6-1-4, 7-1, 7-12, 11-6, B-15, B-19, B-22, B-24-26, B-28-31, B-33, B-35, B-36, B-38, C-1-6, C-8, D-3, D-7, D-10, D-12, E-2, E-3, E-25, E-55, E-56, F-1, F-27, F-29, F-39, G-4, G-7, G-9-15, H-13, H-17, H-21, H-32, H-36
Segment Number	1-1-4, 2-7, 4-2, 5-1, 6-2, 6-4-6, 7-1, 8-3, 9-1, 9-2, 9-6, 11-1-6, 11-8, 11-9, B-2, B-4, B-9, B-11, B-13-34, B-36, B-38, C-3, C-5, C-6, C-8, D-1, D-6-8, D-12, D-15, E-2, E-3, E-5, E-7, E-10, E-12, E-13, E-15-21, E-26, E-27, E-30, E-33, E-36, E-37, E-40, E-43, E-46, E-48, E-49, E-51, E-52, E-56, F-1-3, F-6-11, F-13, F-16, F-24, F-25, F-27, F-28, F-31, F-35, G-13-15, H-21, H-2, H-5, H-13, H-17-20, H-22, H-24-27, H-30, H-32, H-34, H-36
selective . . . . .	B-16, H-16-18
Sequence . . .	1-2, 1-3, 2-2, 2-3, 7-1, 8-3, B-12, B-16, B-19, B-23, B-28, B-30, B-32, D-15, F-1, F-4, F-24, F-30, G-7, G-9, H-17, H-18, H-22, H-32
Settling Velocity . . . . .	7-2-5, B-10, G-11
Shape Factor . . . . .	B-3, B-12, B-31, F-13
Shear Stress . . . . .	6-7, 7-3-5, 11-2, 11-7, B-36, F-3, F-5, F-6, F-9
Shell . . . . .	1-1, 1-2
Silt . . .	7-2-4, 7-6, 7-7, 7-9, 7-12, 10-2-4, B-2, B-7, B-12, B-15-17, B-21, B-22, B-24, B-26, B-30, B-32, B-33, B-35, B-37, B-38, D-4, D-13, F-1, F-3, F-4, F-6, F-8-11, F-27, G-5, H-14
Simulation . . . . .	1-2, 7-2, 7-11, 7-12, 8-3-6, 10-1, F-9, H-24, H-29
Single Event . . . . .	G-13
Slope . . .	3-1, 6-7-9, 8-1, 8-3, 8-4, 10-2, 11-3, B-1, B-3, B-7, B-11, B-27, B-35, B-36, C-4, C-12, C-19, D-7, D-15, E-4, E-5, E-7, F-6, F-12, F-15, H-21, H-23, H-29, H-34
bank . . . . .	2-3, 4-1, 6-7, 11-5, C-22, E-3, E-10, E-15, E-27, E-29-32, E-35, H-9, H-14, H-29, H-30
bed . . . . .	2-4, 2-8, 3-1, 6-7, 6-9, 7-1-5, 7-9-12, 8-1, 8-3-6, 9-1, 9-3, 10-2-5, 10-10, 11-2, 11-3, 11-6, B-2-12, B-15, B-19, B-22, B-26, B-28-30, B-34-38, C-3, C-4, C-8, C-10, C-12-15, C-17, C-20, C-22, C-26, C-29, D-1, D-3, D-4, D-8-13, D-15, D-16, E-10, E-12, E-15, E-18, E-28, E-29, E-35, E-39-46, E-48-53, F-2, F-3, F-5, F-6, F-8, F-9, F-12, F-13, F-25-28, F-39, G-4, G-5, H-3, H-6, H-9-11, H-14, H-15, H-29, H-30, H-29, H-30, H-33
bottom . . .	2-8, 9-1, 9-5, B-2, B-7, B-9, B-12, B-14, B-15, B-17, B-23, B-38-45, E-49, E-50, E-52, E-53, F-2, H-4, H-29, H-30
critical . . . . .	7-4, B-4, C-6, F-2, H-23
failure . . . . .	4-1, E-40
stable . . . . .	8-4, B-10, H-29
Smoothing . . . . .	8-1, 8-3-5, H-29, H-30
Special Bridge Routine . . . . .	2-8
Specific Gravity . . . . .	7-6, 7-7, 7-9-12, B-35, B-36, F-3, F-5, F-9, F-13
Specific Weight . . . . .	7-6, 7-9-11, 9-3, 11-2, B-8, B-33, B-37
Stability . . . . .	7-5, 8-1
Stable . . . . .	8-4, B-10, H-29
Stable Slope . . . . .	H-29
Stage . . . . .	2-1, 4-1, 4-2, B-13, B-14, B-18, B-25, B-34, B-35, H-20
Stage-discharge . . . . .	2-1, 4-1, 4-2, B-35, H-20
Start Station . . . . .	E-35, E-36
Station . . .	2-8, 8-3, 8-4, 9-1, 9-5, 10-1-4, 11-2, 11-5, 11-6, B-4, B-9, B-17, B-18, B-21, B-26, B-36, B-37, C-20, E-18, E-19, E-21, E-27-30, E-33, E-35-38, E-40-46, E-48, E-49, E-51, E-52, F-7, F-10, H-19, H-18
bank . . . . .	2-3, 4-1, 6-7, 11-5, C-22, E-3, E-10, E-15, E-27, E-29-32, E-35, H-9, H-14, H-29, H-30
channel . . .	2-3, 2-8, 6-7-9, 8-1, 8-5, 8-6, 9-1, 9-5, 10-1-4, 11-3, 11-5, 11-6, A-1, B-2, B-4, B-7, B-8, B-14, B-22, B-33, B-38, C-2, C-5, C-6, D-15, E-2-4, E-6-8, E-10, E-12, E-13, E-15, E-18-20, E-23-25, E-27-46, E-48,

	E-49, E-51, E-52, E-54-56, F-7, F-10, F-34, F-39, H-21, H-7, H-9, H-18, H-24, H-30, H-31, H-34
GR-Station	11-5, 11-6, B-26, E-48, E-49, E-51, E-52
Status	11-1, D-12
Stop	5-1, 9-5, 11-3, 11-6, B-15, E-36, E-45, E-49, E-52, H-3
Storage	11-8, B-2-4, B-6, B-8-11, B-13, B-14, B-17, B-18, B-21, B-23, B-26, B-33-36, B-38, B-39, E-35, H-19-22, H-33
straight	6-5, B-2, B-10, B-38, F-28
Stream	i, 2-1, 2-2, 6-4, 6-6, 8-1, 11-5, B-19, B-22, B-24, B-28-31, C-1, C-2, C-5, D-6, D-10, E-3, E-54-56, F-1, F-7, F-9, F-12, F-27, F-30, H-17, H-21, H-25
STREDI	11-2, 11-7
Stress	6-7, 7-3-5, 11-2, 11-7, B-36, F-3, F-5, F-6, F-9, H-14
bed shear	6-7, 7-3-5, B-36, F-3, F-5, F-6, F-9
critical	7-4, B-4, C-6, F-2, H-23
Strip	1-3, 6-7, 6-9, 11-2, 11-5, B-9, B-14, B-17, B-22, B-24, B-29, B-30, D-15, E-10, E-12, E-15, E-17-21, E-29, H-9
STST	11-2, 11-6, B-9, B-17, B-18, B-21, B-36, B-37, E-36, H-19, H-20
Subcritical flow	6-1, C-6
Subfiles	1-2
Subject	8-1, 11-1, B-34
Subroutine	2-1, 4-1-3, 7-2, 7-6, 7-12, 8-4, 11-7, B-1, B-8, B-9, B-11, B-13-15, B-20, B-36, B-37
PRSELX	11-4
READDB	4-2
READEX	11-9
READGR	11-6
READHR	11-6
READIX	11-7
READMB	11-2, 11-3, 11-6
READN	11-7
READQL	11-6
READSC	11-4, 11-9
READSD	11-7
READUQ	11-9
Subsection	2-8, 6-8, 10-2, 10-3, 11-5, B-16-18, B-22, B-31, B-33, B-34, E-8, E-10, E-13, E-15, E-16, E-18, E-28, E-29, E-31, G-4, H-21, H-34
Subsection Station	B-18
Supercritical	6-1, 6-8, B-13, H-1, H-23
Surface	1-1, 2-3, 2-4, 2-8, 4-2, 4-3, 6-1, 6-2, 6-5-9, 7-1, 7-4, 7-12, 8-5, 10-1-5, 10-10, 11-4, 11-10, B-1, B-4, B-5, B-7, B-8, B-10, B-15, B-19, B-24, B-29, B-31, B-34, B-35, B-38, C-6, D-3, D-4, D-11, D-15, D-16, E-4, E-6, E-32, E-34, E-40, E-43, E-44, F-2, F-13, F-25, F-28, G-4, G-5, G-8-10, H-19-22, H-2, H-4, H-10, H-11, H-14, H-20, H-30, H-34, H-36
area	2-2, 6-7, 7-1, 7-4, 7-11, 8-1, 8-5, 8-6, 10-3, 11-10, B-1, B-4, B-5, B-7, B-8, B-20, B-23, B-24, B-27-29, B-34, B-35, D-6, D-7, E-28, E-32, E-33, F-7, F-13, F-25, G-4, H-19-22, H-3, H-14, H-30, H-34
bed	2-4, 2-8, 3-1, 6-7, 6-9, 7-1-5, 7-9-12, 8-1, 8-3-6, 9-1, 9-3, 10-2-5, 10-10, 11-2, 11-3, 11-6, B-2-12, B-15, B-19, B-22, B-26, B-28-30, B-34-38, C-3, C-4, C-8, C-10, C-12-15, C-17, C-20, C-22, C-26, C-29, D-1, D-3, D-4, D-8-13, D-15, D-16, E-10, E-12, E-15, E-18, E-28, E-29, E-35, E-39-46, E-48-53, F-2, F-3, F-5, F-6, F-8, F-9, F-12, F-13, F-25-28, F-39, G-4, G-5, H-3, H-6, H-9-11, H-14, H-15, H-29, H-30, H-29, H-30, H-33
roughness	3-1, 6-7, E-8, E-12, E-18, E-27, E-29, H-9
water	1-1-4, 2-8, 4-1-3, 6-1-9, 7-1, 7-2, 7-4-7, 7-9-12, 8-5, 9-1, 9-6, 10-1-5, 10-10, 11-4, 11-8, 11-9, B-4-10, B-13-15, B-19, B-24-26, B-28, B-29, B-31, B-33, B-34, B-37, B-38, C-2, C-4-7, D-3, D-4, D-10-12, D-15, D-16, E-4, E-6, E-8, E-13, E-23-26, E-32, E-34-36, E-40, E-43, E-44, F-3, F-8, F-12, F-16, F-19-24, F-29-32, F-34-40, G-4, G-5, G-7-12, H-19, H-21, H-2, H-4, H-5, H-10-14, H-20, H-24, H-32, H-34, H-36

Suspended sediment .....	3-3, 7-3, 11-2, B-6
Sweep .....	5-1, 6-1-3, 7-1, 7-12, 8-3, 8-4
Backward .....	4-1, 8-3, 8-4, B-30
Two-sweep .....	6-1, 7-12
System .....	6-3, 7-7, B-27
Table .. i, 2-1, 2-3-5, 6-2, 6-3, 6-9, 7-10, 8-5, 9-1, 9-2, 10-1-4, 11-1, 11-2, 11-8, B-4, B-13-16, B-23, B-24, B-26-28, B-30, B-33, B-34, C-2-6, C-8, D-1, D-3, D-4, D-6-16, E-10, E-13, E-15-21, E-26, F-8, F-9, F-11, F-13, F-16, F-19, F-20, F-23, F-24, F-30-32, F-34, F-37, F-39, G-5-7, H-21, H-22, H-14, H-16, H-20, H-24-28, H-33, H-34	
Tailwater .....	4-1, E-34, H-19, H-21, H-31, H-32, H-36
Tape98 .....	1-1, 10-5
Temperature .....	4-2, 7-2, 11-8, B-19, B-38, C-4, C-7, D-3, D-10, D-11, G-4, G-11
Template .....	8-1, 9-1, E-6, E-28, E-39, E-41, E-43, E-45, E-48, E-49, E-51, H-5, H-30, H-31
Cross Section ..	1-2, 1-3, 2-2-4, 2-7, 2-8, 4-1, 4-2, 6-1-3, 6-7-9, 7-1, 7-11, 7-12, 8-1-6, 9-1, 9-3, 9-5, 9-6, 10-1-4, 11-2-6, 11-9, B-1-12, B-14-16, B-18-24, B-27-38, C-4, C-6, D-1, D-3, D-4, D-6, D-8, D-11, D-15, D-16, E-1, E-3-8, E-16-19, E-21, E-23, E-24, E-27, E-28, E-30, E-32-46, E-48-53, F-2, F-7, F-10, F-14, F-15, F-25-29, G-4, G-5, H-19-21, H-3-5, H-7, H-10, H-11, H-16-18, H-21-23, H-29, H-31-34
Dredging ...	9-1-3, 9-5, 9-6, 11-4, 11-6, B-5-8, B-14-16, B-25, B-27-29, B-32, B-35, C-24, E-28, E-39, E-41-45, E-48-53, H-3-5
P-Record .....	6-5, C-8, D-6, D-8, D-10-13, E-4, E-6
PX-Record .....	11-1, E-5, E-6
Thalweg .....	7-12, 10-2, D-4, D-9, D-12, E-40, G-5
Threshold .....	7-11, 11-2, B-7, B-36, F-5, F-6, F-9
Time ..	4-1-5, 7-11, 7-12, 8-1, 8-3-6, 10-2, 10-6, 11-8, B-1, B-5, B-7-12, B-27, B-29, B-32, B-34, B-35, B-37, D-4, D-12, E-34, E-55, F-2, F-4, F-5, F-9, F-13, G-4, G-5, G-8-15, H-3, H-4, H-6, H-7, H-23, H-25, H-29-31
Computation ...	5-1, 6-2, 7-4, 7-12, 8-4, 10-1, 11-8, B-2, B-5, B-7-9, B-11, B-12, B-32-34, B-37, B-38, E-5, E-7, E-34, F-2, F-3, G-12-15, H-21, H-7, H-23, H-34
Interval .....	7-4, 8-4, 8-5, B-8, B-12, D-8, F-5, F-27, G-12, G-13, H-20, H-30
W-Record .....	G-12, G-13
X-Record .....	11-8, 11-9, G-13
Title .....	1-1, 1-3, 10-5, B-10, B-31, B-32, C-4, C-23, D-1, D-3, D-4, E-3, F-1, G-4, G-5, H-14, H-15, H-35
Transport ...	3-1, 7-3-7, B-4, B-9-14, B-25, B-27, B-28, B-31, B-34, B-36, D-8, F-1, F-2, F-4, F-6, F-8, F-10-14, F-16-19, F-23, F-25, F-27, F-28, F-30
Transport Function .....	3-1-4, B-11, B-13, B-27, B-28, B-31, B-34, D-8, F-12, F-17, F-18
Trap Efficiency .....	2-4, 7-12, 10-3, 10-4, B-21, B-27, G-5
Tree Branch Network .....	C-1
Trial .....	6-5, 11-3, B-1, B-4-6, B-8, B-10, B-15, E-4, E-6, G-4
Tributary .....	2-2, B-1, B-19, B-24, B-29, B-31, B-33, B-34, C-2, C-5, E-23, E-24, E-55, H-24
Two-step .....	8-3
Type .....	1-3, 2-3, 2-4, 2-8, 2-9, 5-1, 9-2, 11-1, 11-2, 11-7, B-14, B-19, B-23, B-30, C-5-7, E-17-21, E-36, F-6, F-7, F-10, H-5
UNET .....	11-9, B-14, H-32
Uniform .....	3-3, 8-1, H-7
Updated .....	6-5, H-28
Upstream	2-2, 2-3, 6-1, 6-2, 6-4, 6-5, 6-7, 7-1, 7-12, 10-3, 10-4, B-2, B-6, B-9, B-12, B-13, B-16, B-29, B-31, B-33, B-34, C-2, C-4-6, C-8, D-4, D-7, E-1, E-2, E-19, E-23, E-24, E-34, F-7, F-10, F-14, F-15, F-25, F-27, G-7, G-11, H-1-3, H-17, H-26, H-32
User .....	i, 3-1, 3-2, B-11, B-27, B-31, E-39, F-1, F-7, F-10, F-12, F-14, F-17, F-18, G-4, G-8, G-10, H-7, H-24, H-30
VCS .....	C-9-11, C-22, C-29, D-8, F-19, F-23, F-31, F-34, F-35, F-37, H-24
Velocity .....	3-3, 6-1, 6-7-9, 7-2-4, 10-2, B-5, B-6, B-10, B-17, B-24, B-30, B-31, B-35, D-11, D-15-17, E-19, E-20, E-29, F-3, G-4, G-11, H-9, H-14, H-23

Velocity Head .....	B-6, G-4
Version .....	2-2, 2-4, 2-8, 6-3, 7-1, 7-5, 7-11, 11-9, B-5, B-11-15, B-24, B-27, B-30, B-36, C-2-6, C-8, C-9, C-12, C-14, C-16, C-17, C-19, C-24-26, C-28, D-1, D-6, D-11, E-2, E-8, E-10, E-12, E-55, E-56, F-16, F-31, H-6, H-17, H-23, H-25
Vertical .....	8-4, E-32, E-33
VFS .....	C-8, C-10, C-15, C-20, C-22, C-29, D-8, F-17, F-19, F-22-24, F-31, F-33, F-34, F-36, F-37, H-24
Volume .....	2-3-4, 7-6, 7-7, 7-9-12, 10-3-5, B-1-3, B-6-8, B-10, B-13, B-18, B-19, B-22, B-24, B-27, B-29, B-31, B-32, B-34, B-37, F-16, G-5, H-19-22, H-3, H-14, H-33, H-34
WAL .....	B-37
Warning .....	2-2, 7-11, 11-1, B-25, F-4
Water ...	1-1-4, 2-8, 4-1-3, 6-1-9, 7-1, 7-2, 7-4-7, 7-9-12, 8-5, 9-1, 9-6, 10-1-5, 10-10, 11-4, 11-8, 11-9, B-4-10, B-13-15, B-19, B-24-26, B-28, B-29, B-31, B-33, B-34, B-37, B-38, C-2, C-4-7, D-3, D-4, D-10-12, D-15, D-16, E-4, E-6, E-8, E-13, E-23-26, E-32, E-34-36, E-40, E-43, E-44, F-3, F-8, F-12, F-16, F-19-24, F-29-32, F-34-40, G-4, G-5, G-7-12, H-19, H-21, H-2, H-4, H-5, H-10-14, H-20, H-24, H-32, H-34, H-36
Wave .....	6-1, 11-4, 11-9
Weight ..	6-8, 7-2, 7-4, 7-6, 7-7, 7-9-11, 10-3, 10-4, 11-2, B-1-3, B-5, B-7, B-8, B-10-12, B-33, B-34, B-36-38, D-4, D-14, F-3, F-5, F-9, F-13, F-29, H-33
WES .....	2-2, 2-4, 7-1, C-4, H-6, H-25
Wet Bed .....	7-2, B-26, B-34, B-36
Width .	1-3, 3-1, 6-7-9, 8-1, 8-5, 8-6, 9-1, 9-5, 10-1-4, B-7-9, B-11, B-34, D-4, D-10, D-11, D-15, D-16, E-28, E-29, E-32, E-35, E-39, E-43, E-48, E-51, G-4, H-7, H-14, H-23
Bottom ..	2-8, 9-1, 9-5, B-2, B-7, B-9, B-12, B-14, B-15, B-17, B-23, B-38-45, E-49, E-50, E-52, E-53, F-2, H-4, H-29, H-30
Top ..	2-8, 8-5, 8-6, 9-5, 10-1, 10-3, 10-5, 10-6, 11-5, B-7, B-11, B-15, B-22, B-26, D-11, D-16, E-27, E-29, E-30, E-33, G-4, H-20
WIL .....	B-38
Write .....	1-1, 6-6, 10-1, B-16, H-2, H-8, H-14, H-28-31, H-35
WS .....	1-2, 4-3, 7-6, 10-3, 10-4, B-1, B-38, D-12, H-14
WSP .....	B-38, D-3, D-11
W-Record .....	G-12, G-13
X-coordinates	
X-Record .....	11-8, 11-9, G-13
XSEC .....	11-5
coordinate .....	11-5, B-20, B-30, E-19, E-27, E-37, E-38, E-41, E-44-46, E-52, F-27, F-28
X-coordinates .....	11-2
YITMP .....	8-4
YMAX .....	8-5, 8-6
Zone .....	11-4, B-8, H-2

